

2091721_C - SG5000U Installation Manual_072022

EN **Instructions for Fitting, Operating and Maintenance**
Speed Guardian SG4000U

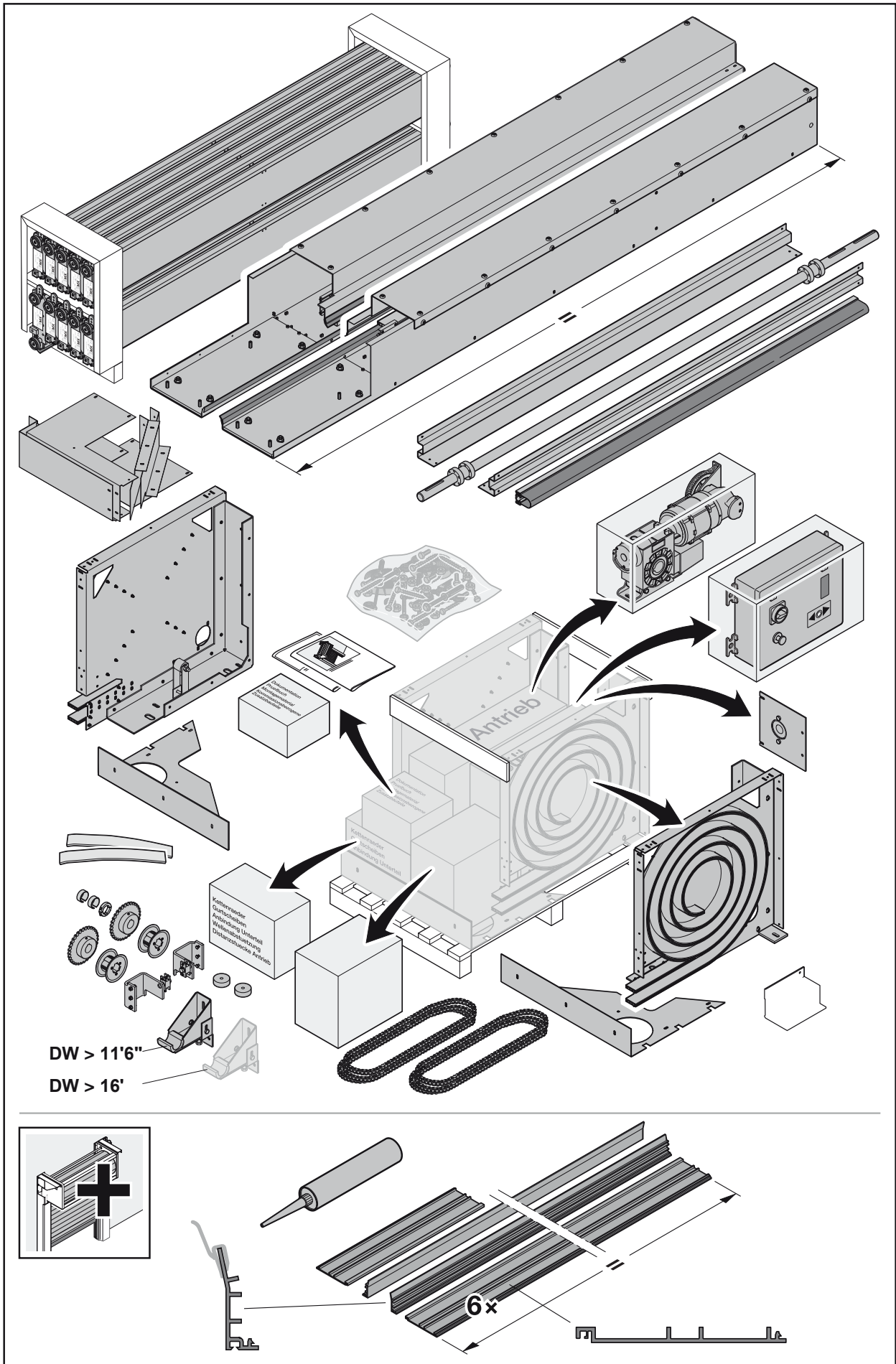

Contents

A Used Symbols 3

B Used Abbreviations 4

1 To the Owner 4

1.1 Receiving and Handling 4

1.2 Introduction 4

2 Safety 4

2.1 Intended Use 4

2.2 Organizational Measures 4

2.3 Selection and Qualification of Personnel 5

2.4 Safety-Related Remarks
for Specific Operating Phases 5

2.5 Remarks About Possible Types of Hazard 5

3 Installing 5

3.1 Before Starting Installation 5

3.2 Door Opening Preparations 6

3.3 Control System and Control Elements 6

4 Initial Operation 6

4.1 Instructions for Initial Operation 6

4.2 Setting the End-Of-Travel Positions 6

4.3 Mounting the Warning Signs 6

4.4 Test Run 7

5 Operating the Door 7

5.1 Instructions On Operating the Door 7

5.2 Emergency-OFF 7

5.3 Cleaning and Care 7

5.4 Conversions 7

6 Inspection and Maintenance of the Door 7

6.1 Inspection and Maintenance 7

6.2 Maintenance 7

6.3 Troubleshooting 8

6.4 Inspection and Maintenance Plan 8

7 Control system 8













8 Spare Parts 36

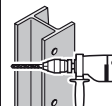

..... 9

Dissemination as well as duplication of this document and the use and communication of its content are prohibited unless explicitly permitted. Noncompliance will result in damage compensation obligations. All rights reserved in the event of patent, utility model or design model registration.

A Used Symbols

	Important advice to prevent injury to persons or damage to property
	Warning of dangerous electrical voltage
	Tighten the screws firmly
	Do Not Overtighten
	Optional components
	Drilling in steel
	Drilling in concrete
	Remove residue
	Inspect
	Danger of crushing
	Risk of shearing
	Risk of impact
	Risk of trapping during door travel
	Grease



Thread lock



Correct arrangement or activity



Non-permissible arrangement or activity



Remove and dispose of component or packaging

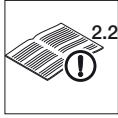

See text section

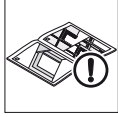

See illustrated section



See separate Fitting Instructions for the control or for the additional electrical control elements

B Used Abbreviations

OFF	Top edge of finished floor line
DW	Door Width
DH	Door Height

1 To the Owner

This manual describes installation, operation, care and maintenance procedures for the Speed-Guardian™ High Speed Roll-Up door. Please keep this manual in a suitable place for reference.

1.1 Receiving and Handling

Check to see that the number of packages matches with that shown on the Bill of Lading when receiving shipment of Speed-Guardian™ High Speed Roll-Up door. Any damage to the crate or packaging material should be noted on the shipping receipt. Exterior damage may indicate interior damage. Uncrate and check the unit for shipping damage, missing parts and, if necessary, prepare freight claims against the freight carrier for any damage discovered.

1.2 Introduction

The Operating Instructions provide important information representing prerequisites for working safely with and on the industrial door.

Please carefully work your way through the Operating Instructions before putting the industrial door into operation. Thoroughly acquaint yourself not only with the „Safety“

chapter but also with the posted information signs and their meanings. You must know the arrangements and functions of all the control elements before you start up the installation for the first time.

When carrying out any work, always pay attention to the information in the Operating and Maintenance Instructions.

Furthermore, the existing regulations on accident prevention and environmental protection as well as the recognized specialist technical rules for safe and competent working must be observed.

Competent operation and careful maintenance have a considerable bearing on the performance and availability of your industrial door. Operating errors and inadequate maintenance lead to avoidable operational malfunctions. Satisfactory, permanent operational reliability and safety is only guaranteed provided the door system is expertly operated and carefully maintained.

The **“Operation“** chapter includes all the information required for operating the door correctly. It is assumed that the operator already has special knowledge about the industrial door and its possible uses. Our installers provide instruction after the door system has been put into operation.

In the **“Maintenance“** chapter, all the maintenance work and checks are listed and described to such an extent that any mechanic familiar with maintaining machines can perform the work competently. The maintenance instructions do not represent instructions to allow more large scale repairs to be carried out. Contact your Hörmann Flexon dealer for these kinds of repairs.

The manufacturer is not liable for any damage caused as a result of non-compliance with the Operating Instructions and the information contained therein or due to non-customary use.

2 Safety

2.1 Intended Use

Industrial doors are used to close openings for through-traffic, to safely close rooms, to make machines safe and secure, to save energy costs, to improve the room air conditions and to accelerate the flow of materials. Any other or further use is regarded as non-intended use.

The manufacturer/supplier is not liable for any damage resulting from this. The risk is borne solely by the user. The intended use also includes paying attention to the Operating Instructions and observing inspection and maintenance conditions.

2.2 Organizational Measures

Complying with Laws and Regulations

In addition to the Operating Instructions, generally applicable statutory regulations and other binding regulations for accident prevention and environmental protection must be complied with and corresponding instructions must be given in respect of these. This also applies to national regulations which must be observed locally.

Keeping the Operating Instructions Ready at Hand

Always have the Operating Instructions available at the location where the industrial door is used.

No Conversion Work

Without the supplier’s approval, do not carry out any modification, attachment or conversion work on the industrial door which might compromise safety!

No Program Modifications

Do not make any program modifications (software) on programmable control systems!

Fire Extinguishers

The location and operation of fire extinguishers must be indicated by appropriate information signs! Pay attention to the statutory fire-alarm and fire-fighting regulations.

2.3 Selection and Qualification of Personnel

Instructed Personnel

Appoint only qualified and trained personnel. Responsibilities regarding operation, maintenance and repair must be clearly stipulated to ensure maximum safety!

 ATTENTION
Electrical Work only by a Specialist Work on the electrical components may only be carried out by electrical specialists and only in the de-energized state (main switch at OFF and main cable disconnected) in accordance with the electrical regulations.

2.4 Safety-Related Remarks for Specific Operating Phases

 ATTENTION
Operational Shutdown during Work on the Industrial Door All the work on the industrial door (such as maintenance and cleaning work as well as inspections) may only be performed during an operational shutdown.

Normal Operation

 ATTENTION
Avoiding Danger When operating the door care should be taken so not to cause injury or damage to personnel and vehicles.

 ATTENTION
„REMOVE PROTECTIVE FILM FROM ALL INSULATED PANELS IMMEDIATELY AFTER INSTALLATION, NOT DOING SO WILL VOID WARRANTY“

Only Work When Protective Safety Devices are Present

Take measures to ensure that the industrial door is only operated when it is safe and in proper working order!

Only operate the industrial door when all the protective devices and safety-related devices (e.g. detachable protective devices) and emergency-OFF devices are present and functioning!

Safety devices must not be modified, dismantled or put out of operation.

Maintenance Work and Eliminating Malfunctions

Complying With Inspection Intervals

The adjustment, maintenance and inspection work and intervals stipulated in the Operating Instructions (including information about the replacement of parts/partial equipment) must be complied with! These activities may only be carried out by qualified personnel.

Original Spare Parts

Spare parts must fulfill the technical requirements stipulated by the manufacturer. This is always guaranteed when original spare parts are used.

2.5 Remarks About Possible Types of Hazard

Gas, Dust, Steam and Smoke Excluding the Risk of Fire and Explosion

Only carry out welding, burning and grinding work on the industrial door provided this work has been expressly approved. There may be a risk of fire and explosion!

Cleaning and Ventilating Beforehand

Prior to welding, burning and grinding, remove dust and combustible materials from the industrial door and its surroundings and ensure that there is adequate ventilation to avoid risk of explosion!

3 Installing

3.1 Before Starting Installation

- Take precautionary measures to make the site safe
- Check the on-site installation conditions and check measurements
- Check the quality of the mounting structure for its strength
- Choose suitable fasteners
- Unpack the door and check for damage

REPORT DAMAGE IMMEDIATELY

- Dispose of the packaging material
- Check that the delivery is complete (See page 2)

3.2 Door Opening Preparations

The doorway opening should be square and plumb in order to achieve the best possible installation. Also, the area around the door opening must be free of pipes, electrical conduit, or other obstructions.

There should be enough wall strength to prevent unwanted movement of the door's framework during the opening and closing cycles. In some cases, it may be necessary to structurally reinforce the doorway in order to support the weight of the door. The installer must make this determination. If there are any questions concerning reinforcement of the doorway, the installer should contact the factory.

A solid flush, concrete wall which is free of obstacles, will allow the best and easiest installation.

The floor between the door jambs should also be level. If not, this condition must be compensated for when positioning the guide tracks.

Check the size of the Speed-Guardian™ against the size of the door opening before beginning the actual installation.

IMPORTANT: The size (width x height) is written on a tag attached to one of the guide tracks. There is also a tag on the gearbox which shows the size.

If necessary, the door may be installed in an opening that is slightly narrower or wider than the door's finished size. However, the tolerance should be no more than 1 inch.

If the opening is 1 inch smaller, the guide tracks may be positioned 1/2 inch out from the jamb to compensate. Positioning the guide tracks back on the jamb at a distance more than 1/2 inch may prevent the breakaway feature on the door from operating effectively in case of accidental impact.

If the doorway is wider by more than 1" the width (W) of the Speed-Guardian™ door supplied, DO NOT install the door. Contact Hörmann Flexon at (800) 365-3667.

3.3 Control System and Control Elements

⚠ ATTENTION
<p>Only carry out the electrical installation if you are a qualified electrician or have been adequately instructed by a qualified electrician, and are able to meet the following requirements:</p> <ul style="list-style-type: none"> ▶ You recognize the hazards that electricity involves. ▶ You are acquainted with the applicable regulations concerning electricity. ▶ You can use and take care of safety equipment. ▶ You know how to administer first aid. <p>Make sure that the electrical installation complies with the applicable safety requirements.</p> <p>Do not apply any external voltage to the connecting terminals of the control unit. This will completely destroy the electronics.</p> <p>Never pull on the connecting leads of the electrical components. This will completely destroy the electronics.</p> <p>Consult the Hörmann Flexon technical support department before making any changes to any of the electrical components. Any unauthorized modifications to the control box or any electrical components of the door will void the warranty.</p> <p>Install the control unit within sight of the door.</p>

Follow any further instructions supplied which provide information on

- Making the electrical connections
- Installing additional electrical control elements

4 Initial Operation

4.1 Instructions for Initial Operation

⚠ ATTENTION
<p>Before initial operation of the door and making it operational, check that it is in good working order and free of defects.</p>

4.2 Setting the End-Of-Travel Positions

The end-of-travel positions of the door, are set on the control cabinet. Please pay attention to the instructions for the operator and control (see chapter 7 also).

Set the end-of-travel positions as follows:

CLOSE end-of-travel position

- The bottom profile makes full contact with the floor

OPEN end-of-travel position

- Clearance ~ 3/4" (8.2) to the seal profile lower edge

⚠ ATTENTION
<p>If the door travels beyond the OPEN end-of-travel position, there is a risk of the door curtain slipping out of the side guides and sustaining damage.</p>

4.3 Mounting the Warning Signs

Each Speed-Guardian™ High-Speed Roll-Up door comes with two warning signs as shown below.

Make sure that one sign is mounted on each side of the wall on which the door is mounted.

IMPORTANT: The size (width x height) is written on a tag attached to one of the guide tracks. There is also a tag on the gearbox which shows the size.



For obvious safety reasons, both signs must be displayed as described above.

4.4 Test Run

After installing the door, test the functional safety according to the product report. Place on record in the inspection book, dated and signed, that a test run has been successfully completed. Also make note of this information on the front cover of this manual.

ATTENTION

After installing, testing and inspecting the door, hand the entire door documentation to the owner or operator of the door.

5 Operating the Door

5.1 Instructions On Operating the Door

As the operator or owner of the door, you are responsible for ensuring that the following regulations (no claim made to completeness) are noted and observed:

ATTENTION

You are responsible for ensuring that only suitably instructed persons operate the door. A person is considered to be authorized, if he/she

- ▶ has received permission from you to use the door
- ▶ has received instruction as to how to operate the door safely.

Wait until the door has come to a complete stop before you walk or drive into the door's area of movement.

Never use the door to lift objects and/or persons.

Whenever driving in or out of the opening, always check that the door curtain has travelled sufficiently far up to provide the necessary passage height.

Only use the emergency operation devices in the event of a power failure or when carrying out repairs.

If used too frequently:

- ▶ there is a risk of damage
- ▶ the warranty is rendered null and void

Protect the door from aggressive and caustic substances, such as:

- ▶ nitrous reactions from stone or concrete
- ▶ cement
- ▶ plaster
- ▶ acids
- ▶ alkali
- ▶ road salt
- ▶ aggressively reacting coatings/paint
- ▶ aggressively reacting sealants

Do not open or close the door if it is windy (not an outside door).

The construction of the high speed door corresponds to the present state of the art design. Pressure marks are a result of the construction and are unavoidable.

Temperatures of over 120 degrees F. are to be avoided as damage can be caused to the curtain.

5.2 Emergency-OFF

Press the red emergency-OFF button in an emergency switch off situation.

5.3 Cleaning and Care

Use warm water together with a neutral, non-abrasive cleaning agent (household detergent, pH value 7). To clean the surface, use only a soft cloth. Rinse off any dirt and dust particles with clear water. Do not rub over the panes when dry, otherwise you risk scratching the surface.

5.4 Conversions

ATTENTION

Any conversion work to the door requires the express permission of the manufacturer. Only use components approved by the manufacturer. Using non-authorized components could overload the door construction which could bring about serious injury.

Carrying out any structural alterations to the door without the manufacturer's permission will render our warranty and product liability null and void.

6 Inspection and Maintenance of the Door

6.1 Inspection and Maintenance

ATTENTION

As the owner or operator of the door, you must have the system inspected and maintained by a specialist at least once a year in the case of more than 20 operations a day, every 6 months. Should you fail to have the door inspected and maintained as prescribed

- ▶ There is a risk of injury.
- ▶ There is a risk of damage.
- ▶ The warranty is rendered null and void.

The high speed door requires low-maintenance.

All bearings, including gearing, are maintenance-free for normal operating conditions and are greased for the working life.

6.2 Maintenance

Depending on the door size and total number of cycles per year, we recommend:

If a total of 50,000 cycles per year is exceeded, service all functional elements every six months:

- Electric operator incl. gearbox safety device and brake.
- All the screw connections.
- Travel limit cut-off.
- Light Curtains.
- Control system/impulse generator.

If the curtain is extremely dirty, cleaning is recommended using a proprietary cleaning agent.

⚠ ATTENTION

Adjustment and maintenance work may only be carried out in the de-energized state.

In general, we recommend entrusting maintenance/testing to your qualified Hörmann Flexon installer.

6.3 Troubleshooting

In general, we recommend entrusting maintenance/inspection to your qualified Hörmann Flexon installer.

Operator's driving power

The operating voltage must be 230 V +/-5% or 460 V / 3 ph / 60 Hz, otherwise there can be problems with the operator power (optional operating voltage 208 V / 3 ph / 60 Hz).

6.4 Inspection and Maintenance Plan

Only inspect and maintain this door if you are qualified to do so, and you have the suitable training, knowledge and practical experience which allows you to carry out inspections and maintenance correctly and safely.

When carrying out inspections and maintenance, observe the applicable regulations on occupational safety.

7 Control system

Locate and mount the Smart Start™ HFC1 control box with the following in mind: The control box should be located four (4) feet from the floor to the bottom of the box. Mount the control box on the motor side of the door. Refer to the Smart Start™ HFC1 Electrical Diagrams and Operation Manual, which is included with this manual, for details about installing the control box, plugging in the plug in connectors and powering the door.

The control system is manufactured individually for each door ordered. Attach the Electrical Diagrams and Operation Manual contained in the plastic folder provided to cable below control box. Keep the Operating and Maintenance Manual in a safe place for future reference.

⚠ ATTENTION

Each control box has its own identification number which must be quoted in the case of queries.

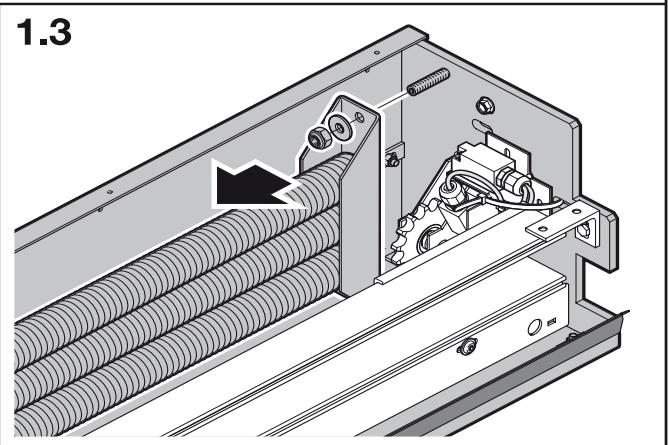
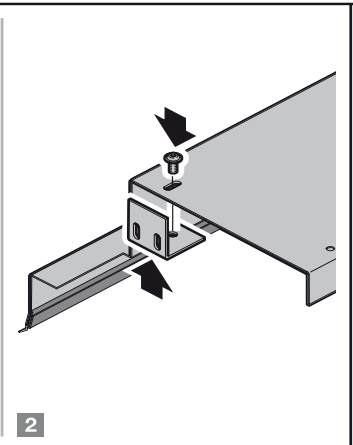
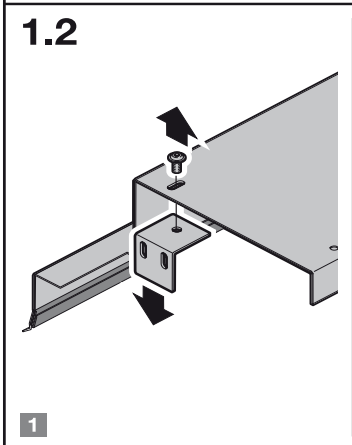
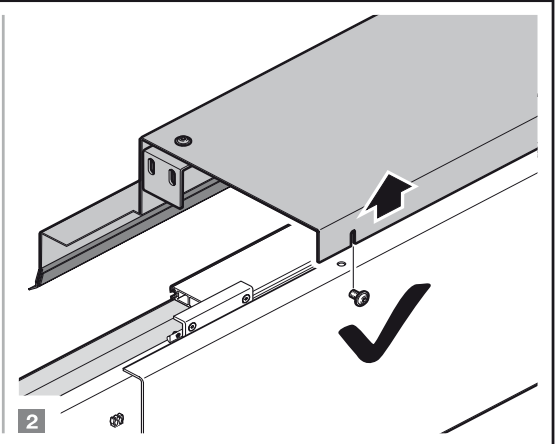
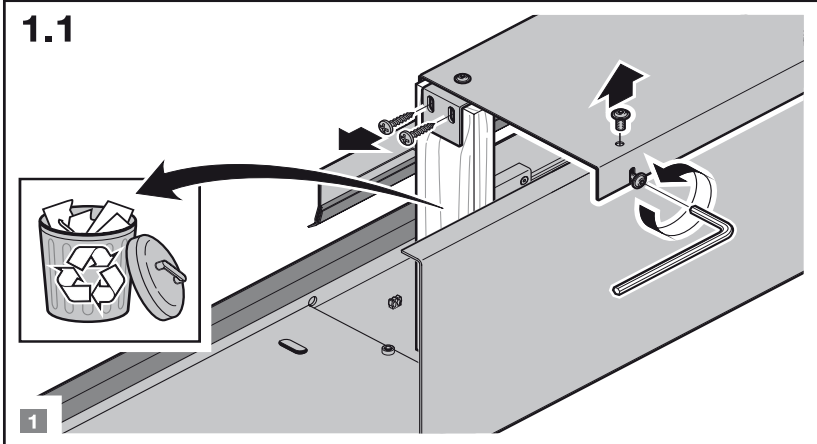
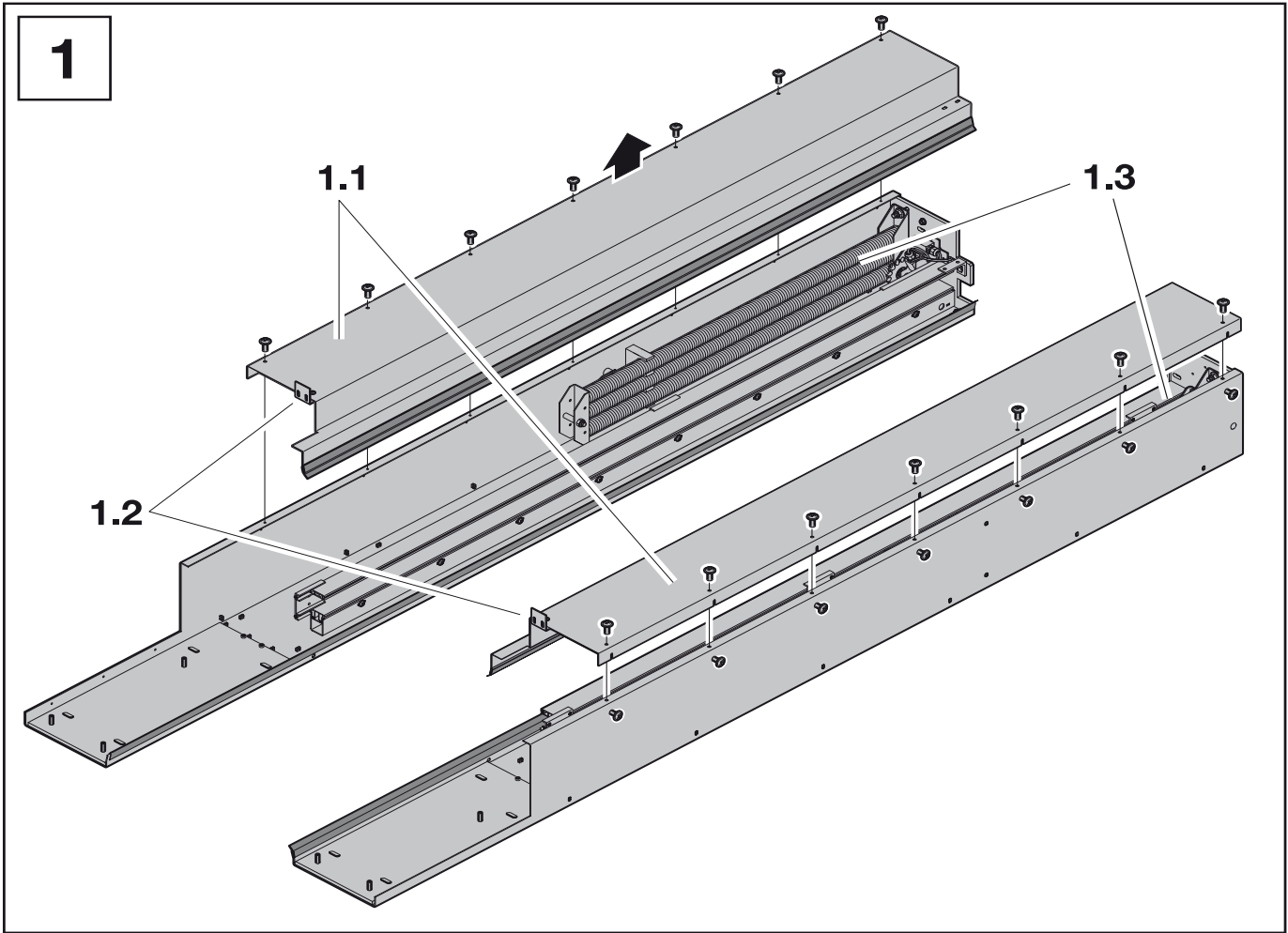

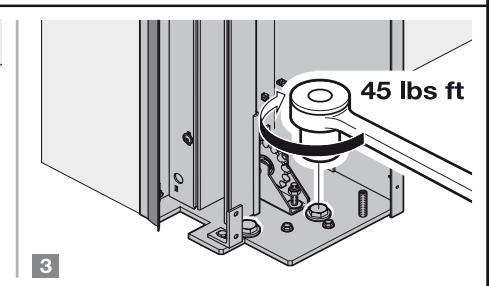
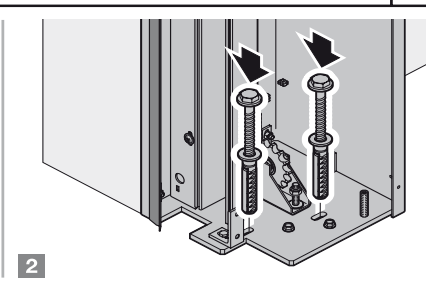
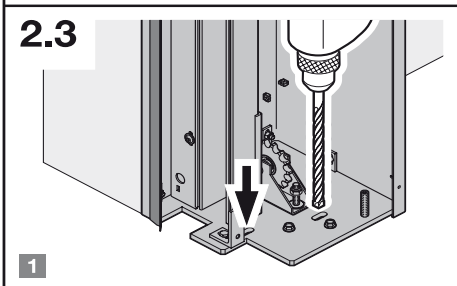
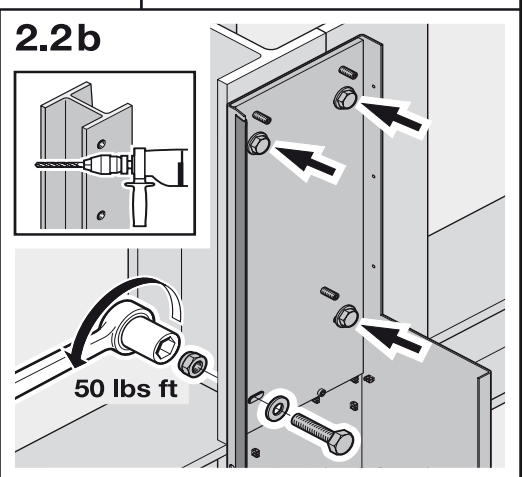
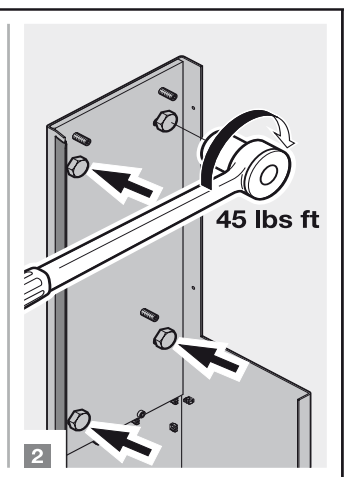
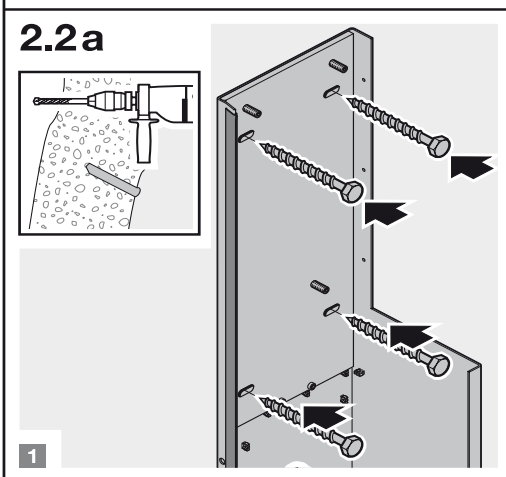
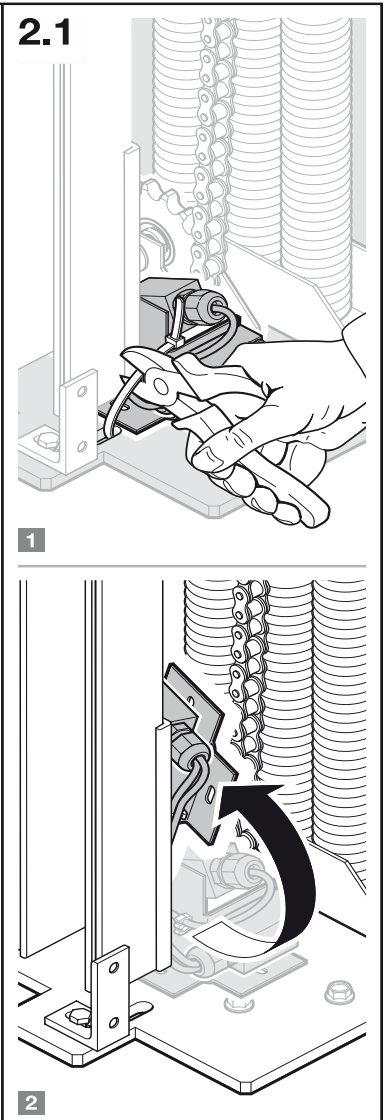
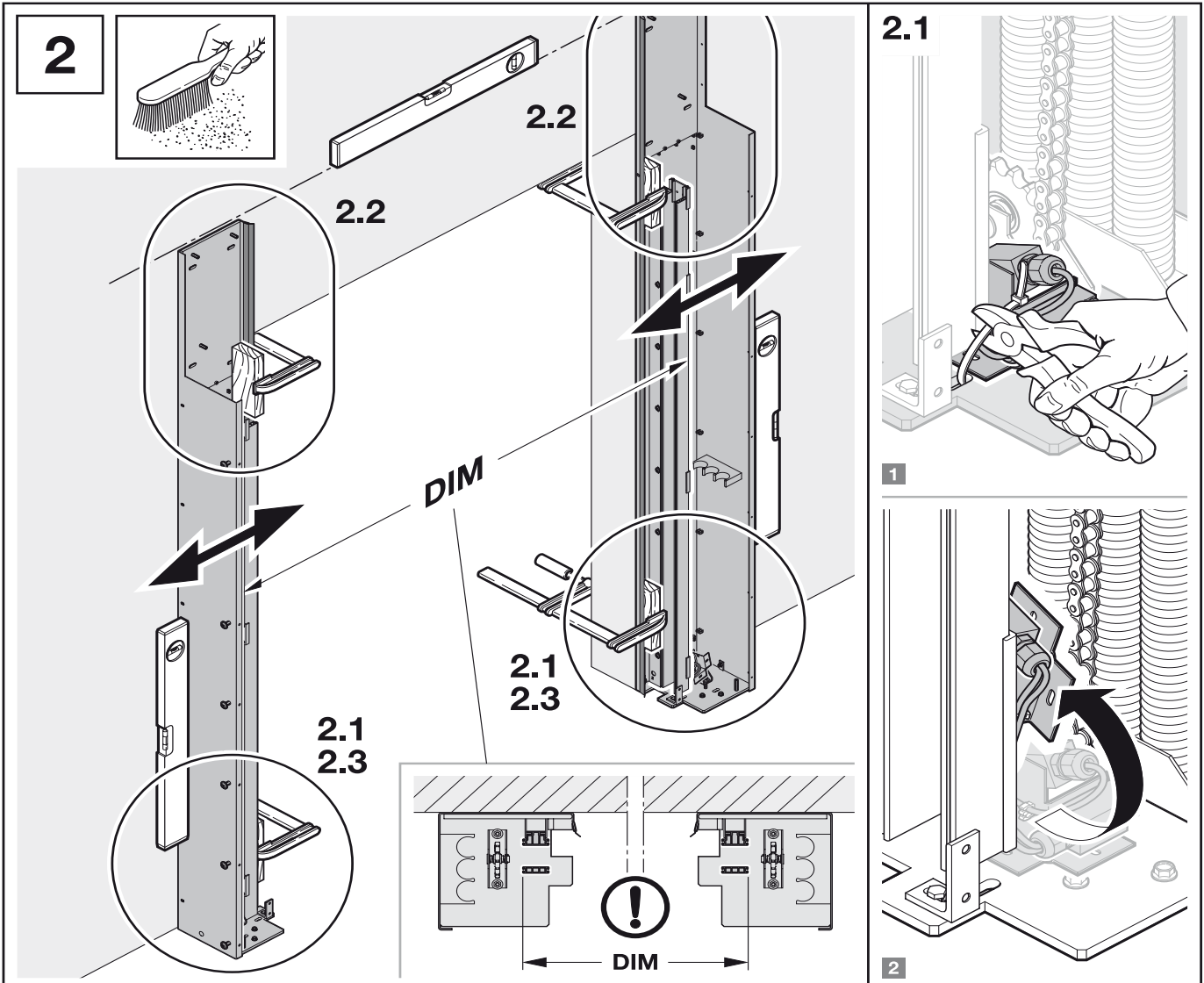

3

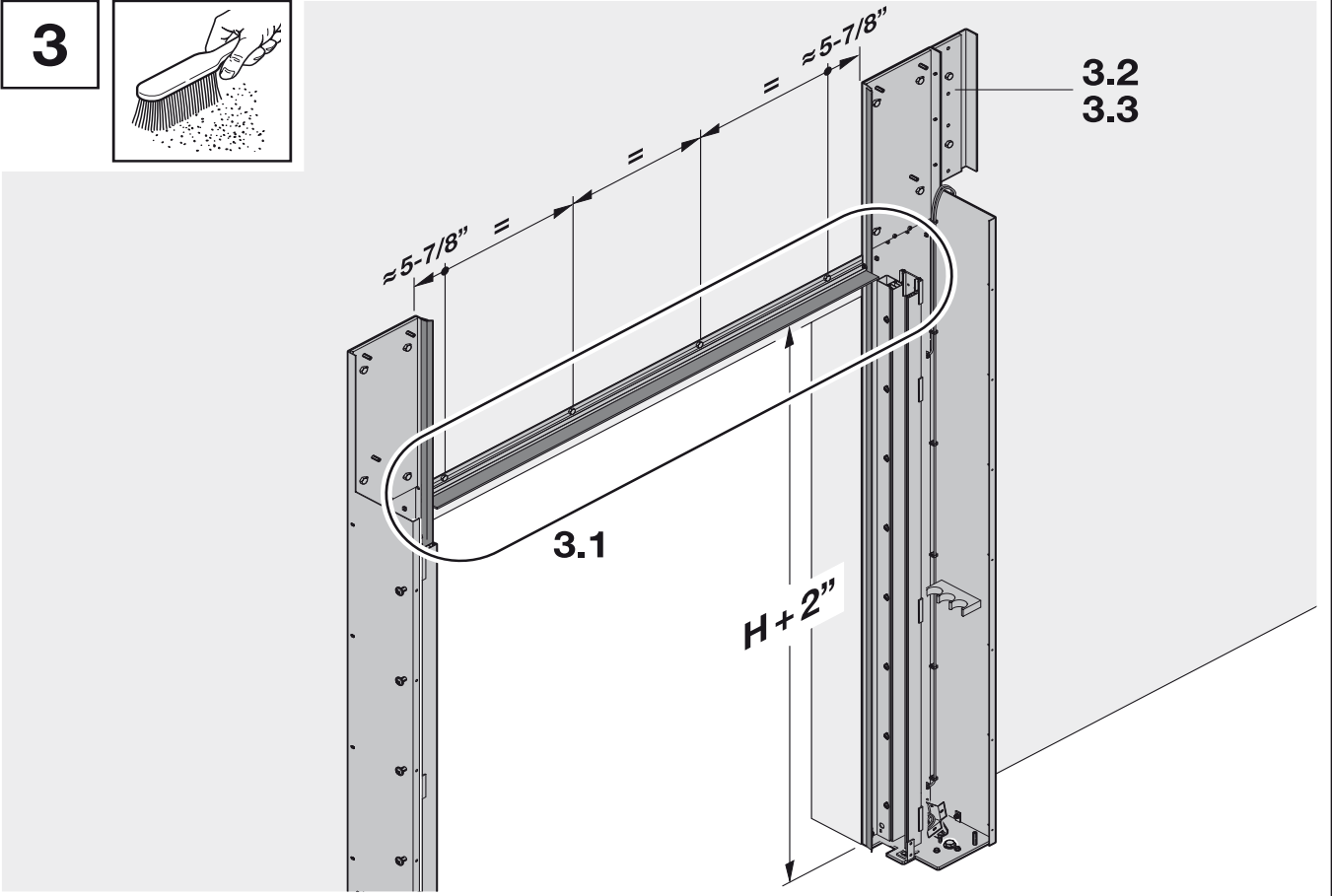

3.1a

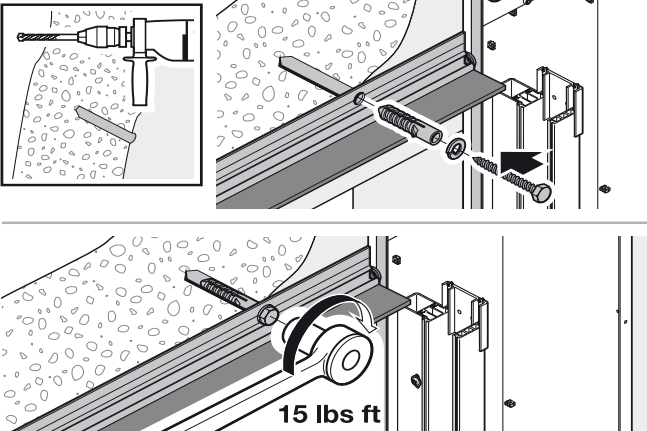

3.1b

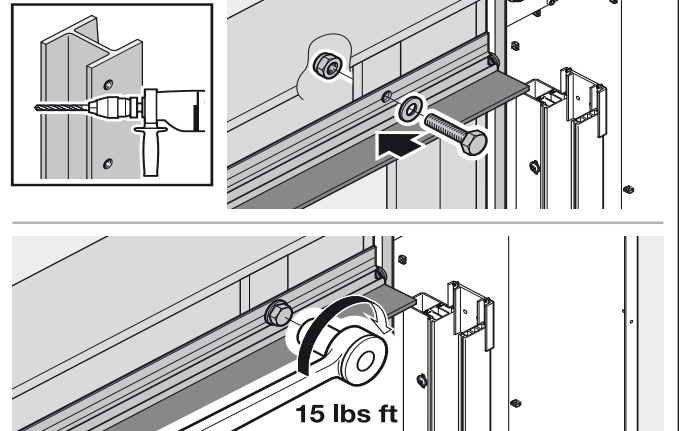

3.2

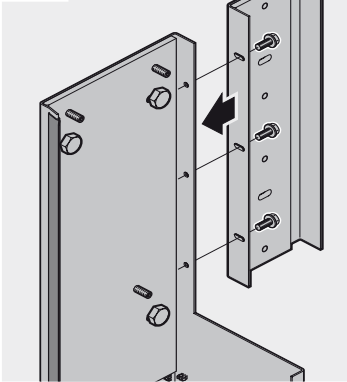

3.3a

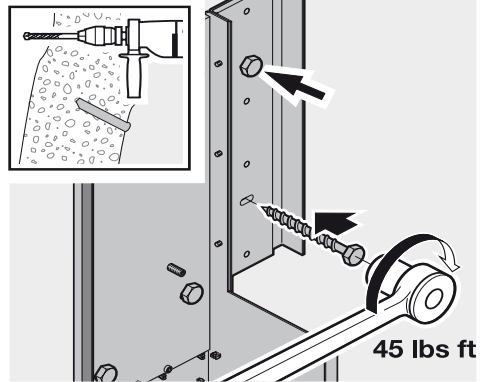

3.3b

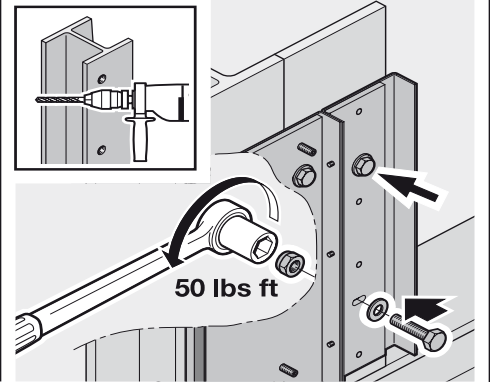

4

4.1
4.2

4.1
4.2

4.1

4.2

1

2

3

4

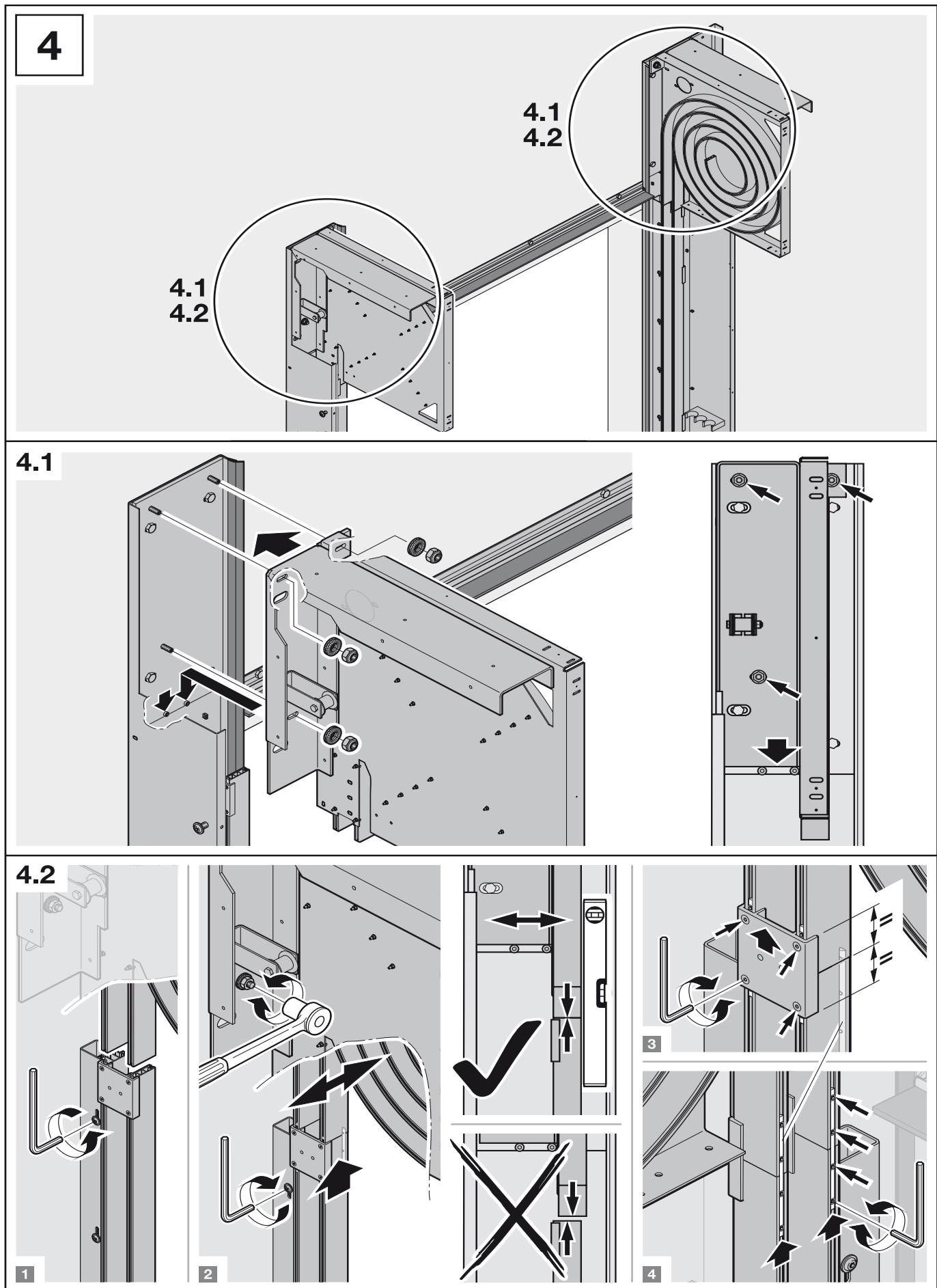

5

5.1
5.2
5.3

5.4

5.1
5.2
5.3

5.1

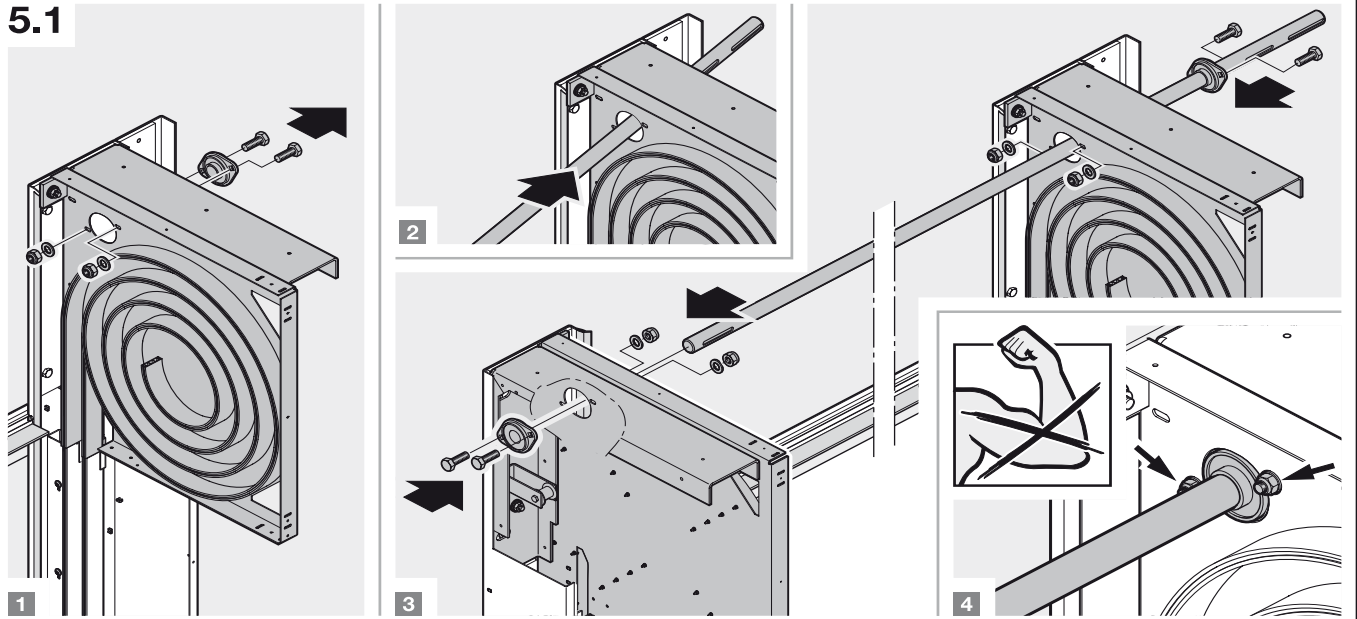

5.2

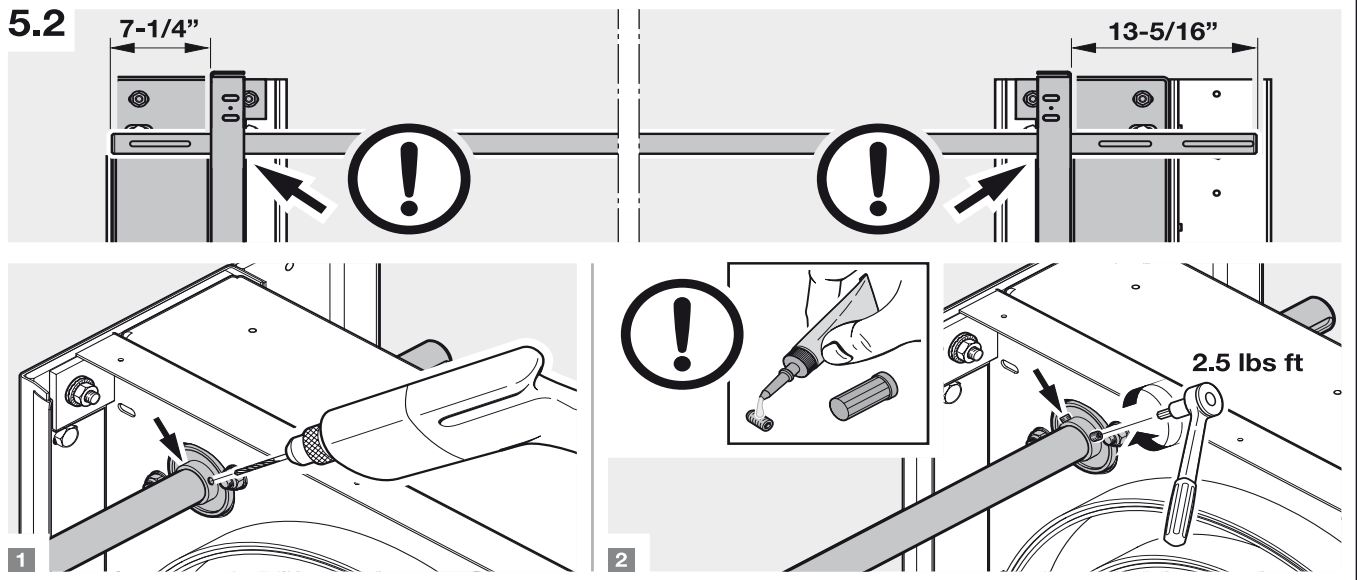

5.3

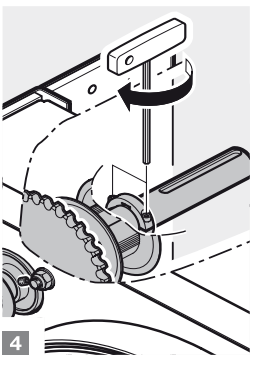
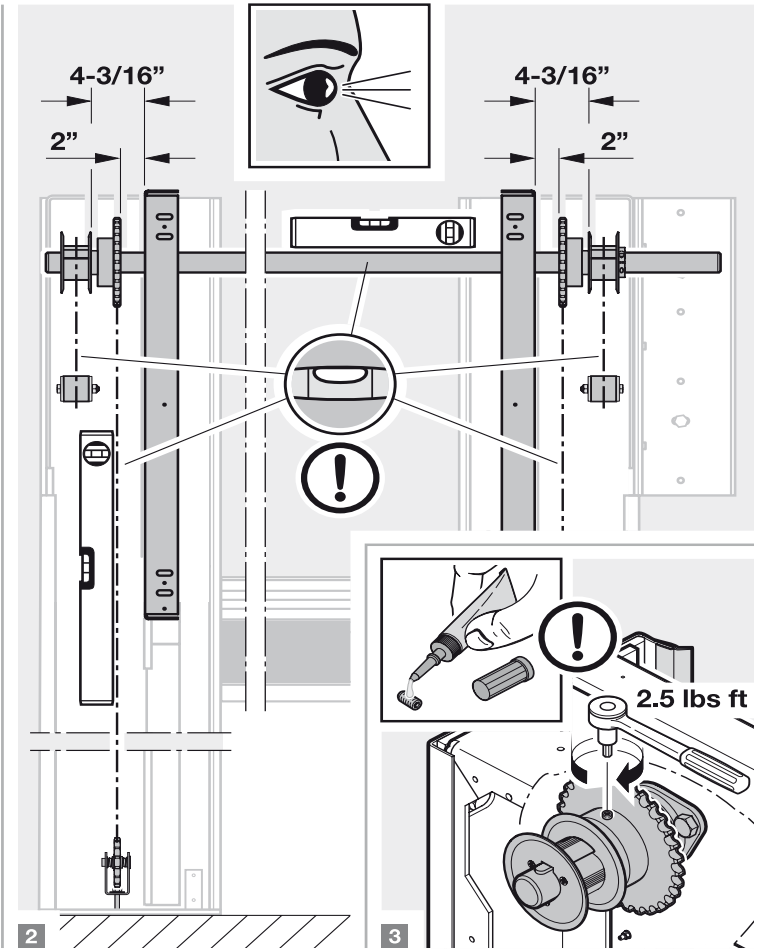
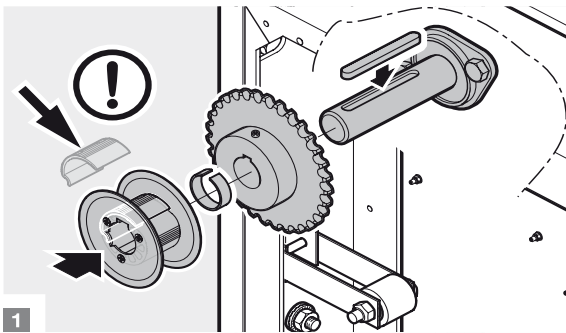
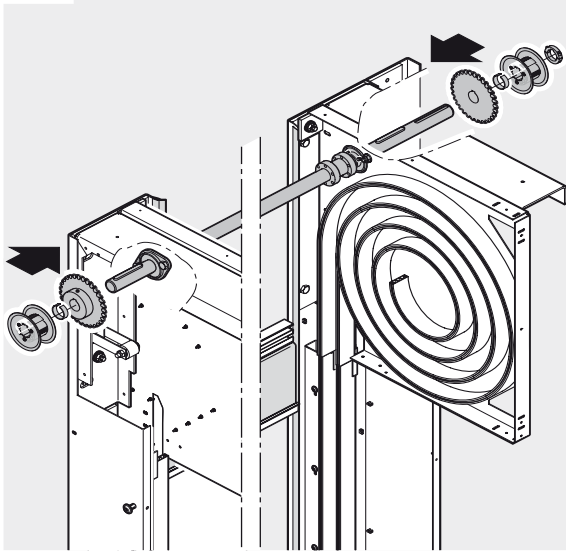

5.4

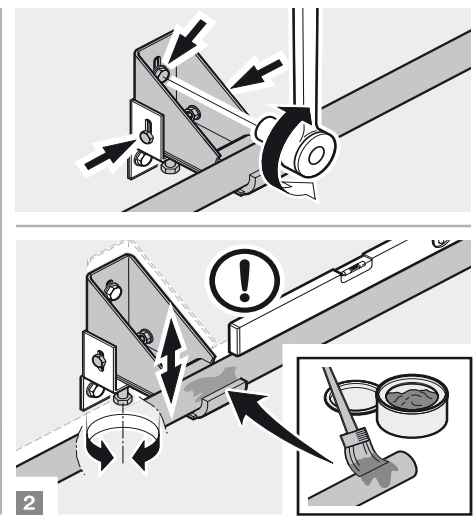
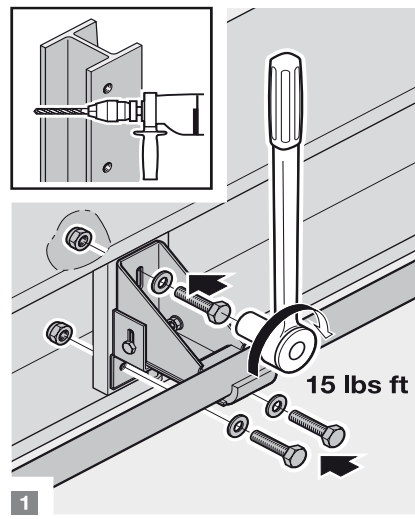
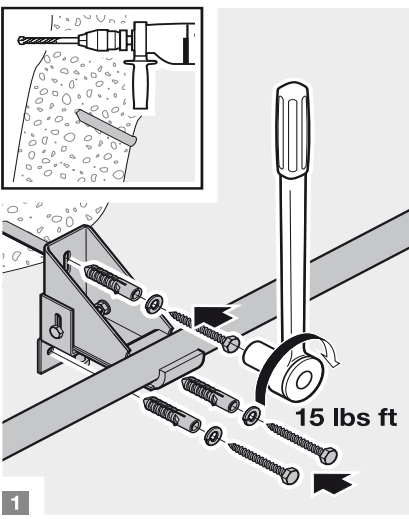
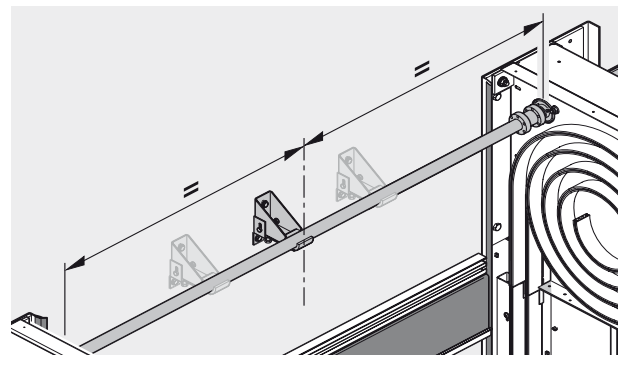
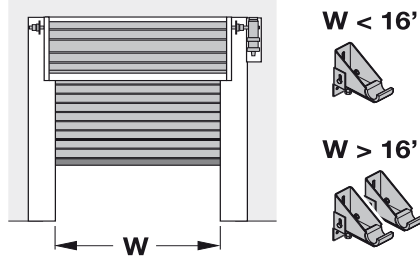

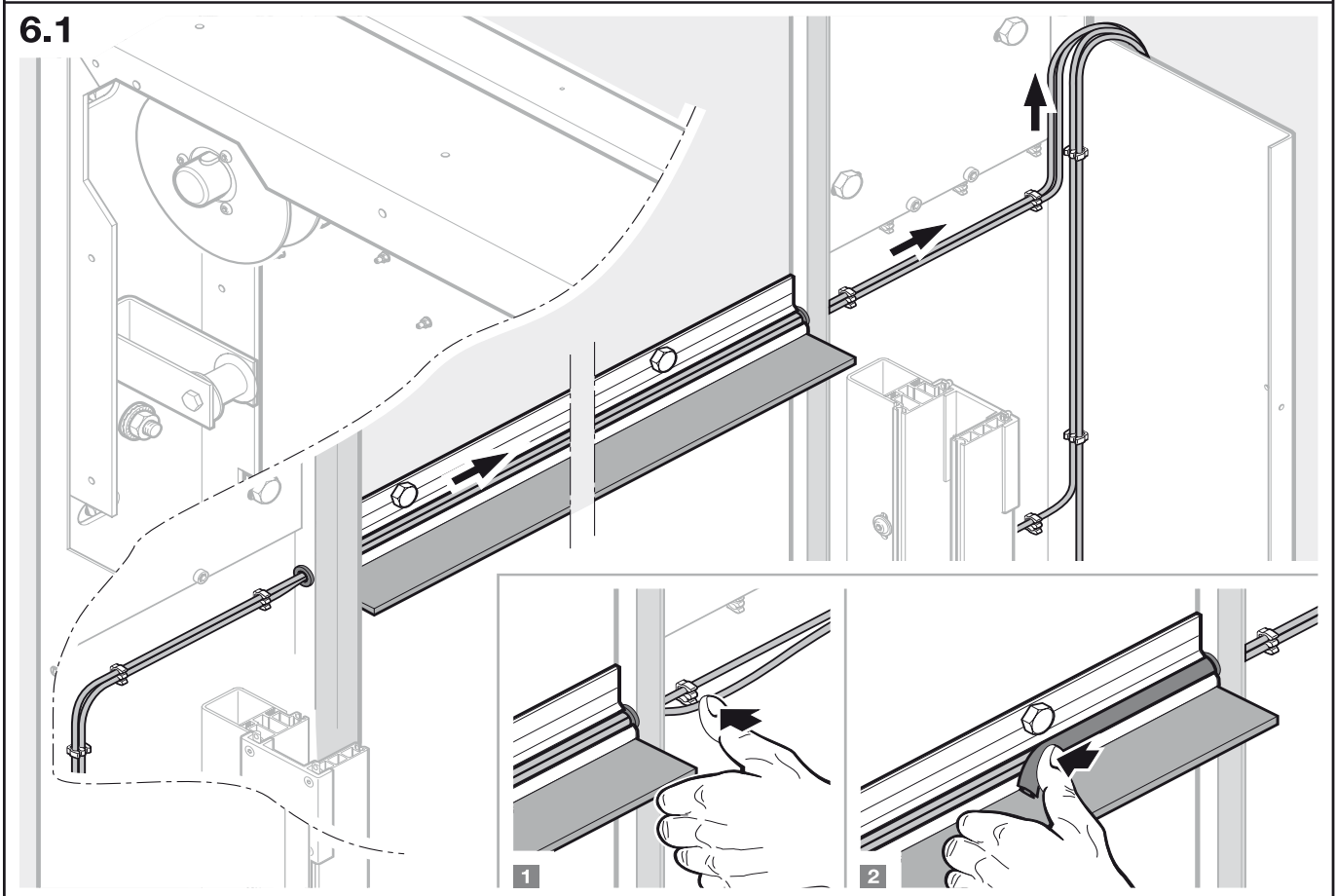
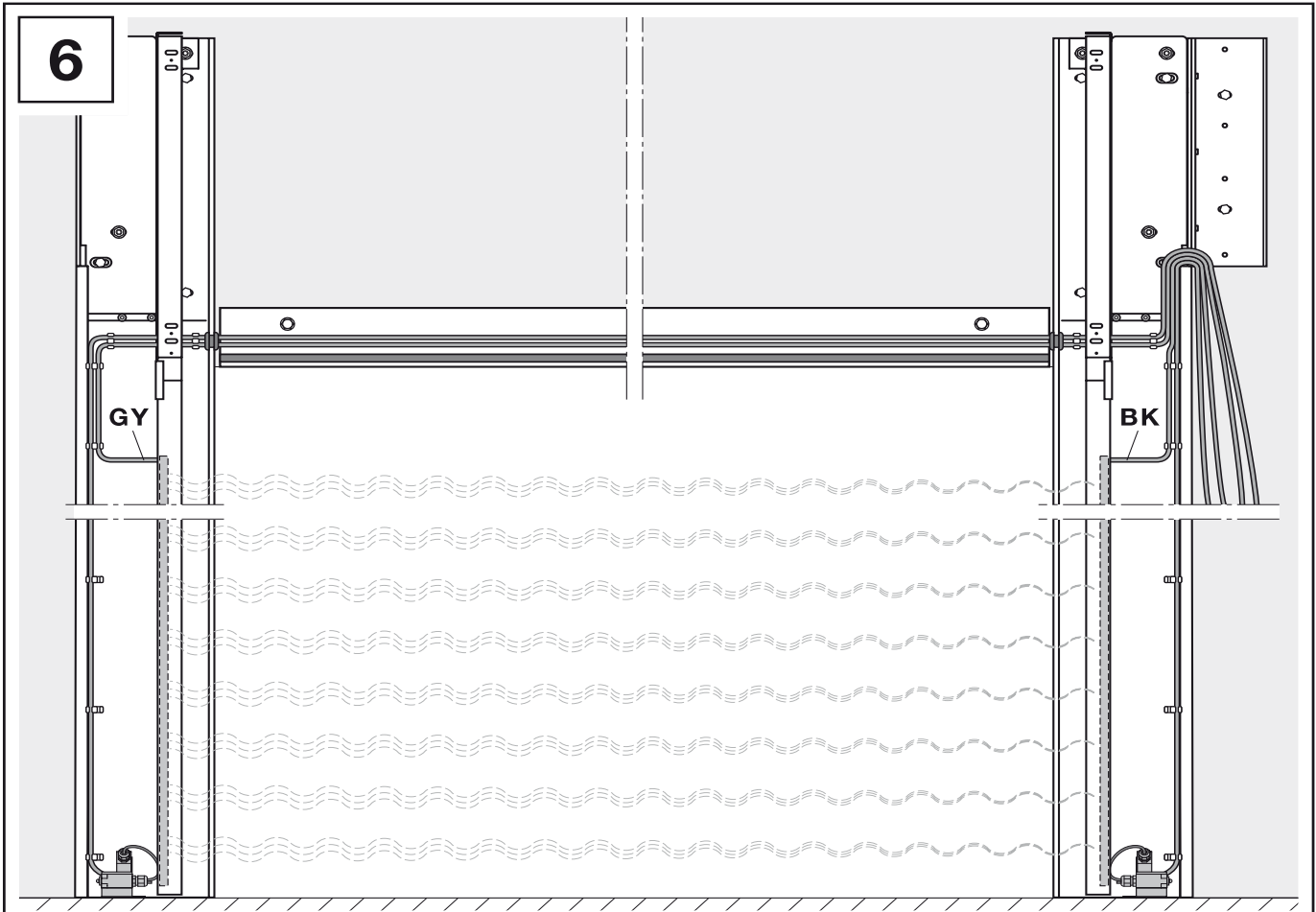

7

7.1
7.3

7.2
7.3

7.4

7.1

7.2

1

2

3

7.3

7.4

1

2

2.5 lbs ft

8

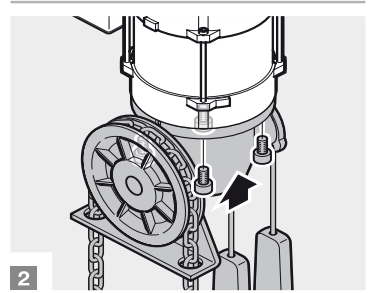
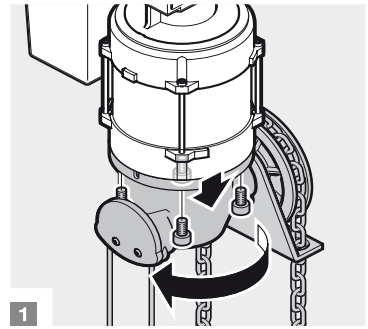
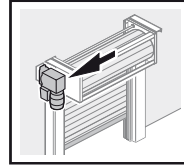
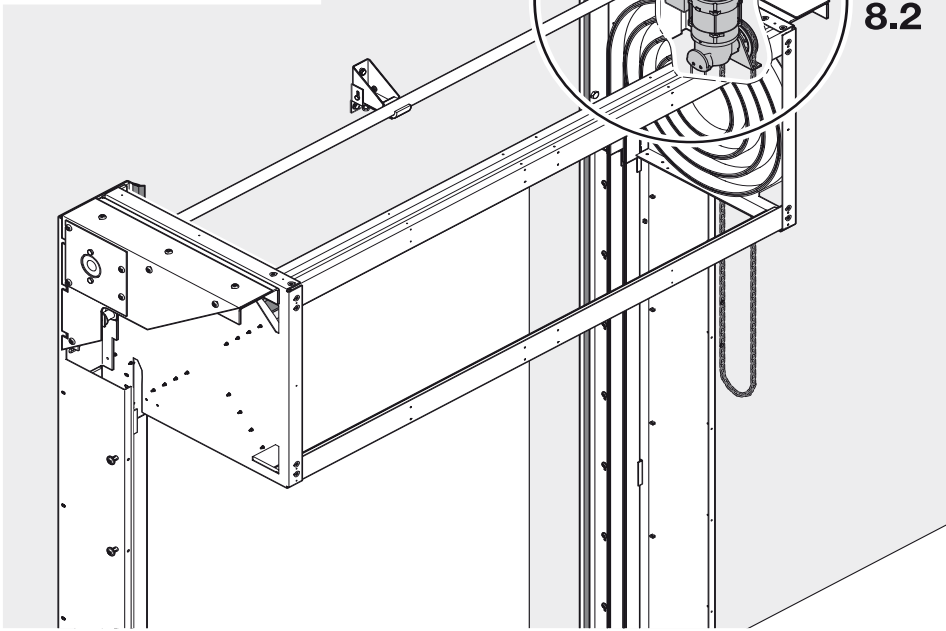
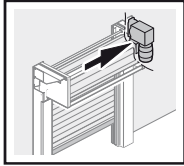

8.1

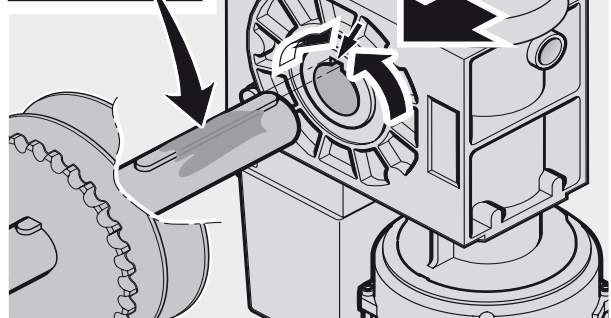
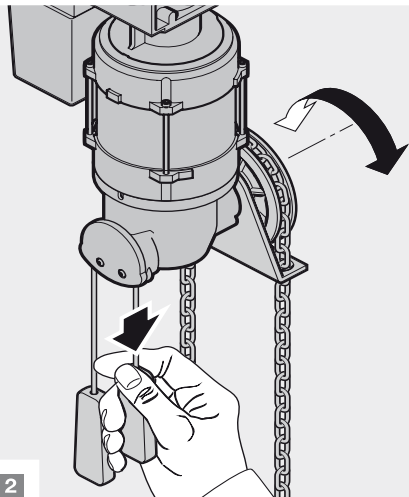
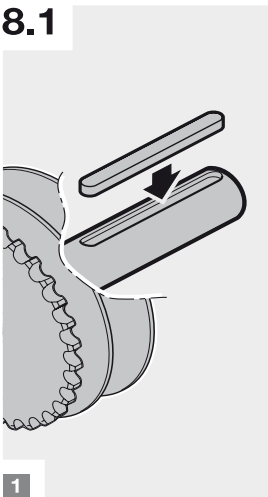

8.2

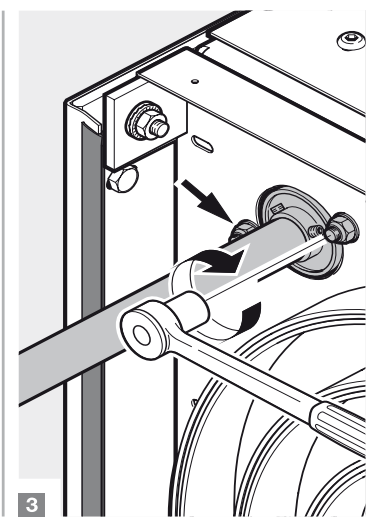
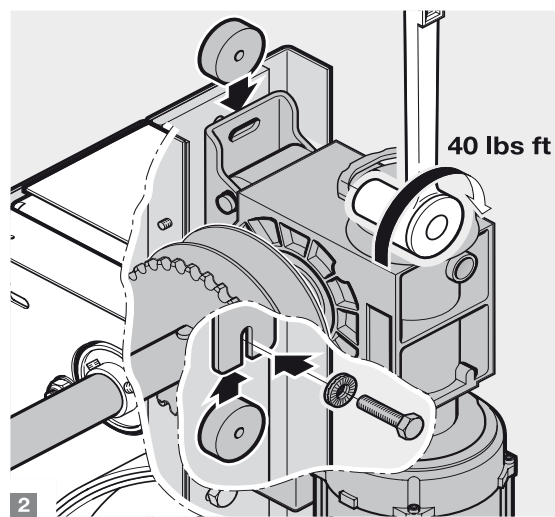
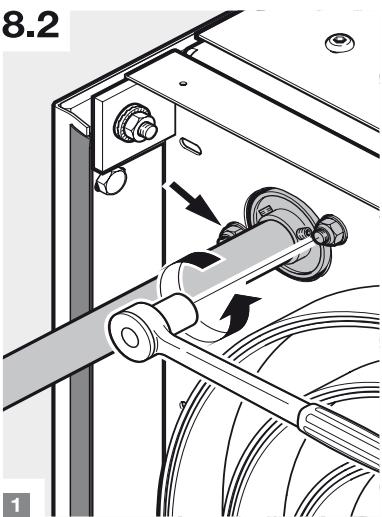

9

9.1
9.2
9.3

9.1
9.2
9.3

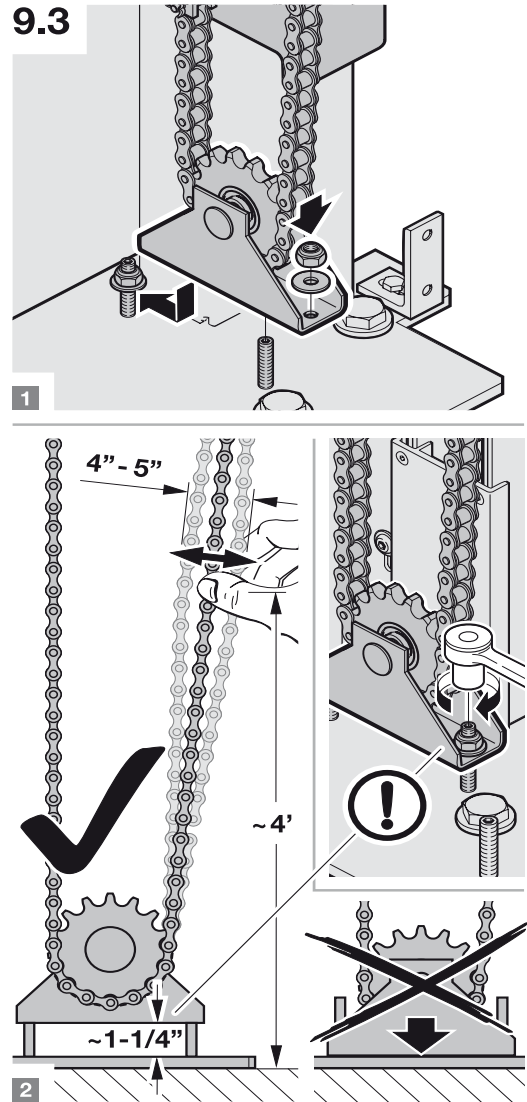
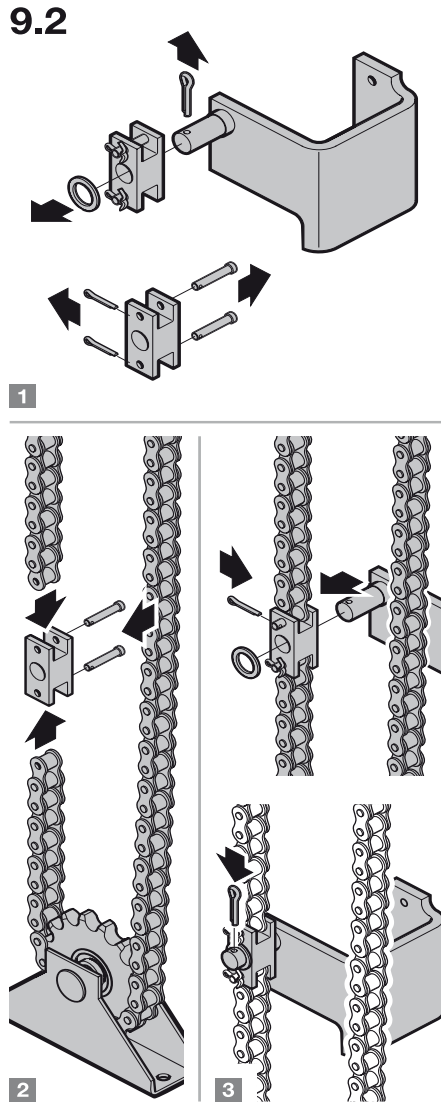
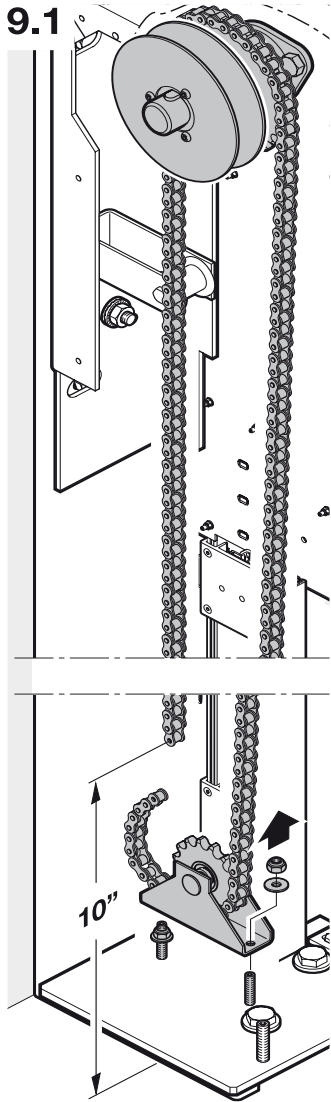

10

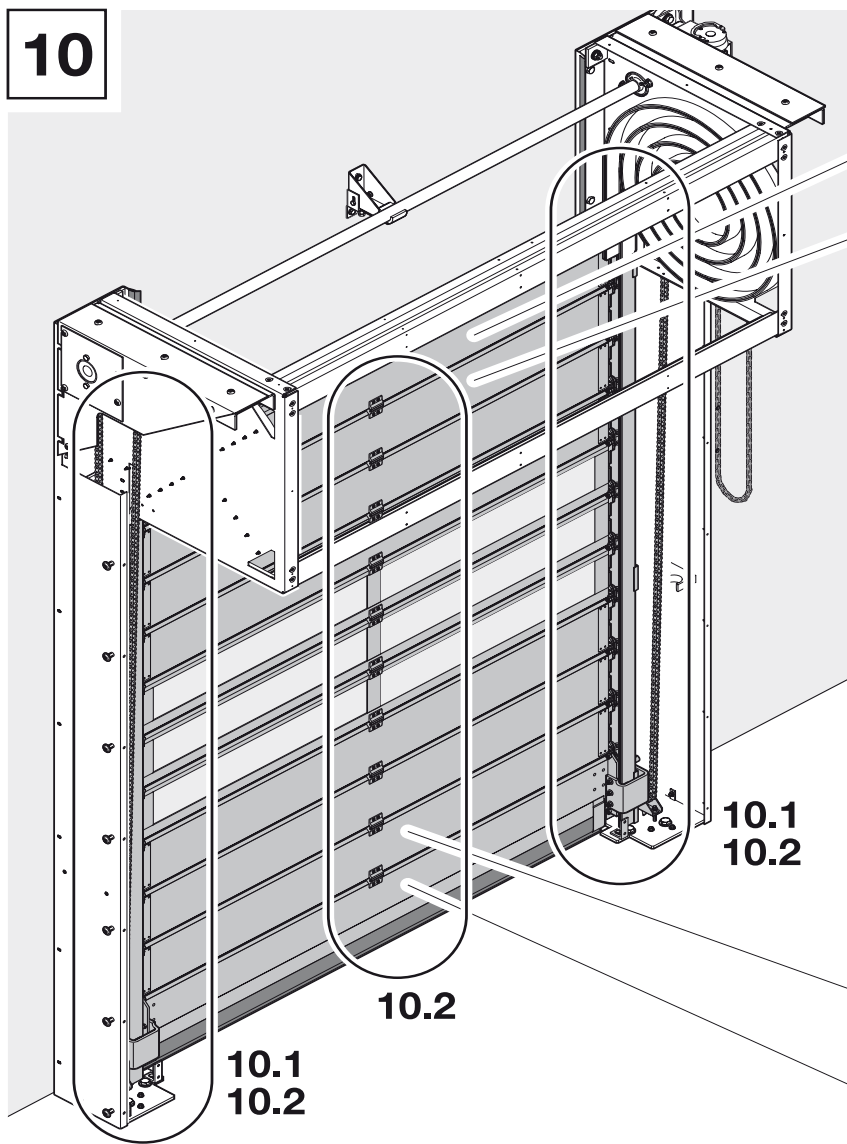

- LB _____ LH _____ SW _____ TorType RTS
KundenRef. _____ RA _____ UNTERP
ProfilTyp _____ SerienProt.
M11 PX
- LB _____ LH _____ SW _____ TorType RTS
KundenRef. _____ RA _____ UNTERP
ProfilTyp _____ SerienProt.
M10 PX
- LB _____ LH _____ SW _____ TorType RTS
KundenRef. _____ RA _____ UNTERP
ProfilTyp _____ SerienProt.
M9 PX
- LB _____ LH _____ SW _____ TorType RTS
KundenRef. _____ RA _____ UNTERP
ProfilTyp _____ SerienProt.
M8 PX
- LB _____ LH _____ SW _____ TorType RTS
KundenRef. _____ RA _____ UNTERP
ProfilTyp _____ SerienProt.
M7 PX
- LB _____ LH _____ SW _____ TorType RTS
KundenRef. _____ RA _____ UNTERP
ProfilTyp _____ SerienProt.
M6 PX
- LB _____ LH _____ SW _____ TorType RTS
KundenRef. _____ RA _____ UNTERP
ProfilTyp _____ SerienProt.
M5 PX
- LB _____ LH _____ SW _____ TorType RTS
KundenRef. _____ RA _____ UNTERP
ProfilTyp _____ SerienProt.
M4 PX
- LB _____ LH _____ SW _____ TorType RTS
KundenRef. _____ RA _____ UNTERP
ProfilTyp _____ SerienProt.
M3 PX
- LB _____ LH _____ SW _____ TorType RTS
KundenRef. _____ RA _____ UNTERP
ProfilTyp _____ SerienProt.
M2 PX
- LB _____ LH _____ SW _____ TorType RTS
KundenRef. _____ RA _____ UNTERP
ProfilTyp _____ SerienProt.
M1 PX

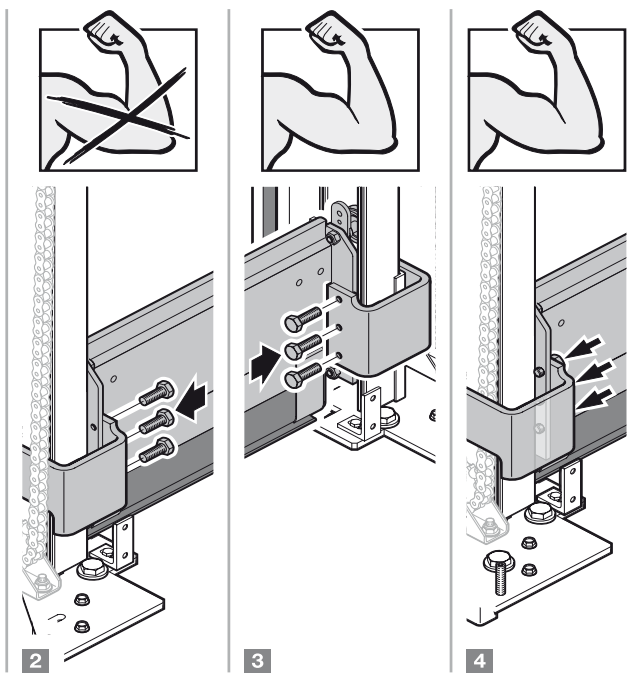
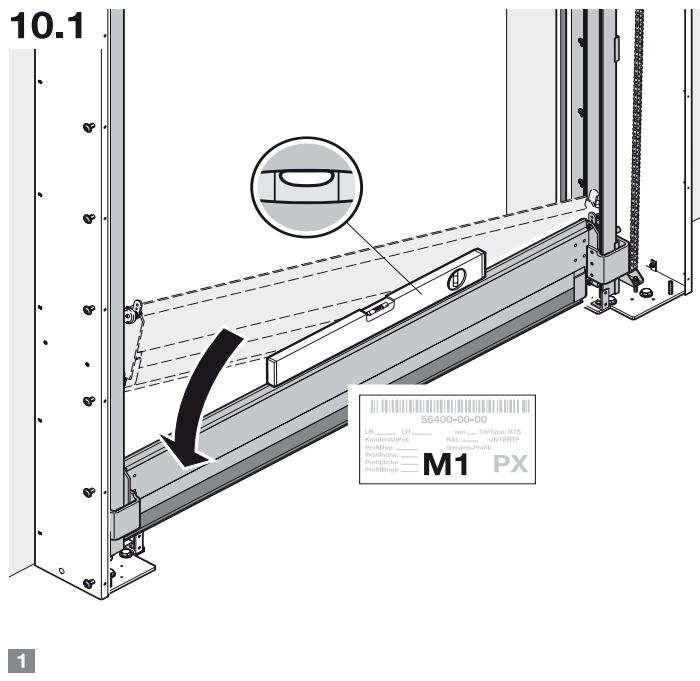
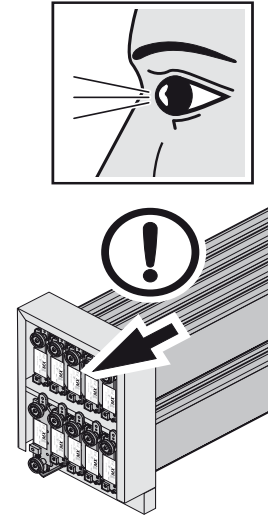

10.2

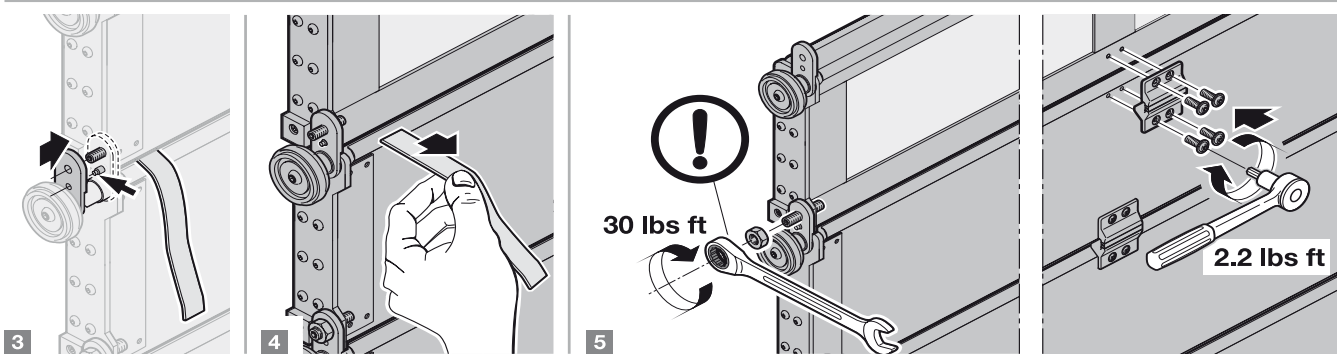
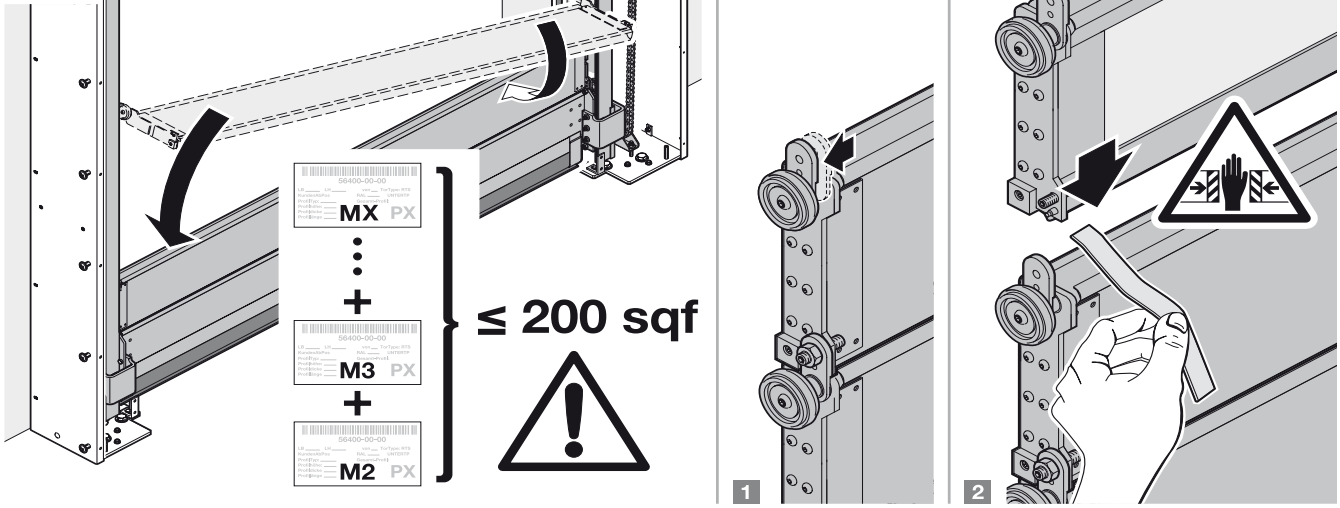

W x H ≤ 250 sqf

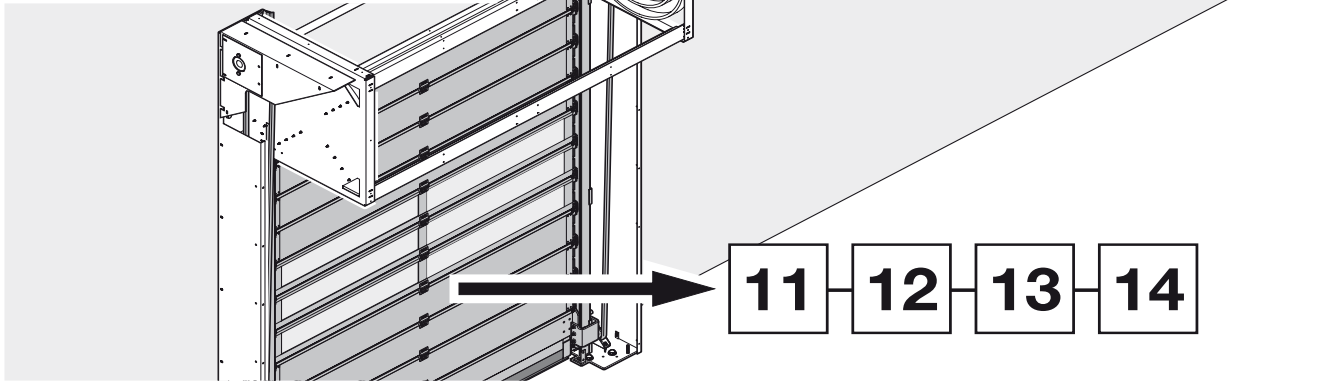

W x H > 250 sqf

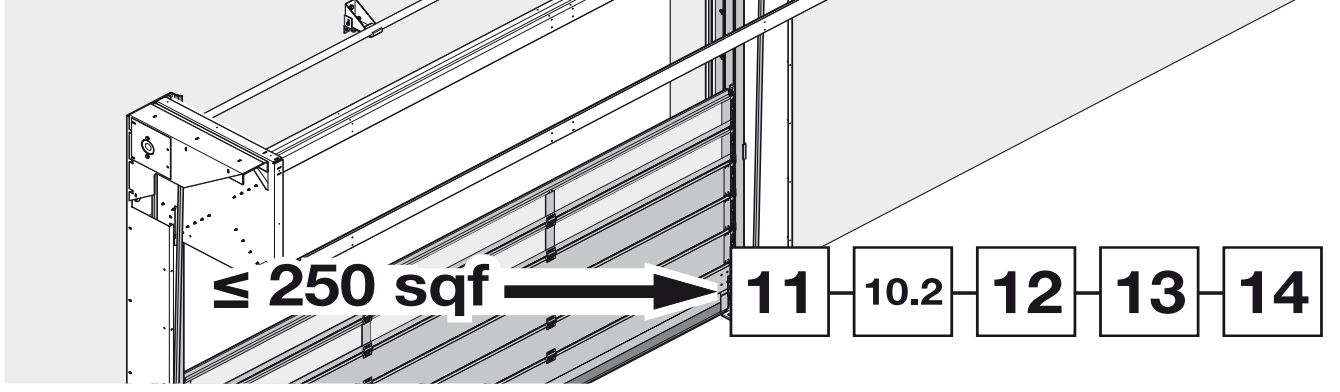

11

11.1

➔

10.2

$M1 + M2 + \dots + MX \leq 250ft^2$

1

3

11.2

11.3

1

2

2

1x

11.4

1

2

3

11.5

$LDH \times LDB > 250ft^2$ ➔

10.2

12

13

14

15

12

12.1
12.2
12.3

12.1
12.2

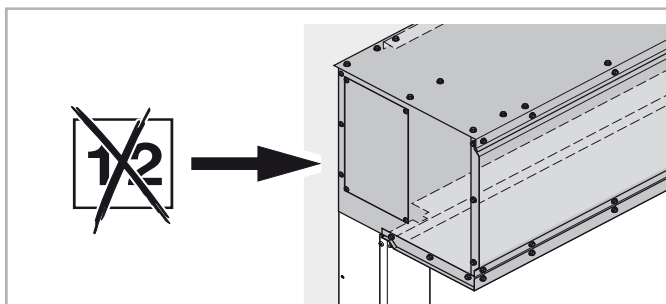

12.1

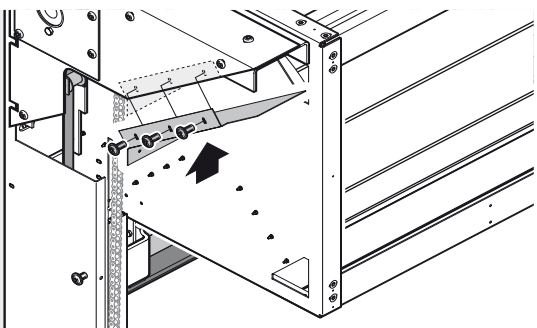

12.2

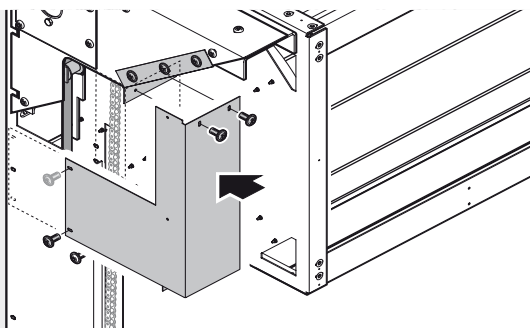

12.3

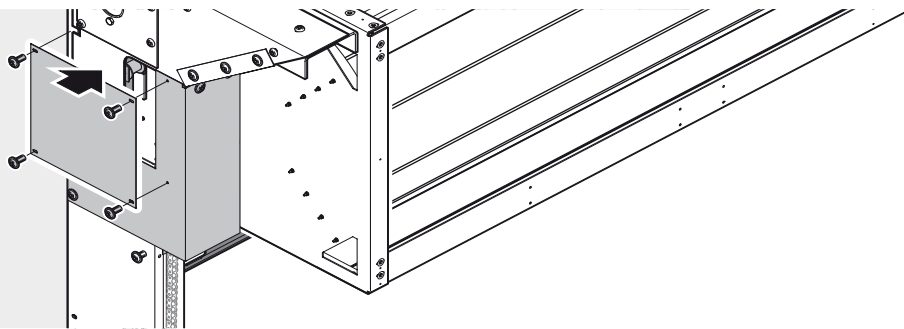

13

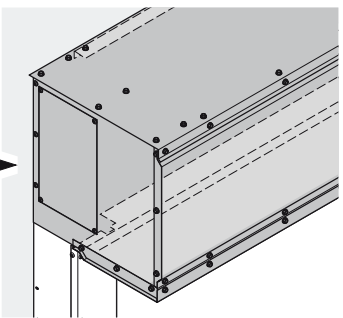
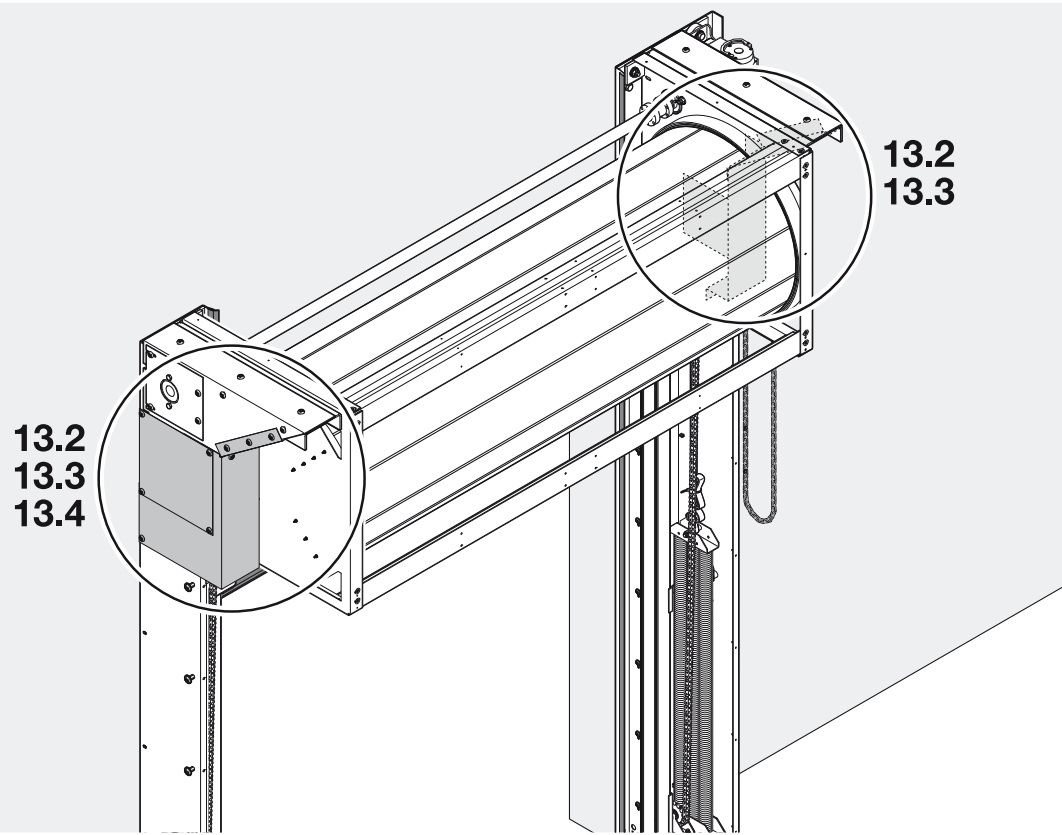

13.1

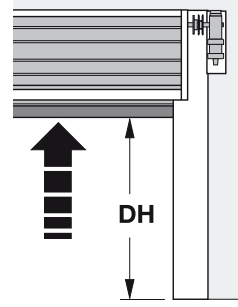
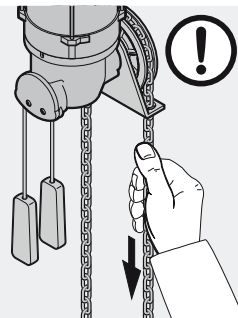

13.2

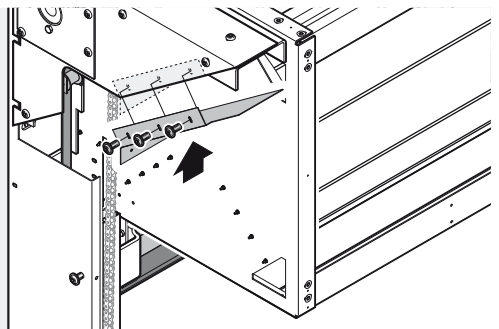

13.3

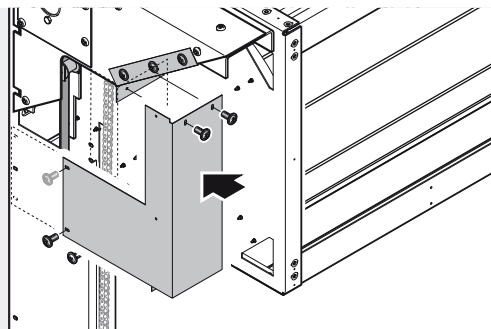

13.4

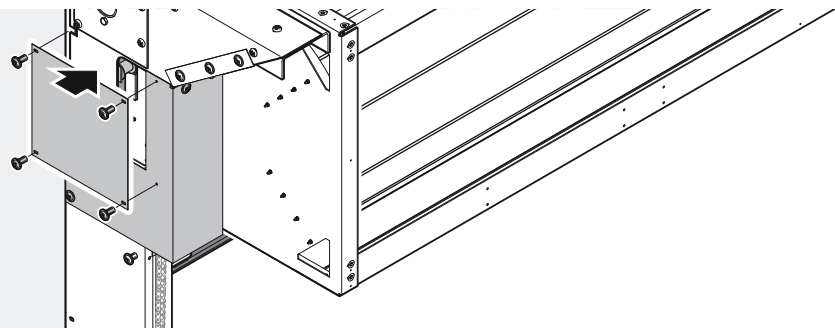

14

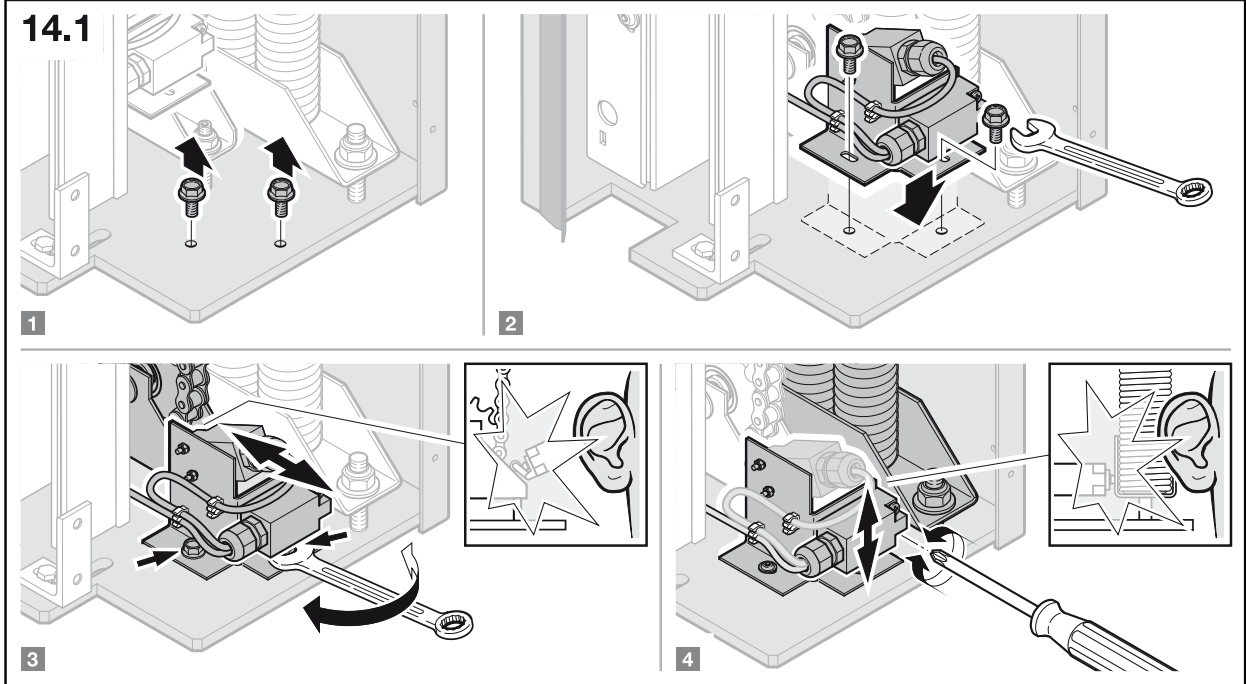
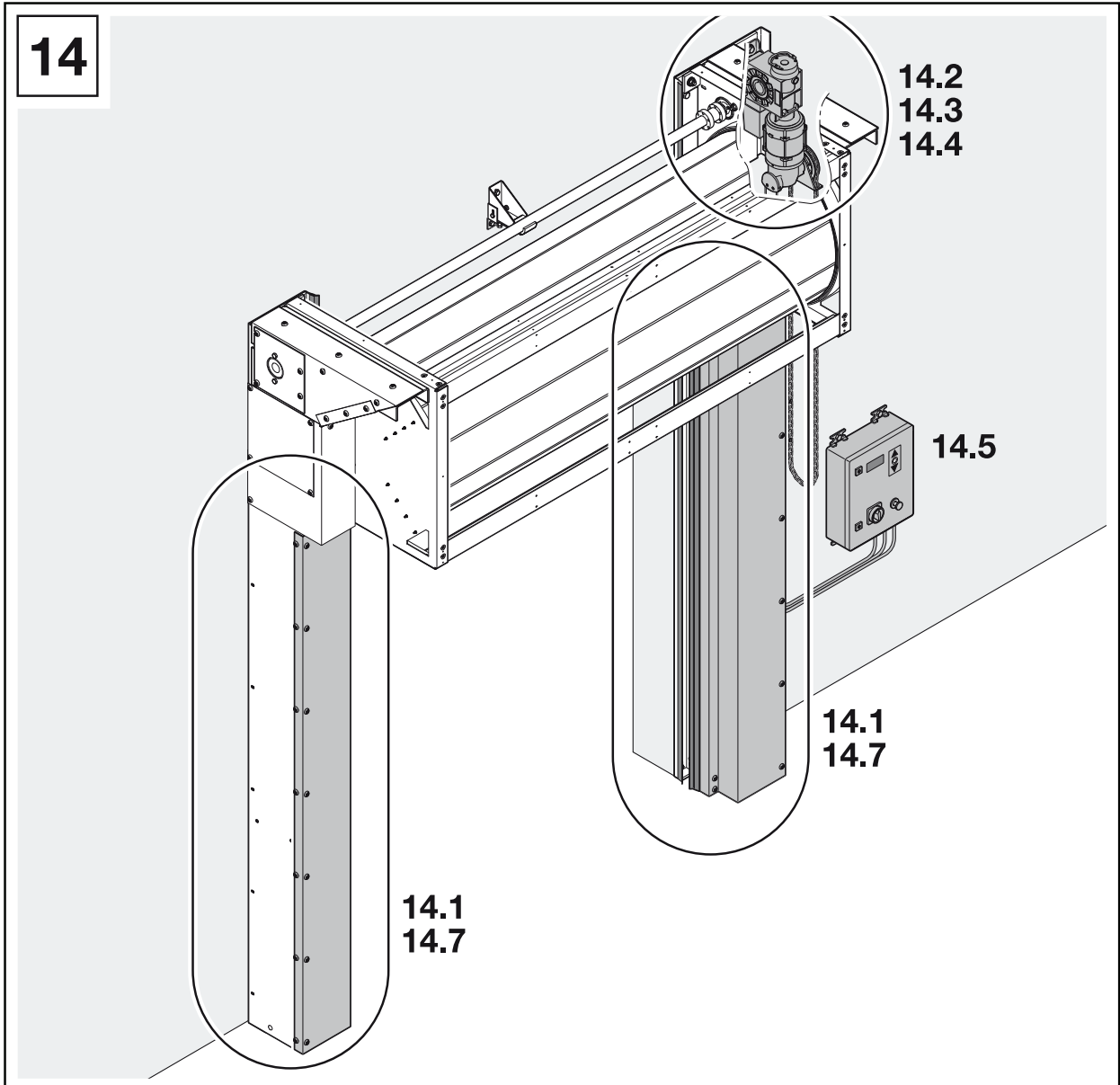

14.2

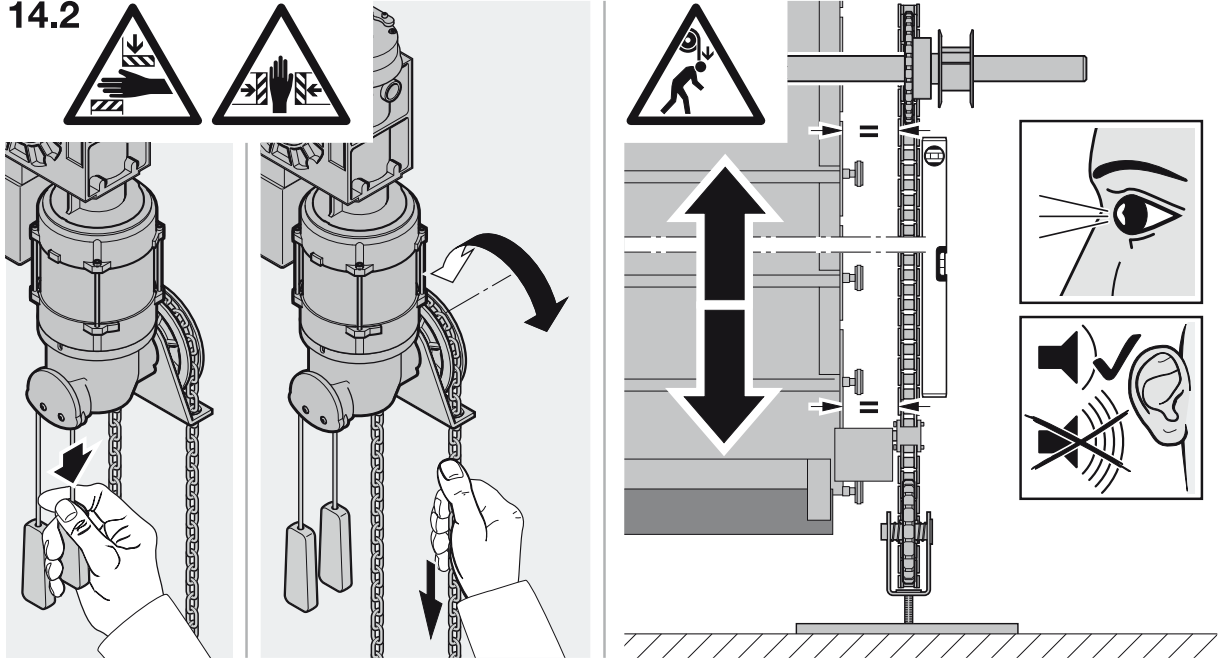

14.3

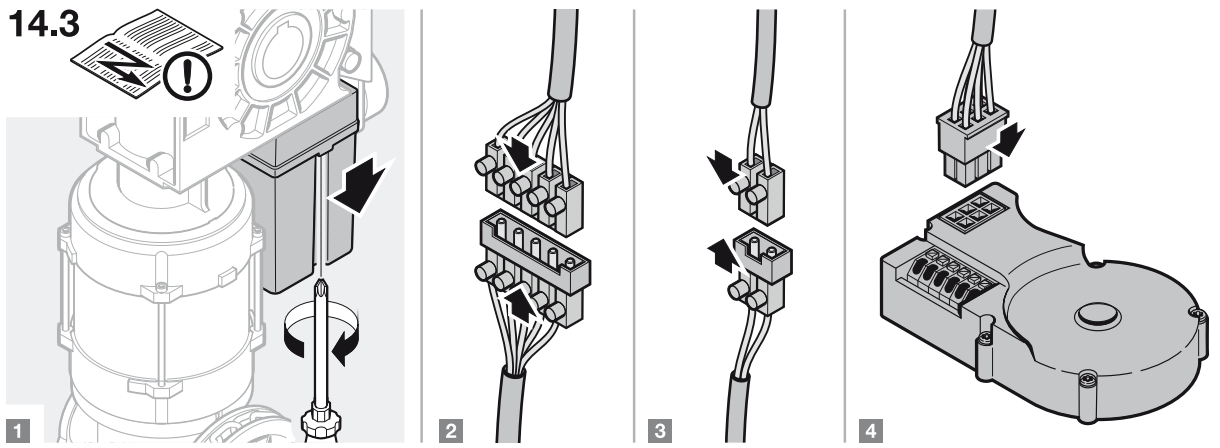

14.4

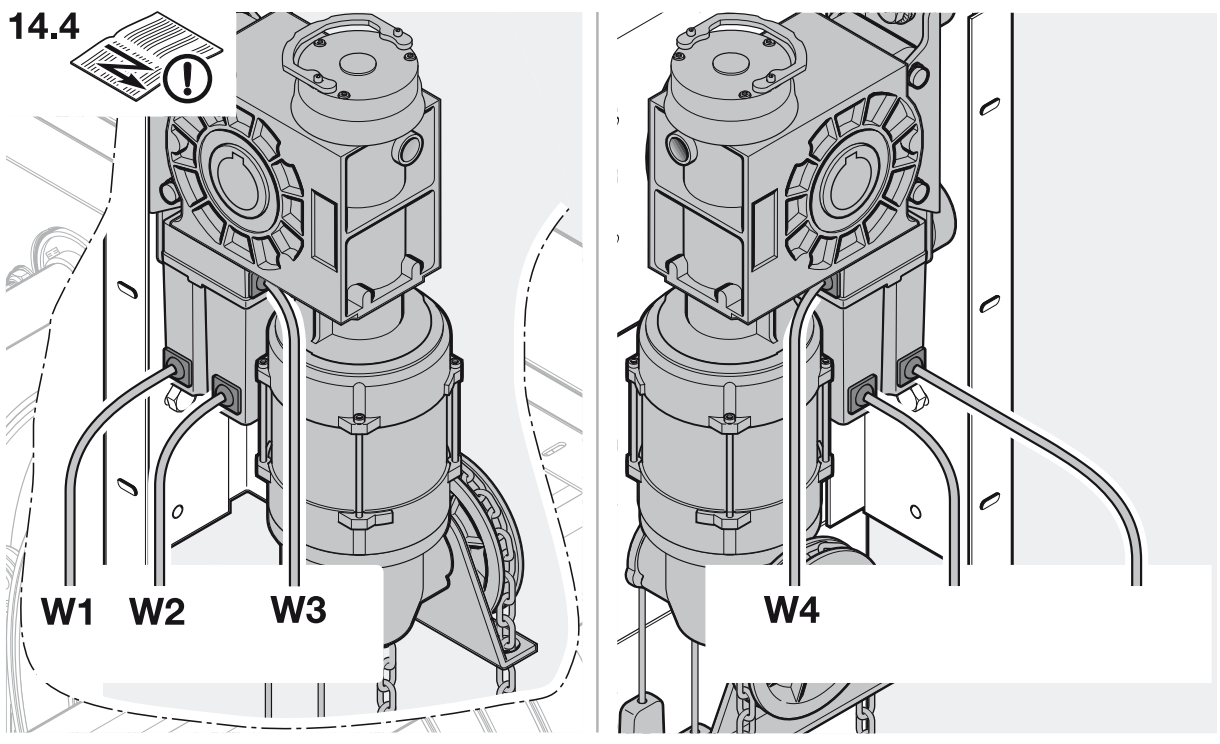

14.5a

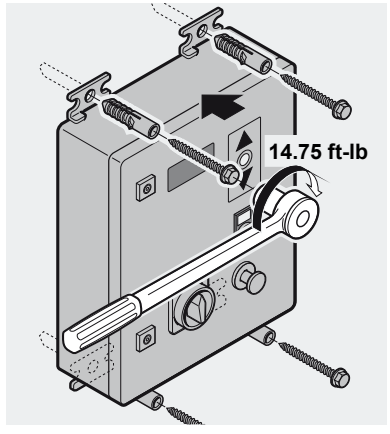
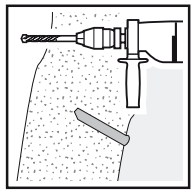

14.5b

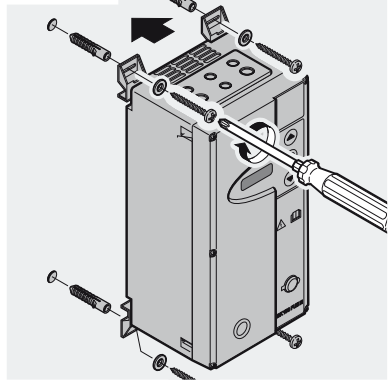

14.6

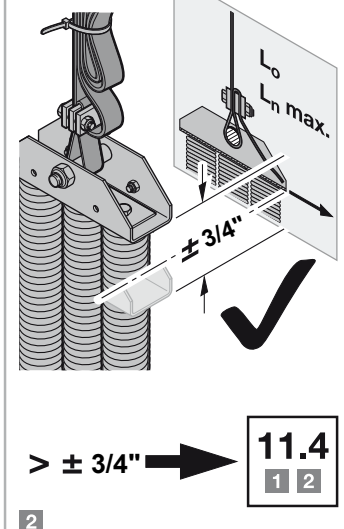
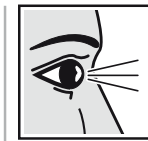
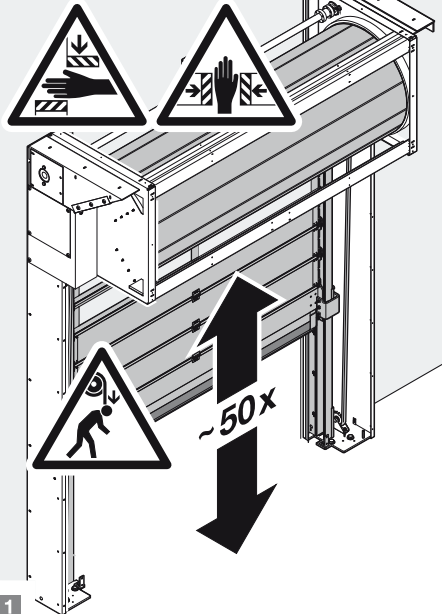

1

2

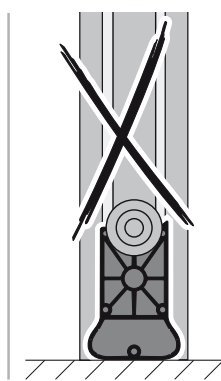
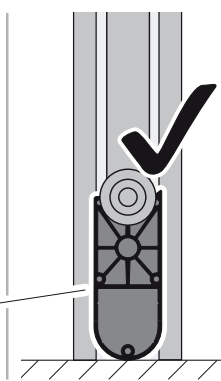
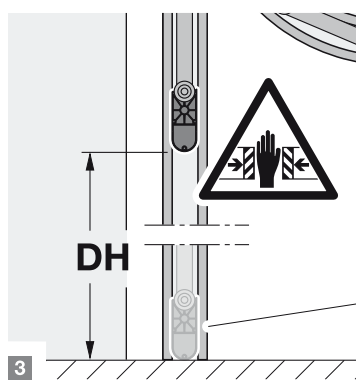

3

14.7

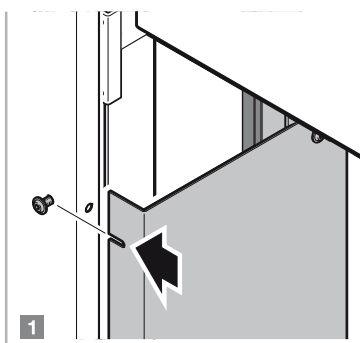
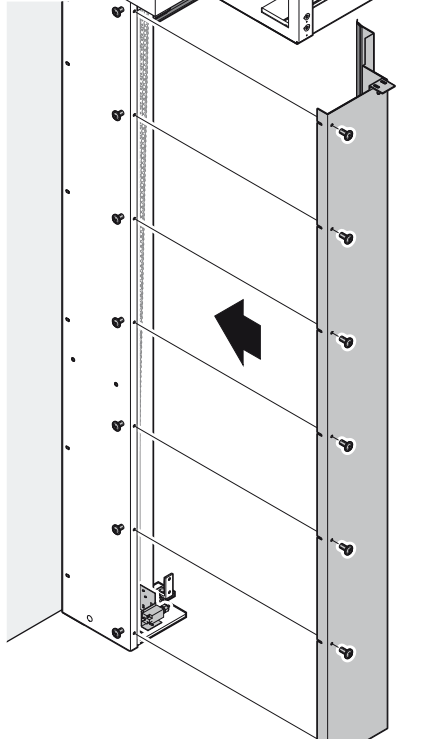

1

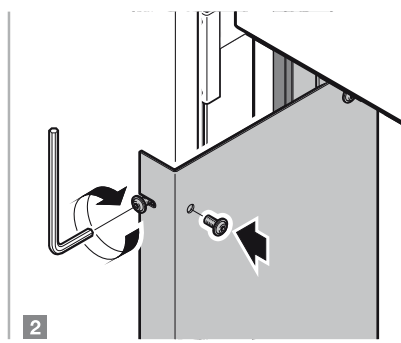

2

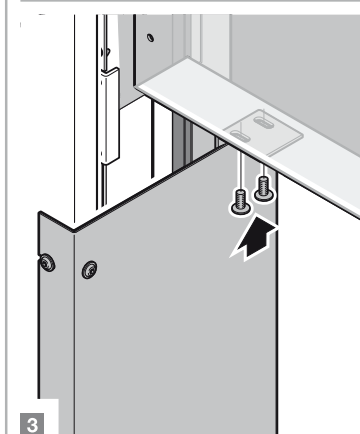

3

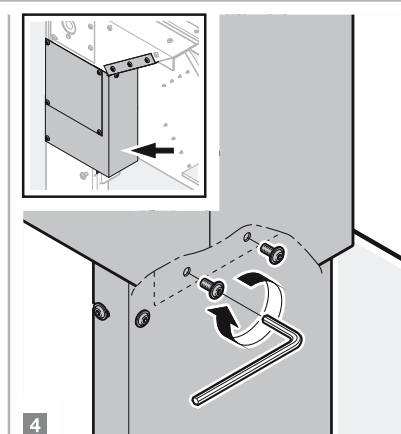

4

15a

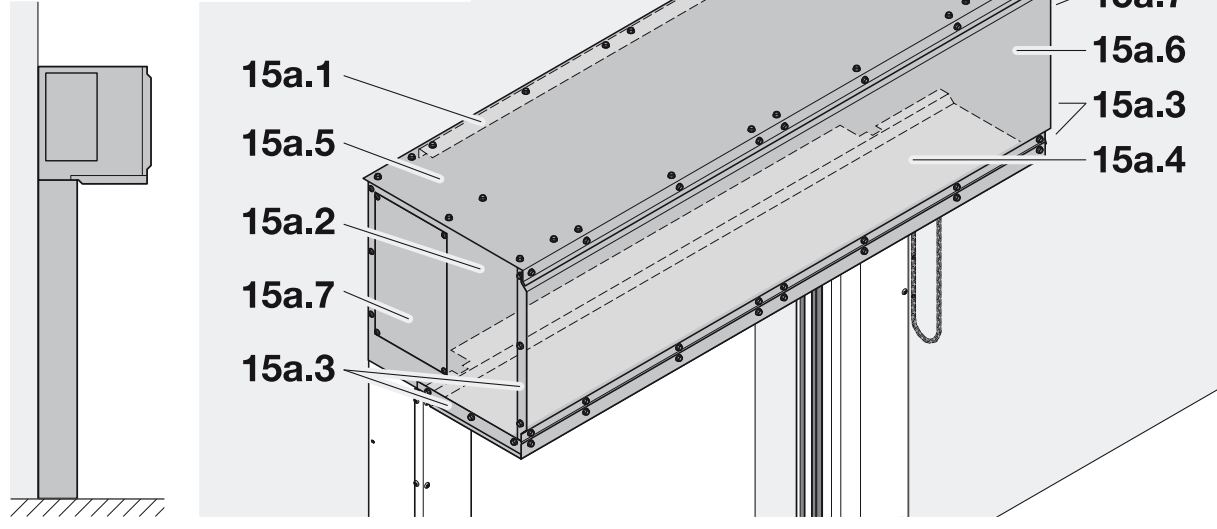
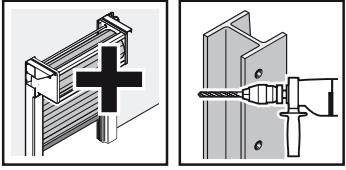

15a.1

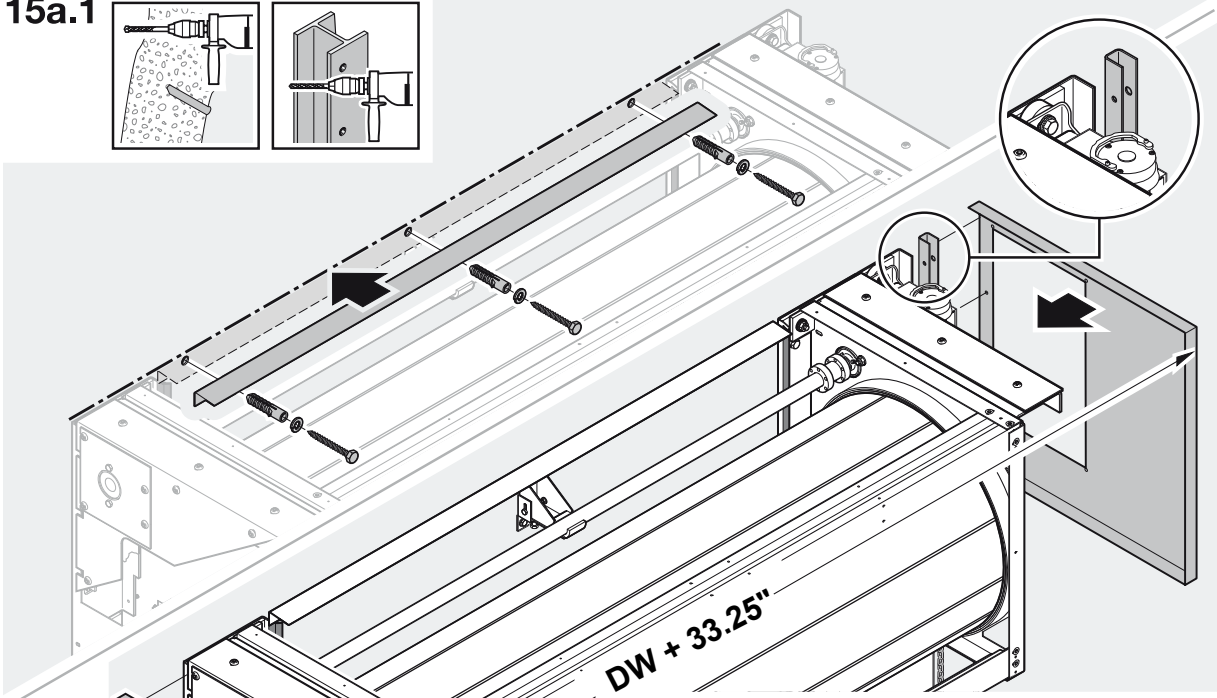
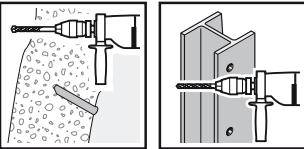

15a.2

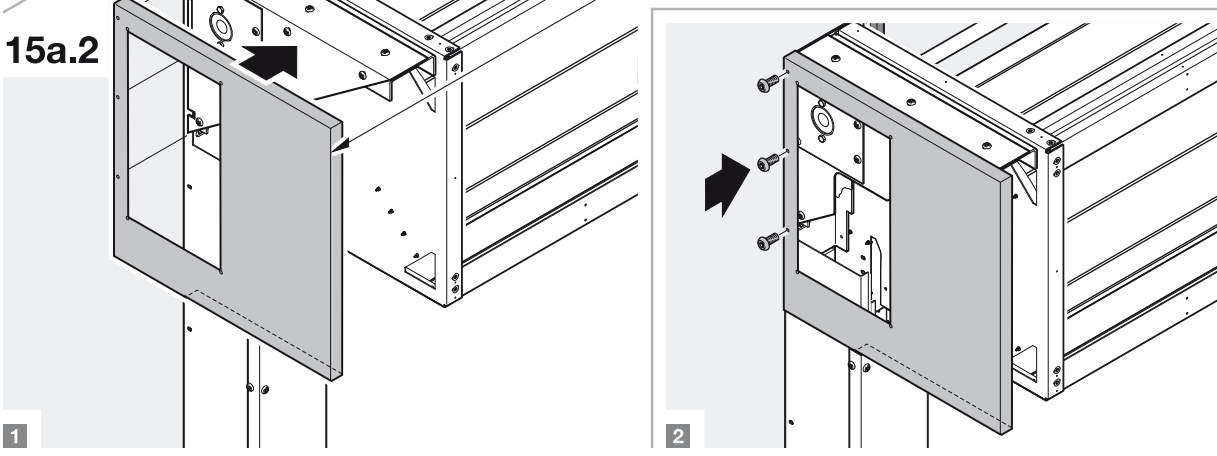

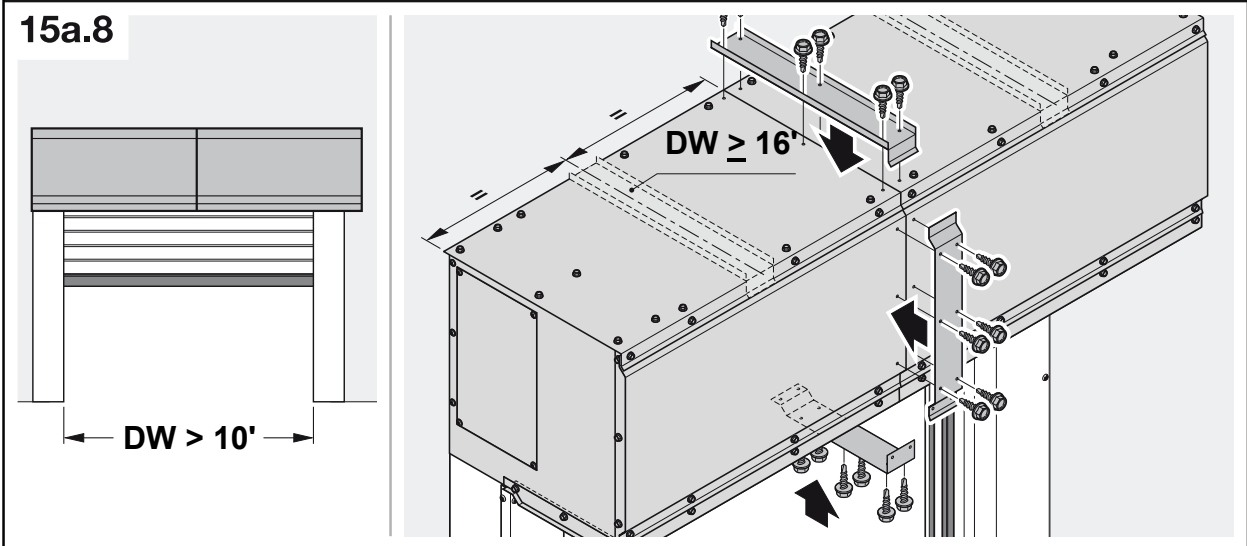
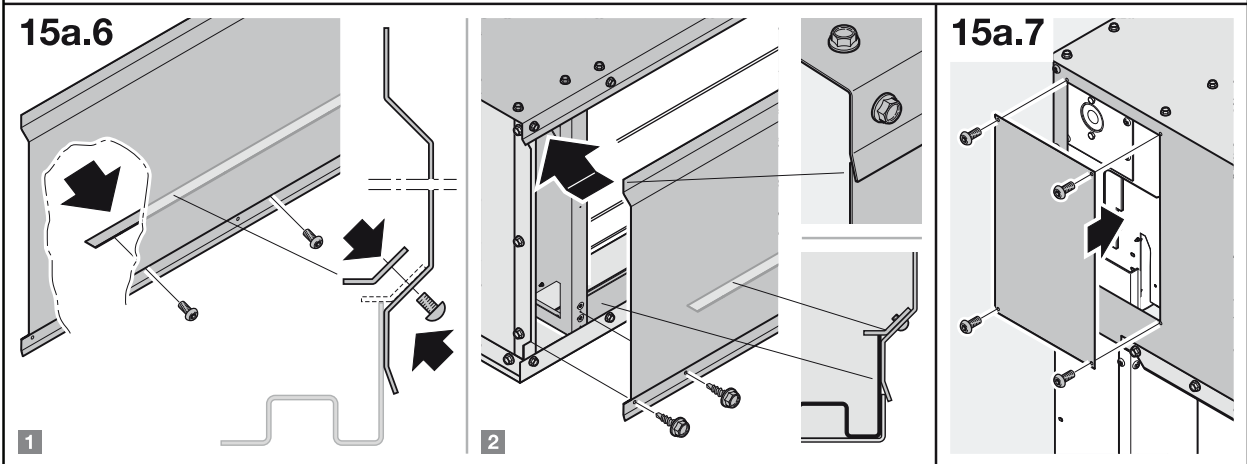
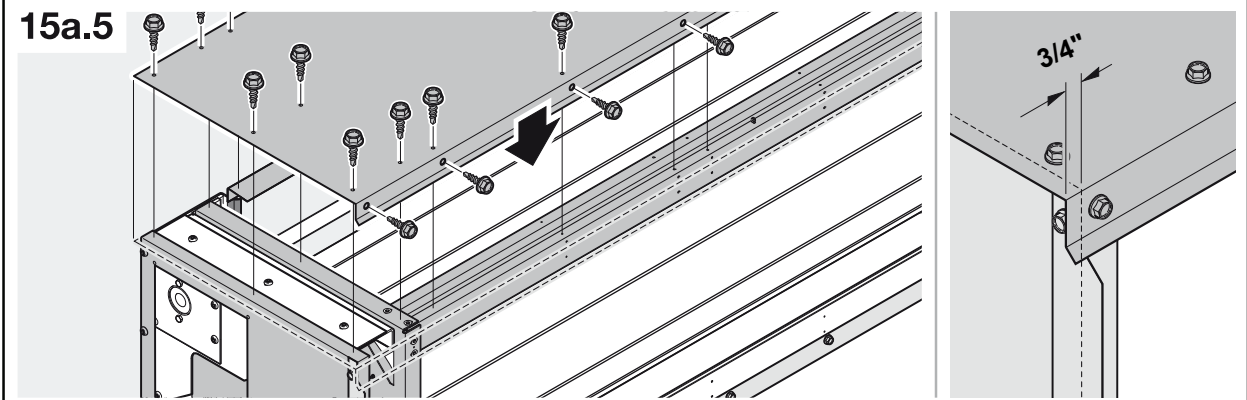
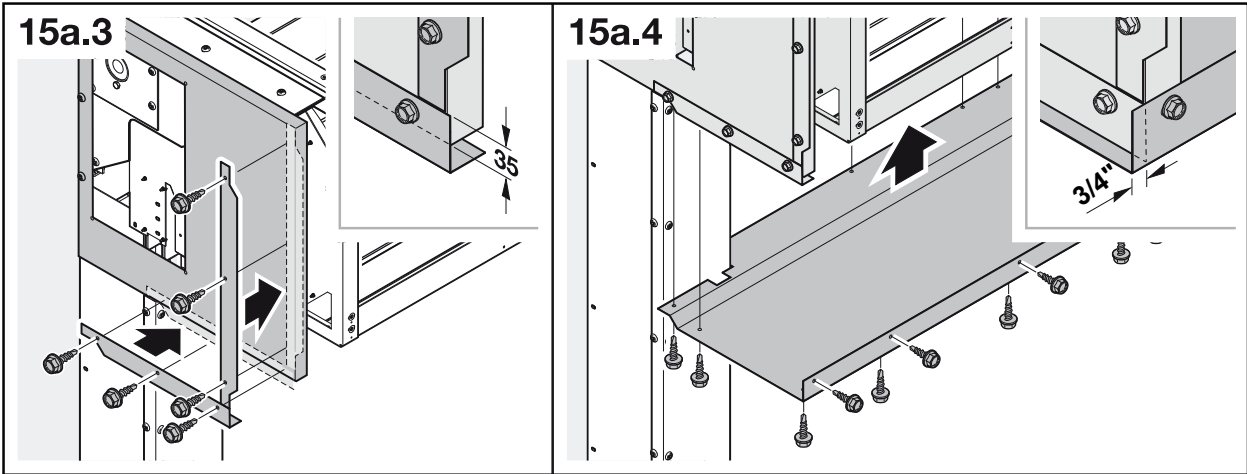

15b

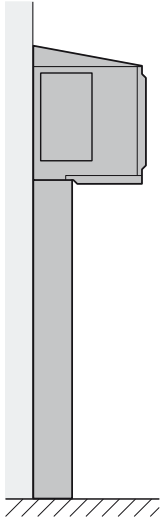
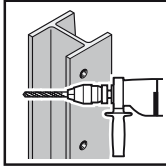
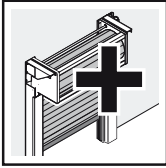

15b.1
15b.5
15b.2
15b.7
15b.3

15b.2
15b.7
15b.6
15b.3
15b.4

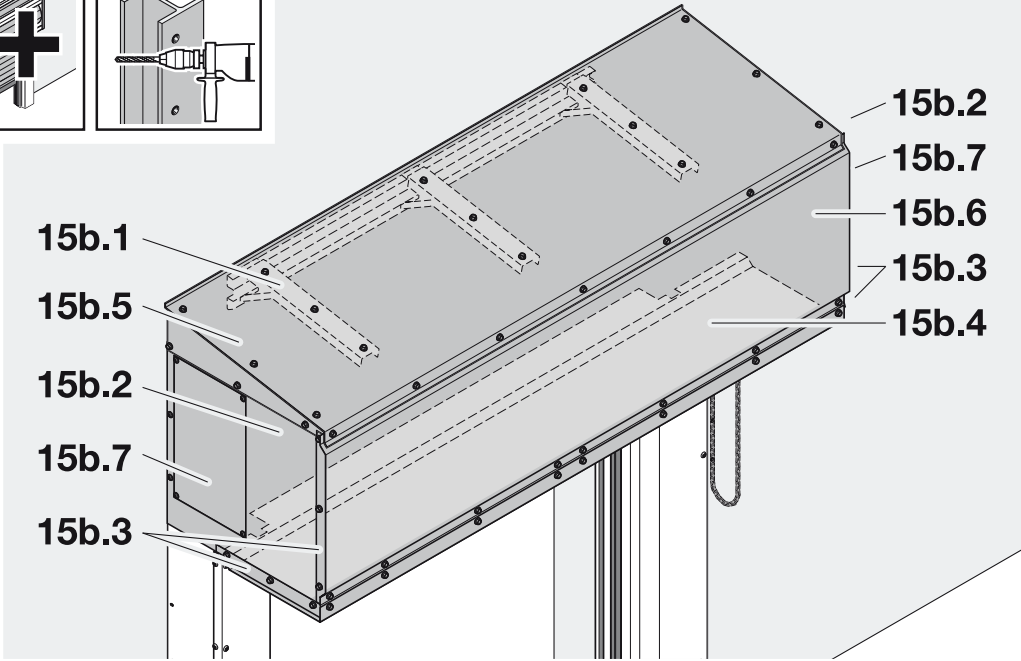

15b.1

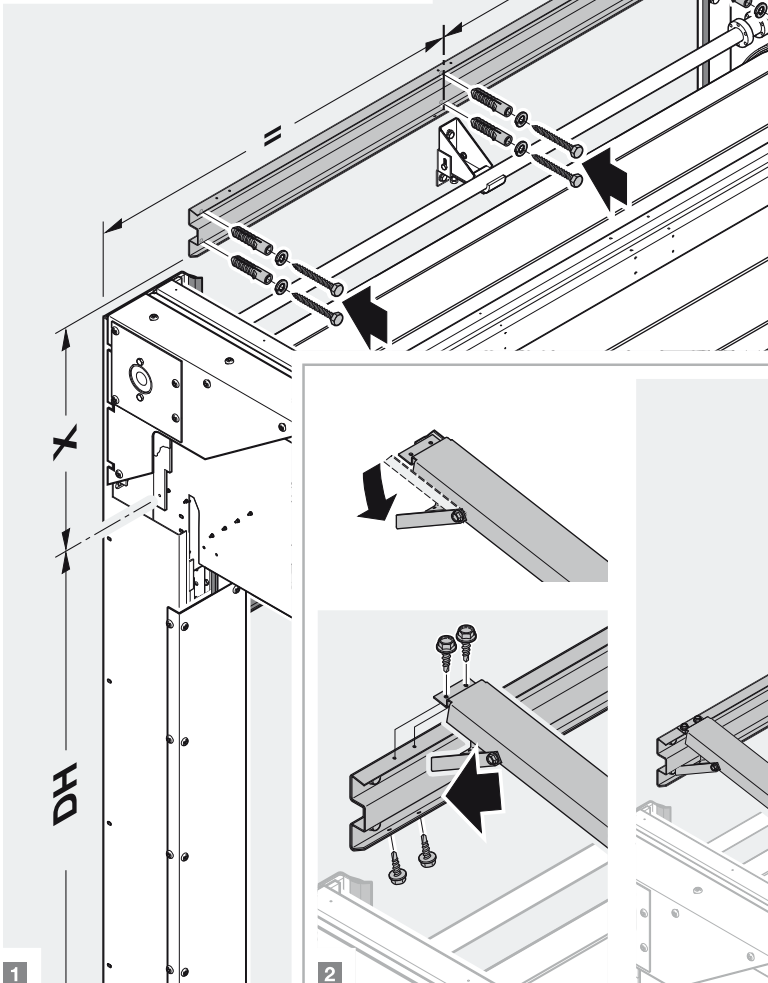
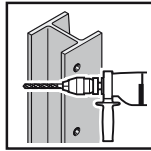
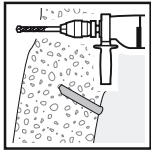

	X
DH ≤ 16'	34"
DH > 16'	36"

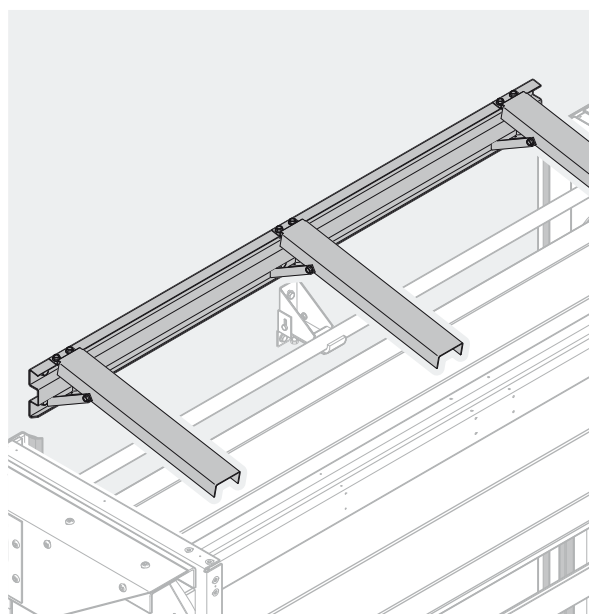
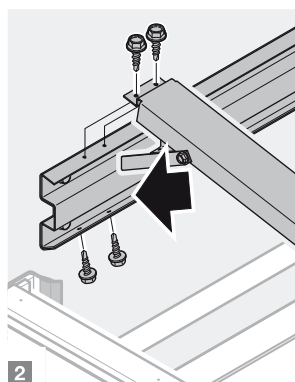
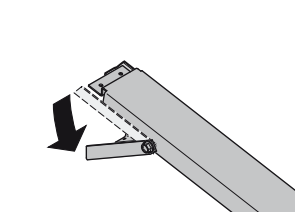

1

2

15b.2

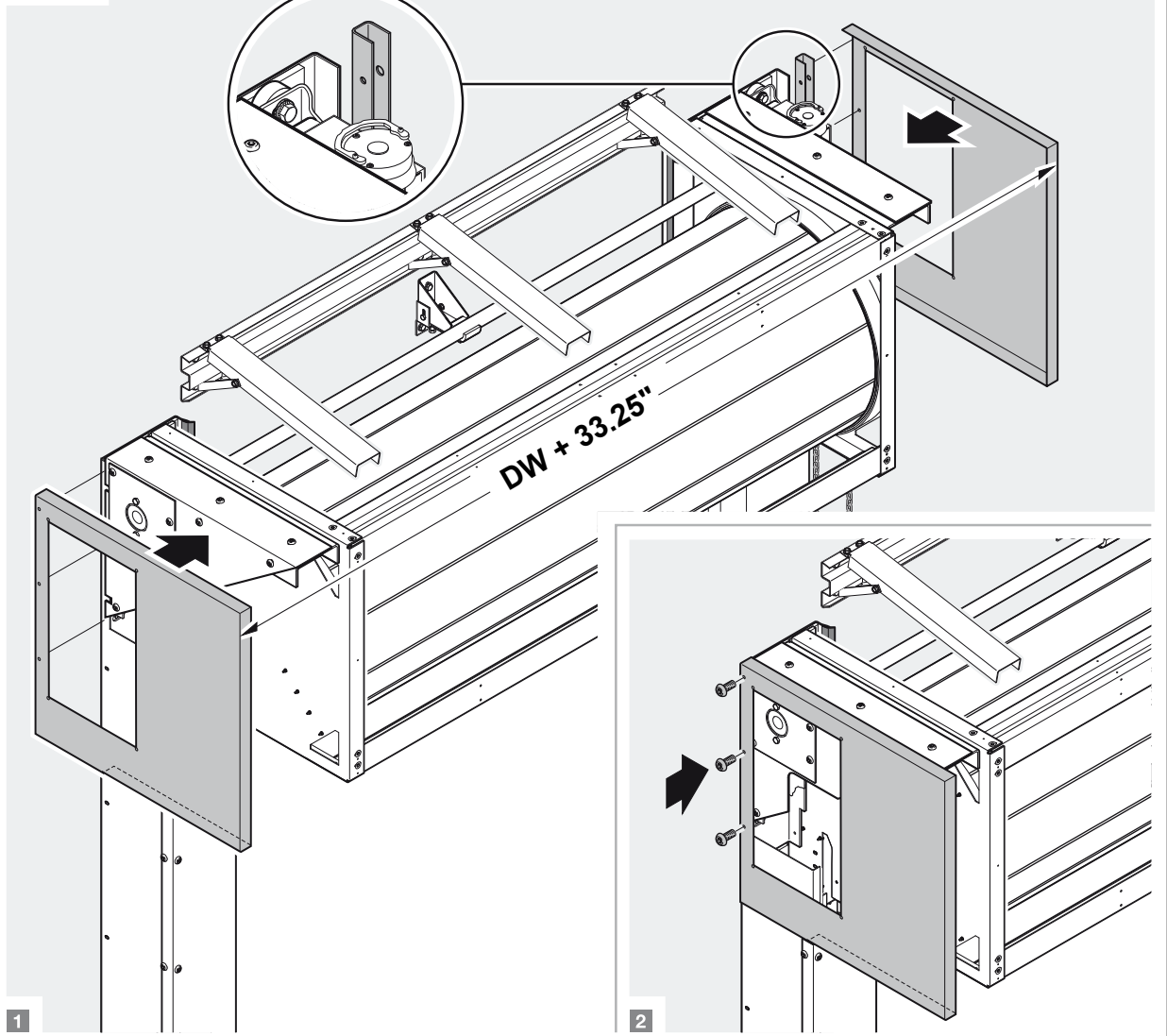

15b.3

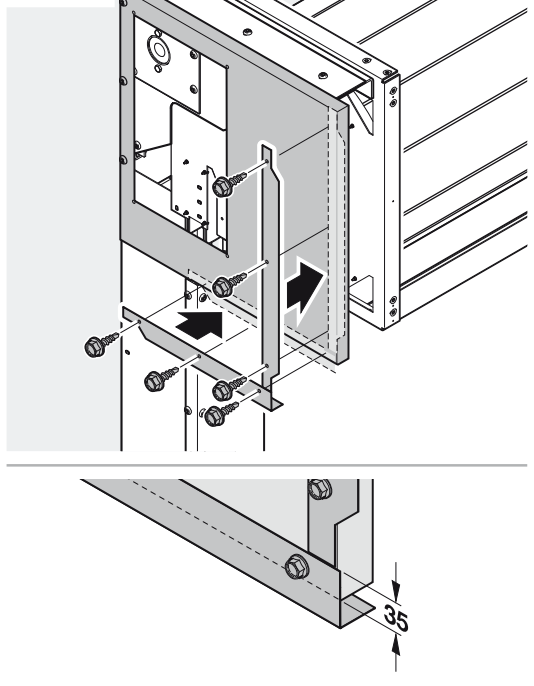

15b.4

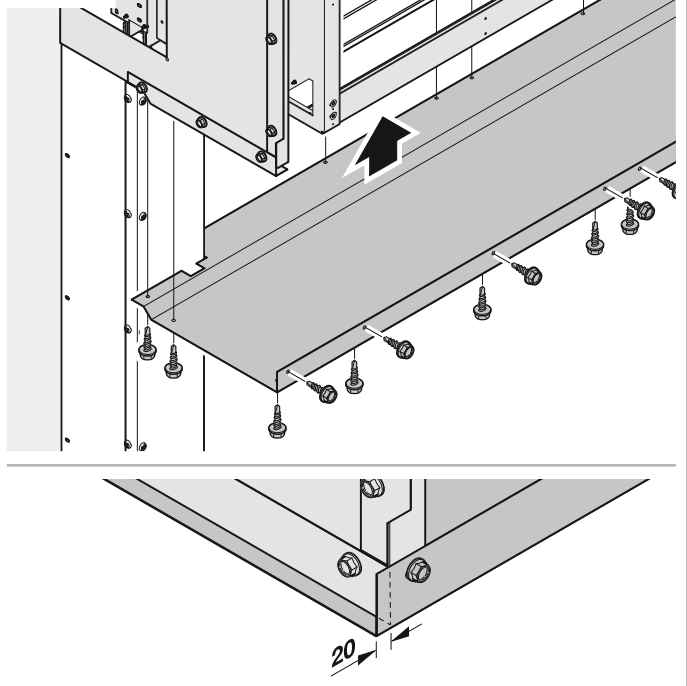

15b.5

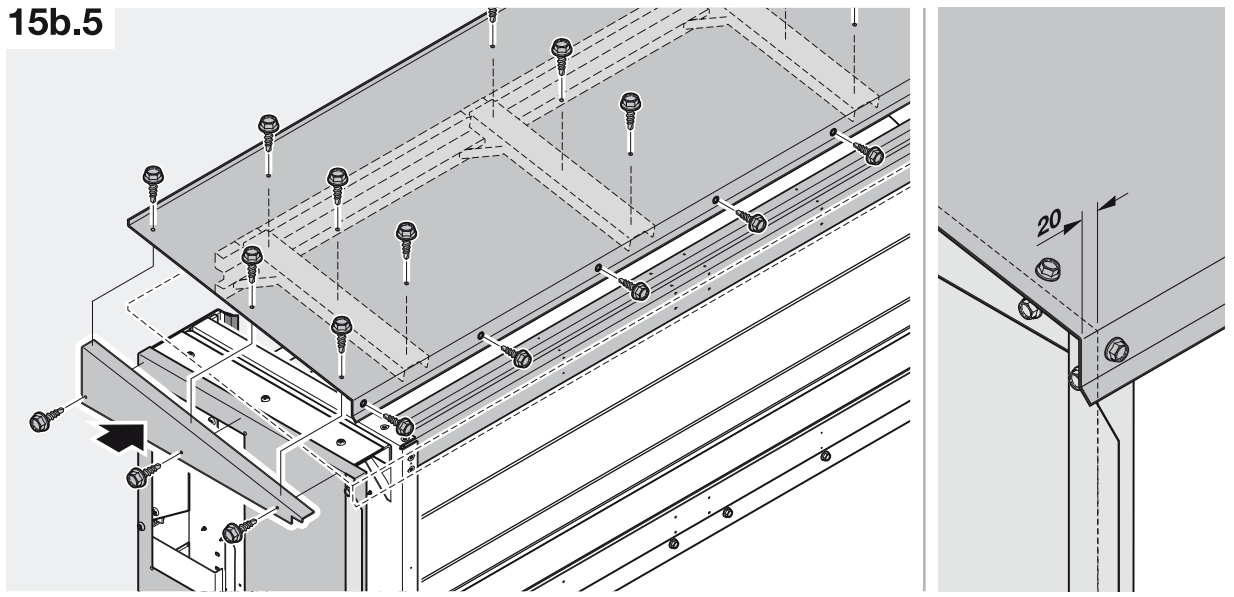

15b.6

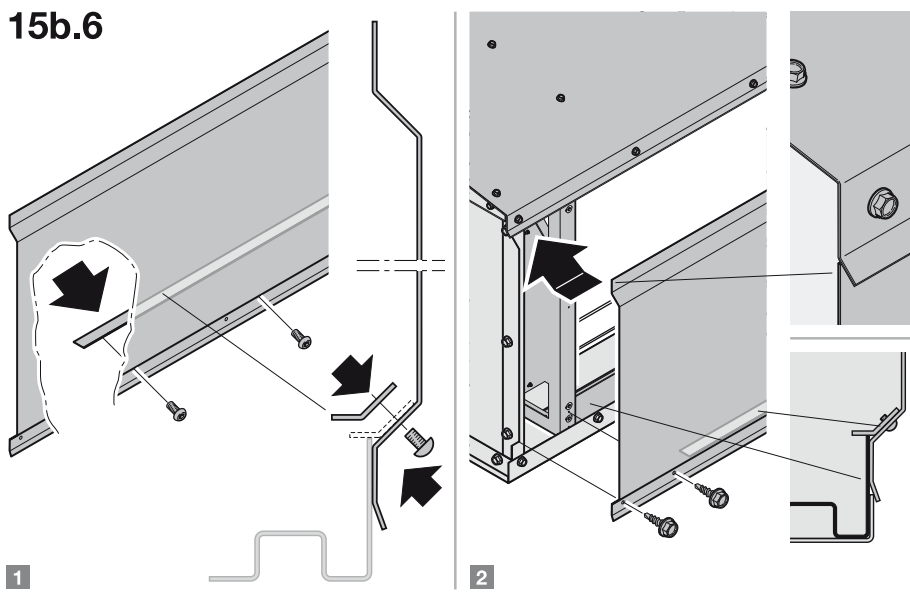

15b.7

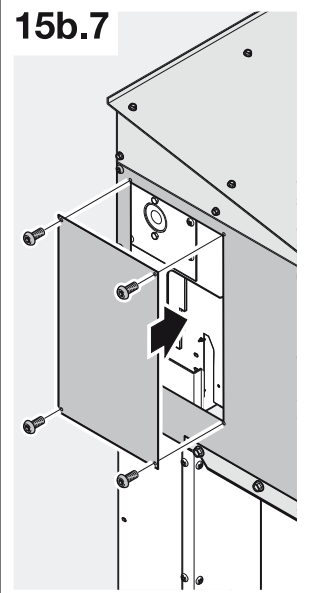

15b.8

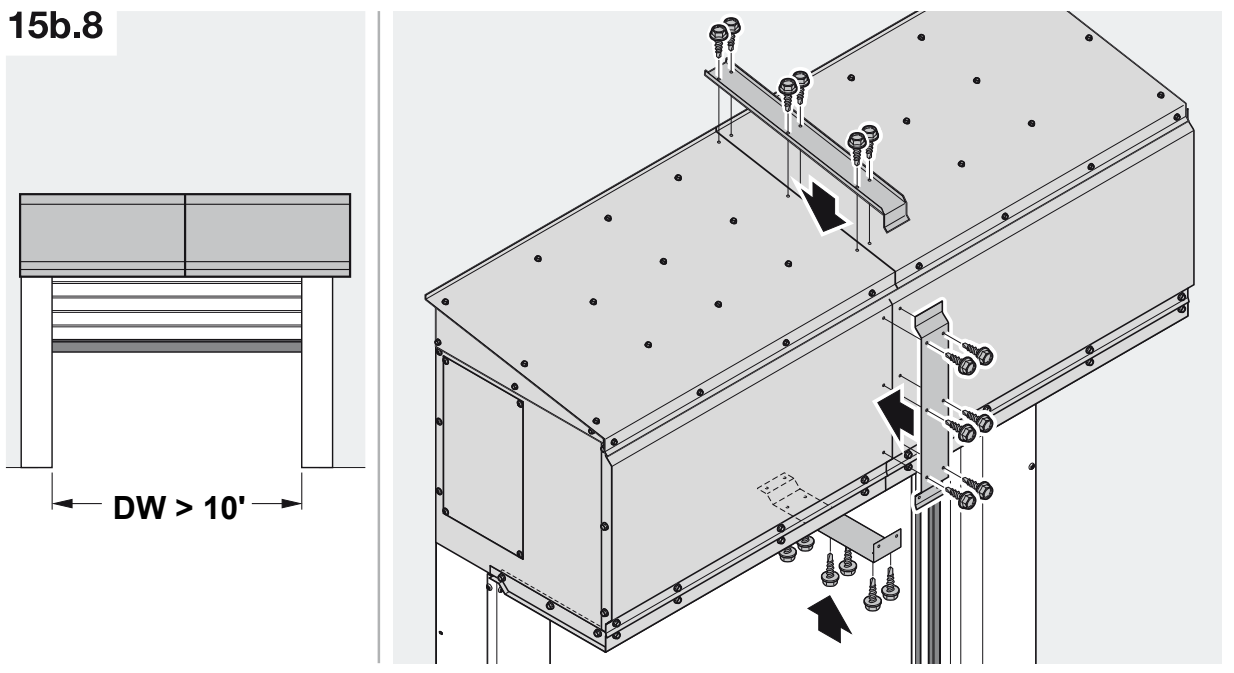

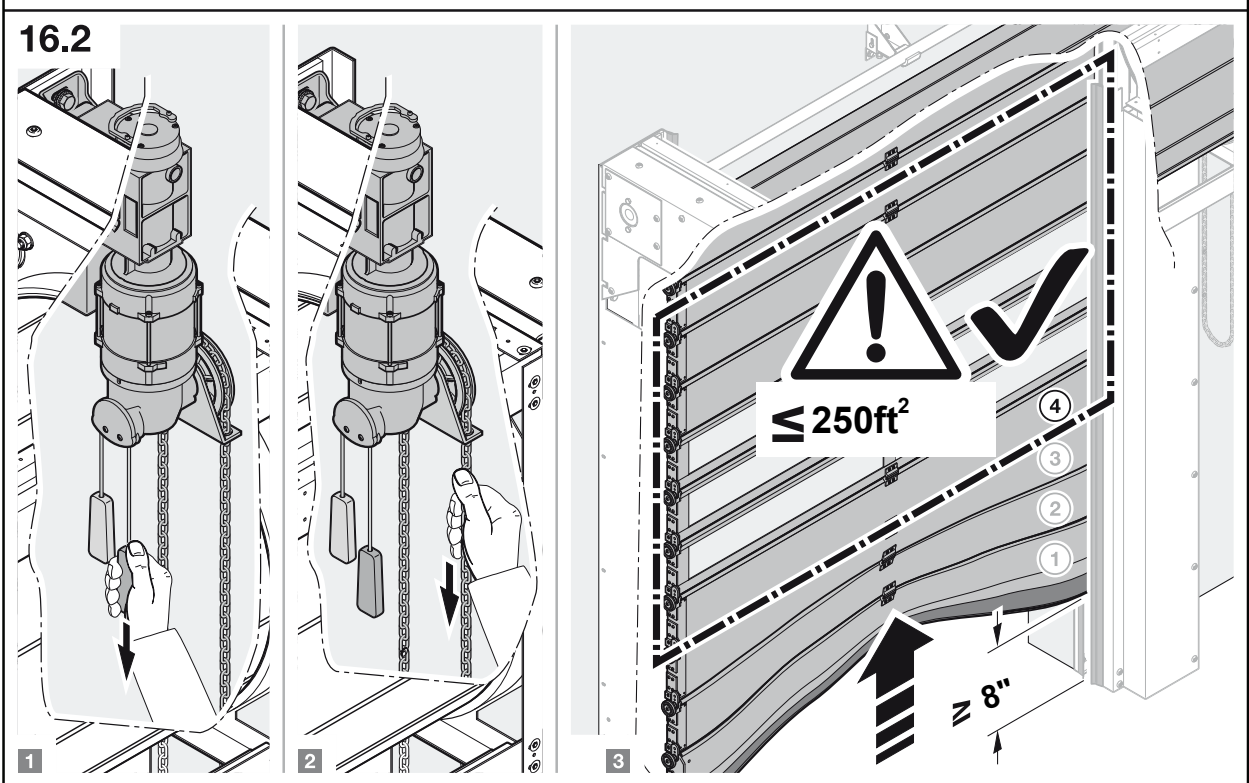
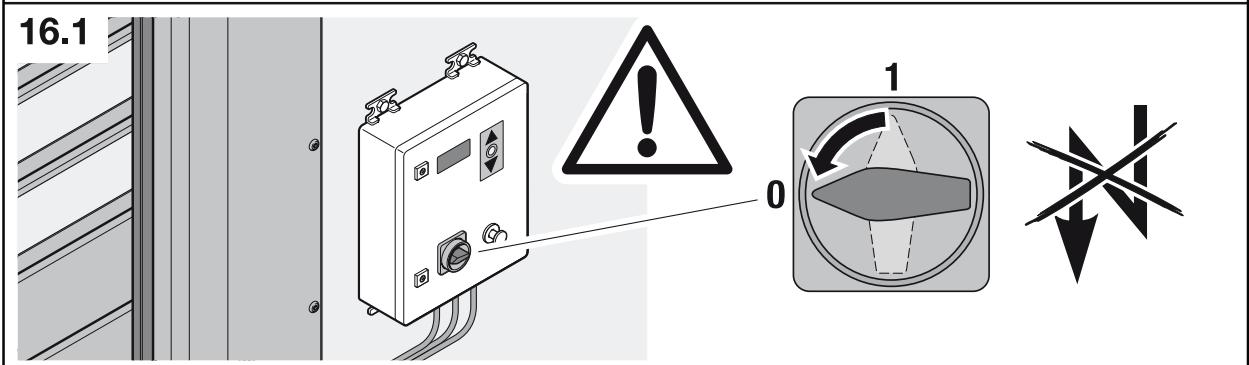
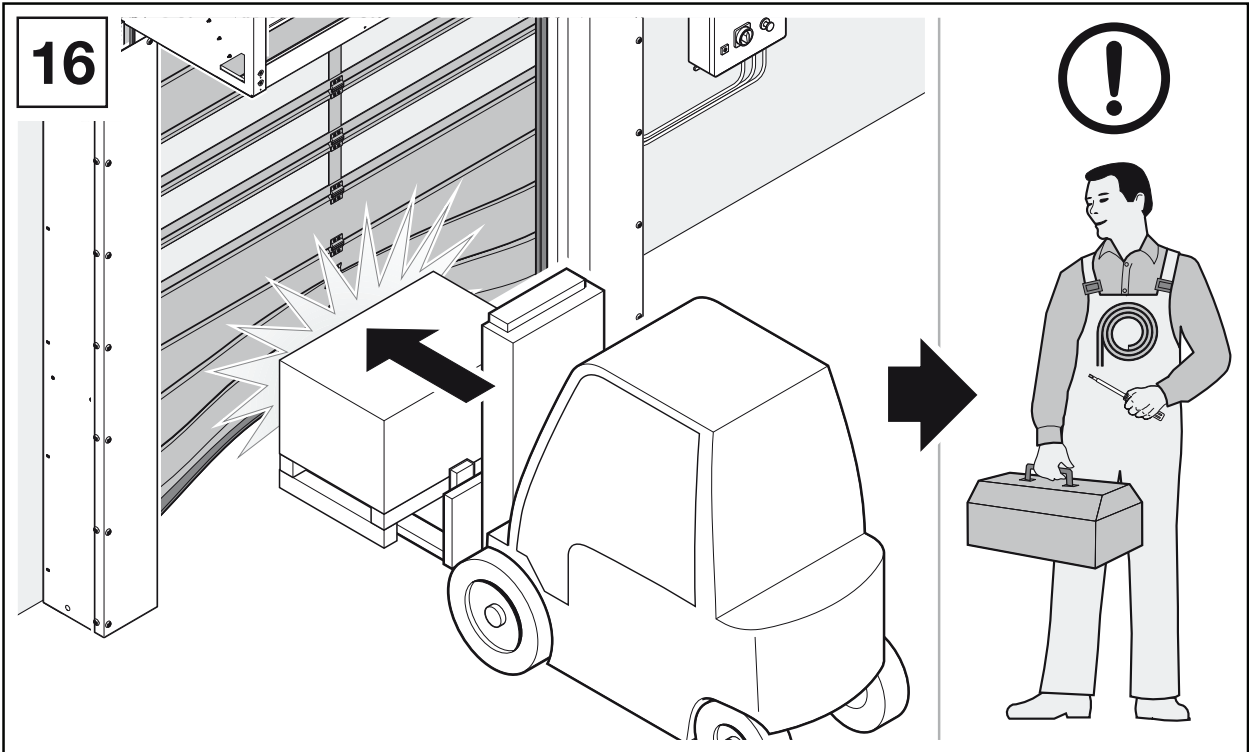

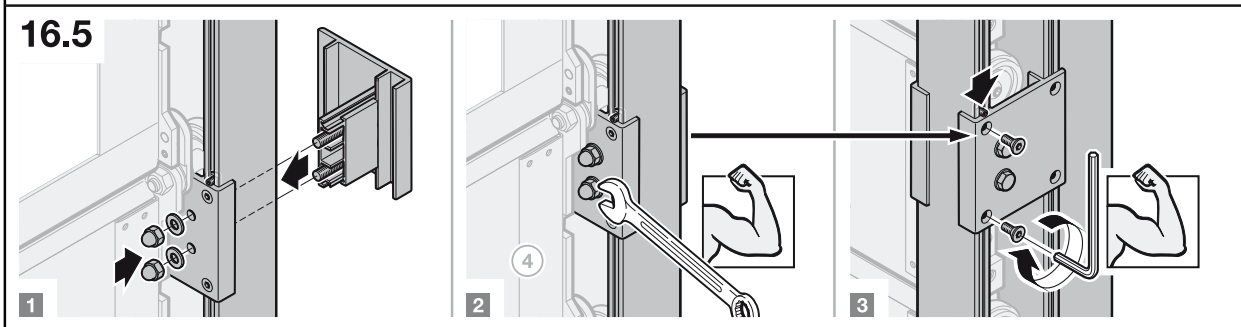
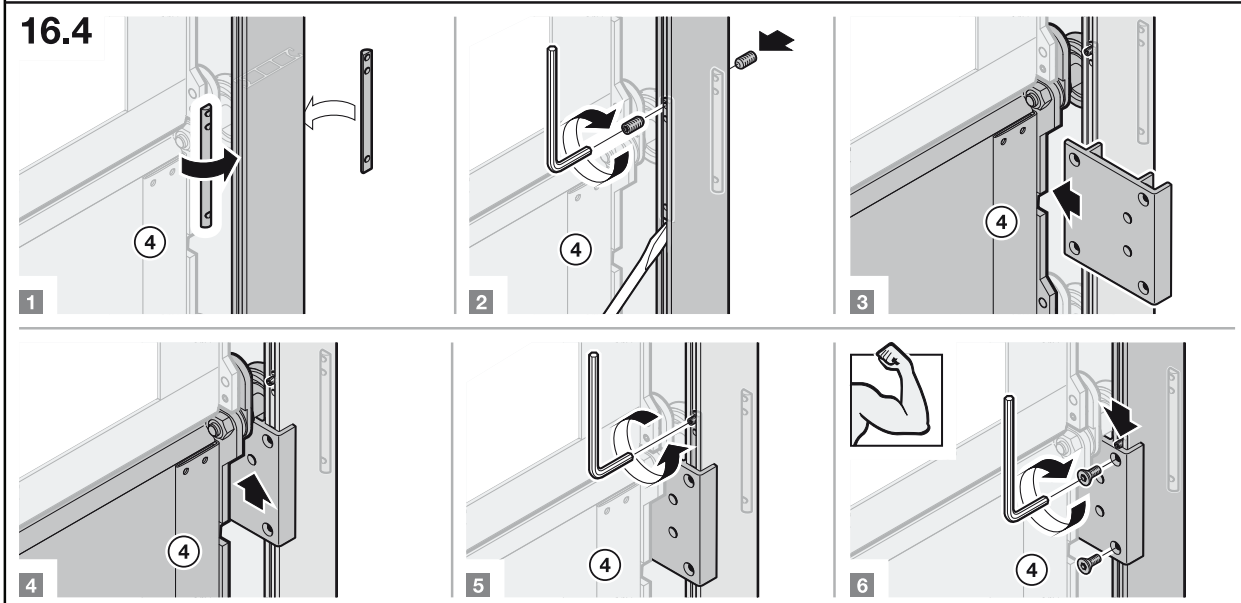
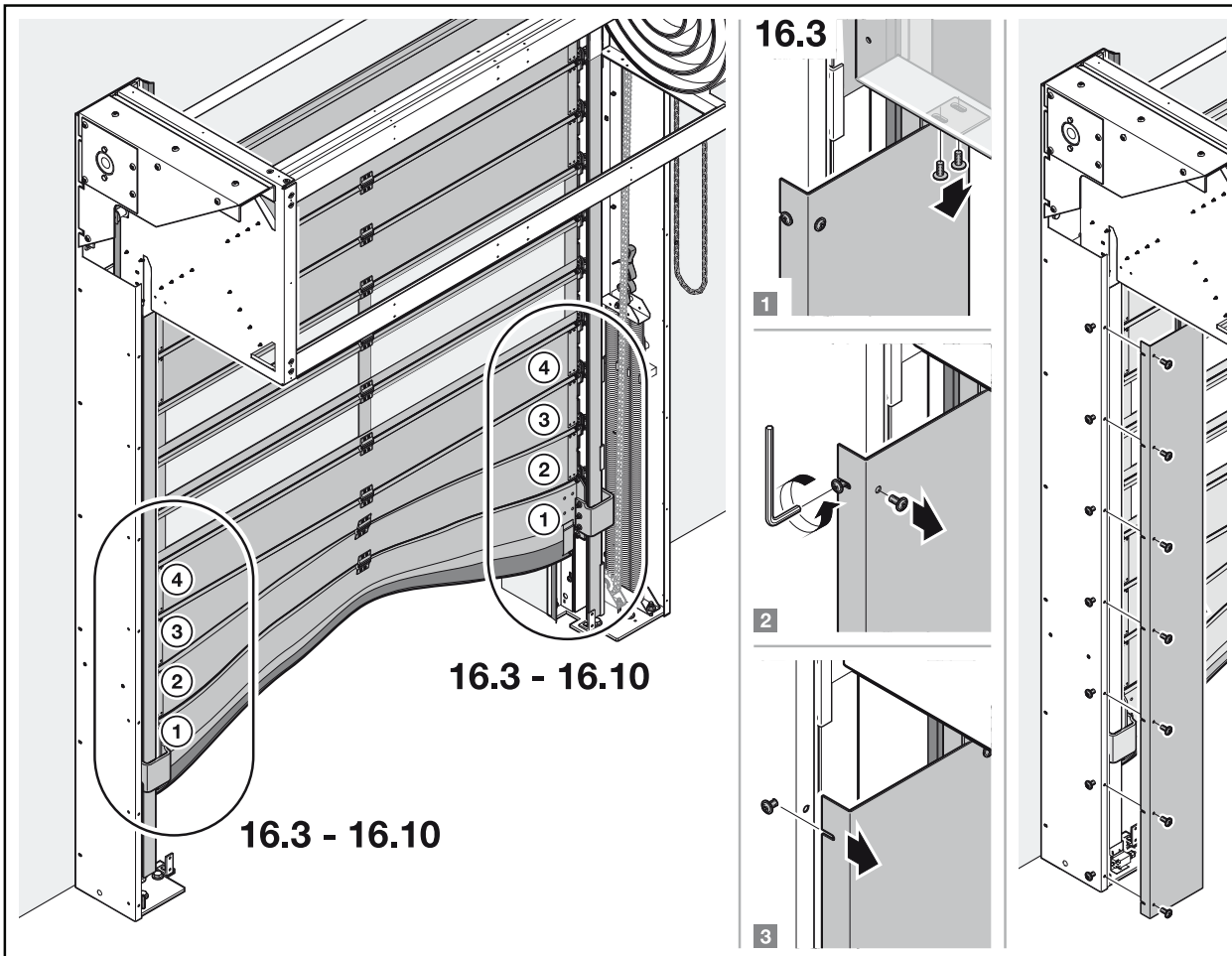

16.6

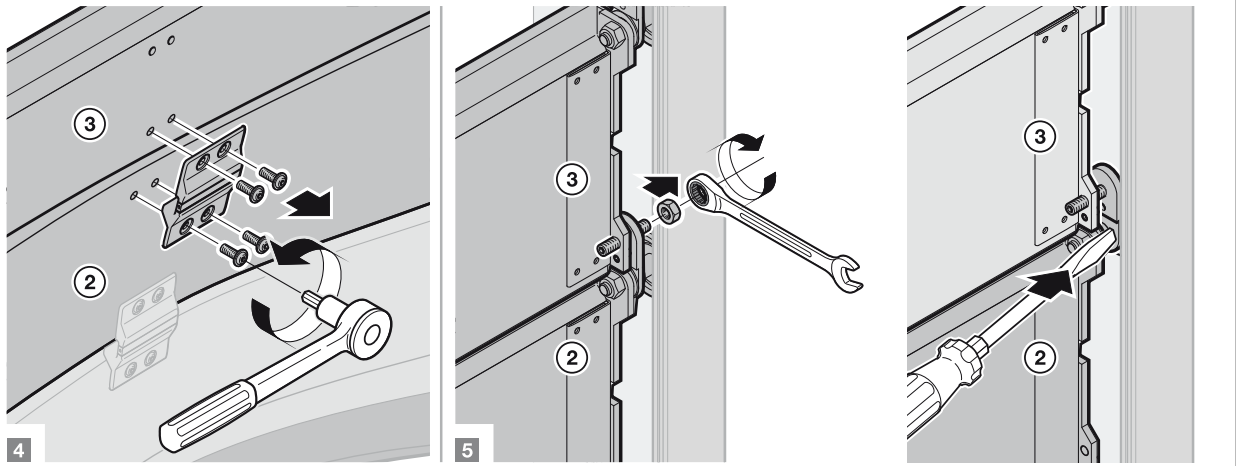
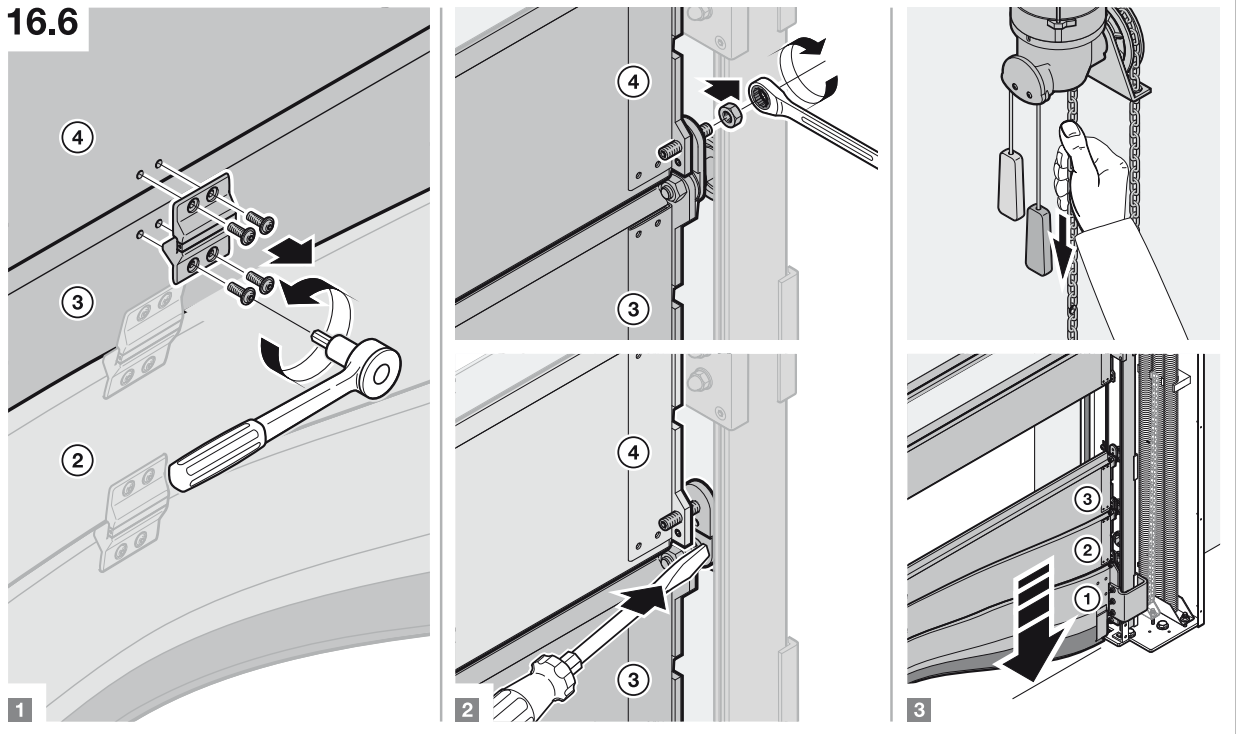

16.7

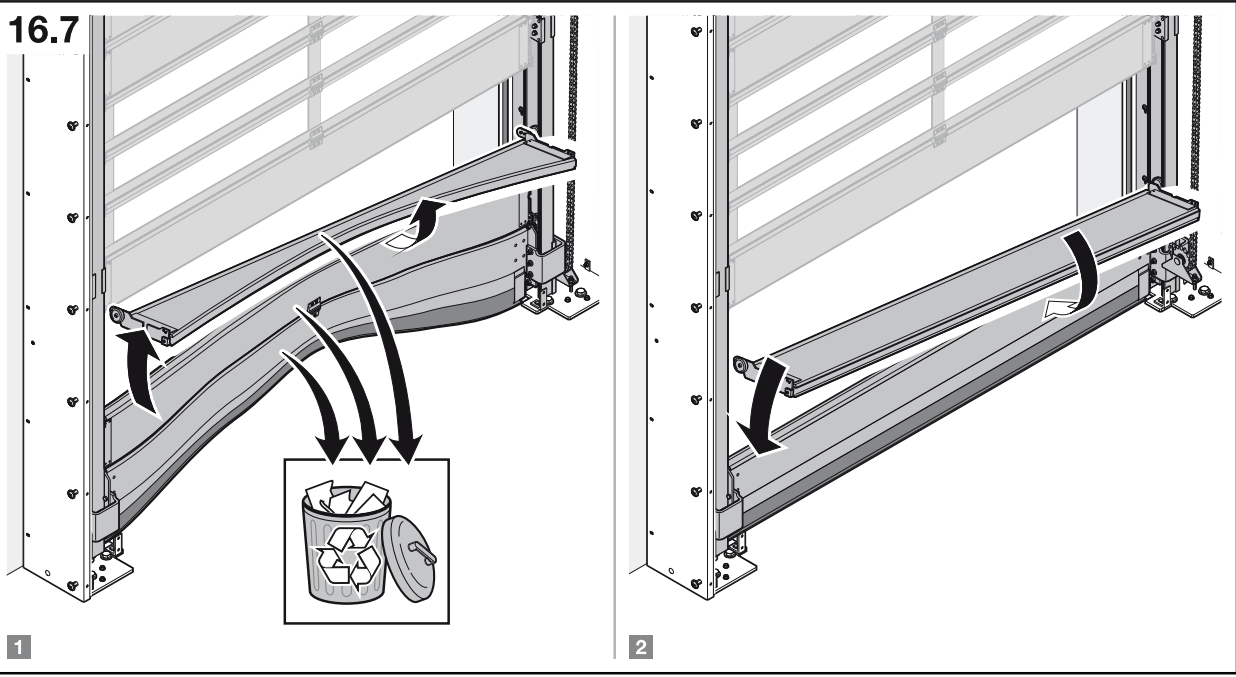

16.8

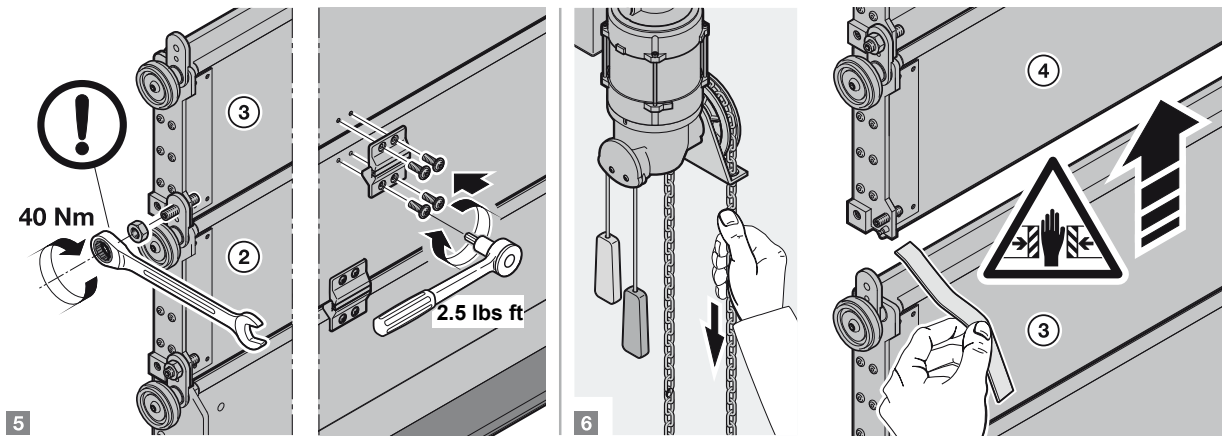
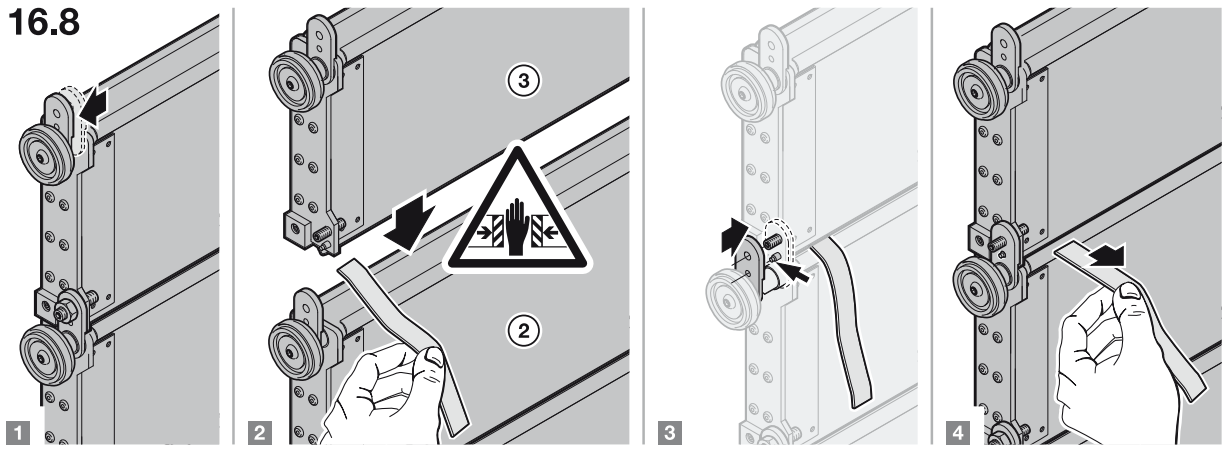

16.9

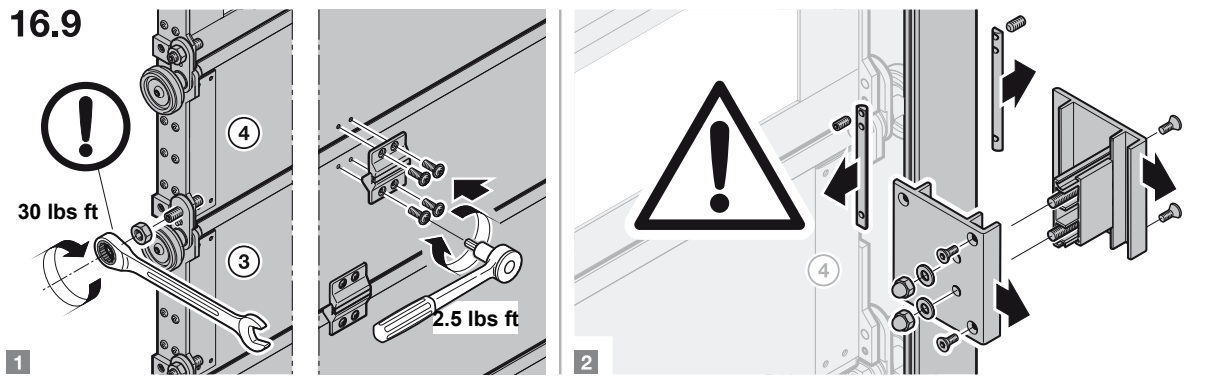

16.10

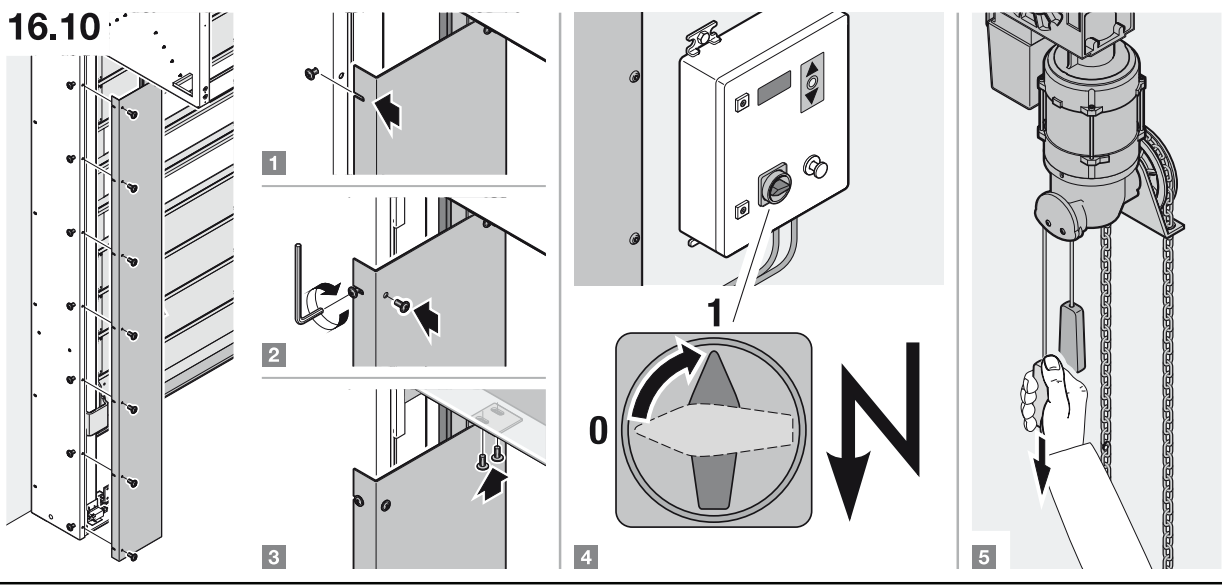

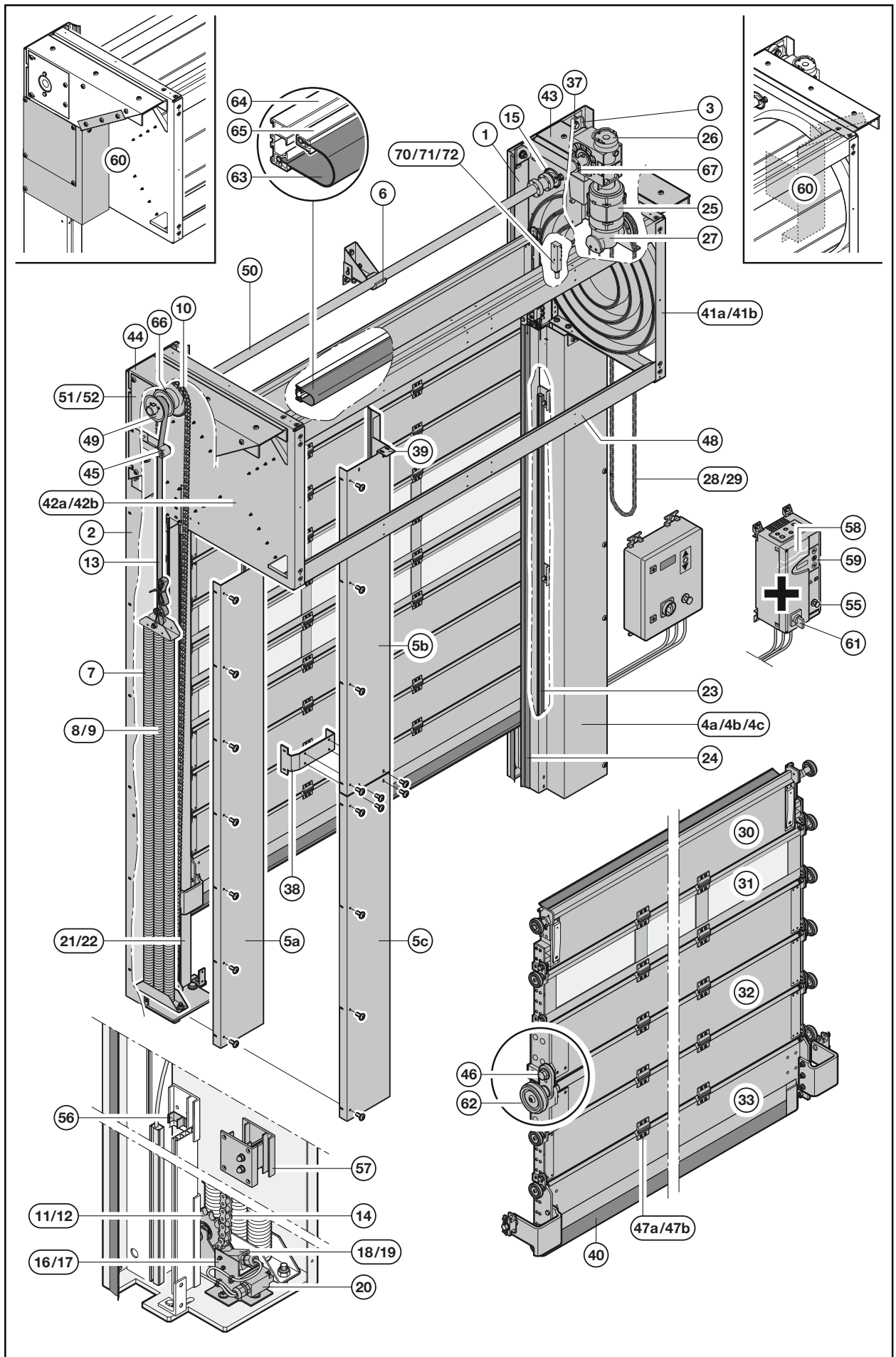

Innovative Door Systems

HÖRMANN

Our promise to you

As one of the world's leading manufacturers of doors, we're committed to providing the best quality, value, and selection. Whether industrial or commercial, retail automotive, parking garages, transit, waste management,

fire stations or food processing, we have the door you're looking for. The Hörmann product line has a door for any application, from one manufacturer.



Hörmann, Burgettstown, PA



Hörmann, Barrie, Ontario, Canada

Connect with us!



Visit our website for more information!

Hörmann High Performance Doors
Starpointe Business Park • 117 Starpointe Boulevard
Burgettstown, PA 15021-9506
Phone: 800.365.3667 • 724.385.9150 • Fax: 724.385.9151
www.hormann.us • Email: info2@hormann.us



USGBC
MEMBER

Environmental commitment has been part of our corporate culture for decades. From our manufacturing processes to the products we make.

In everything we do we strive to minimize energy and use of resources through efficient processes, long-lasting quality and innovative engineering.

Hörmann TNR Doors
200 Fairview Road • Unit # 2
Barrie, Ontario L4N 8X8
Phone: 866.792.9968 • Fax: 705.735.9564
www.TNRdoors.com • Email: info@tnrdoors.com

We reserve the right to change specifications without notice. ©Hörmann Flexon LLC