

EN

Instructions for Fitting, Operating and Maintenance

High-Speed Door SG 5000 H/V 100 Iso Speed Cold

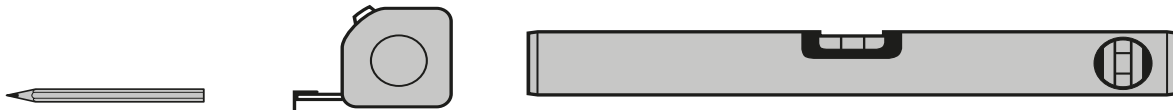
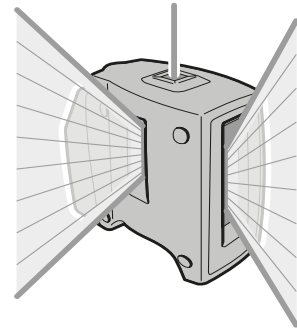
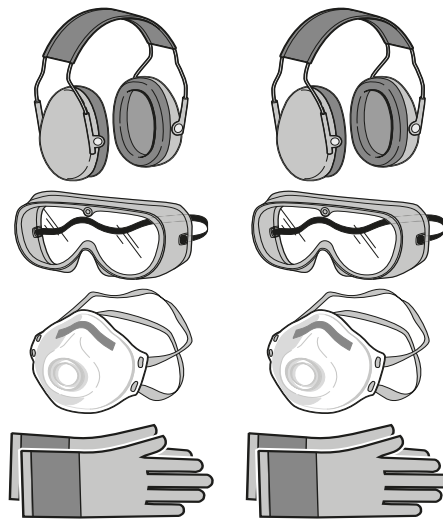
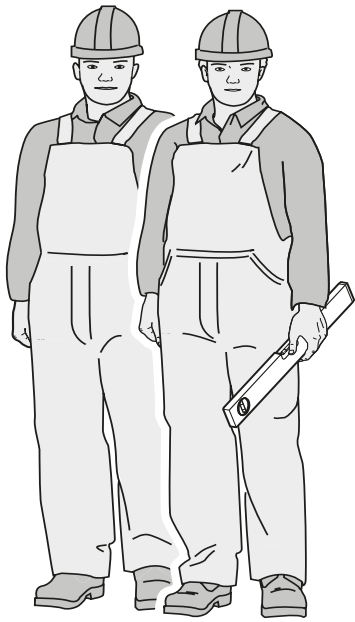

Ø 16 

Ø 8; Ø 10 

7; 10; 13; 17 

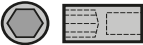
13; 15; 17; 19 

T20; T30 

#2 



2.5; 3; 4; 5 

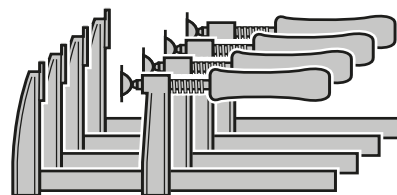
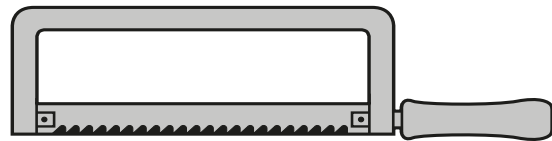
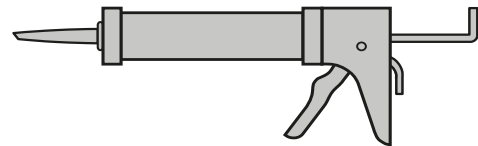
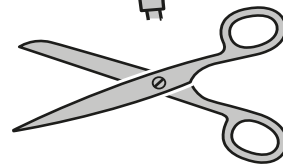
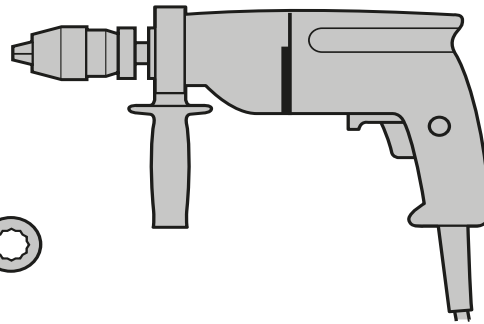
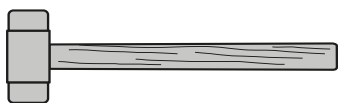

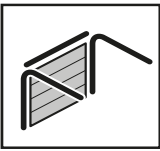

**PARTS RECEIVED WITH AN
"H" CONFIGURATION**

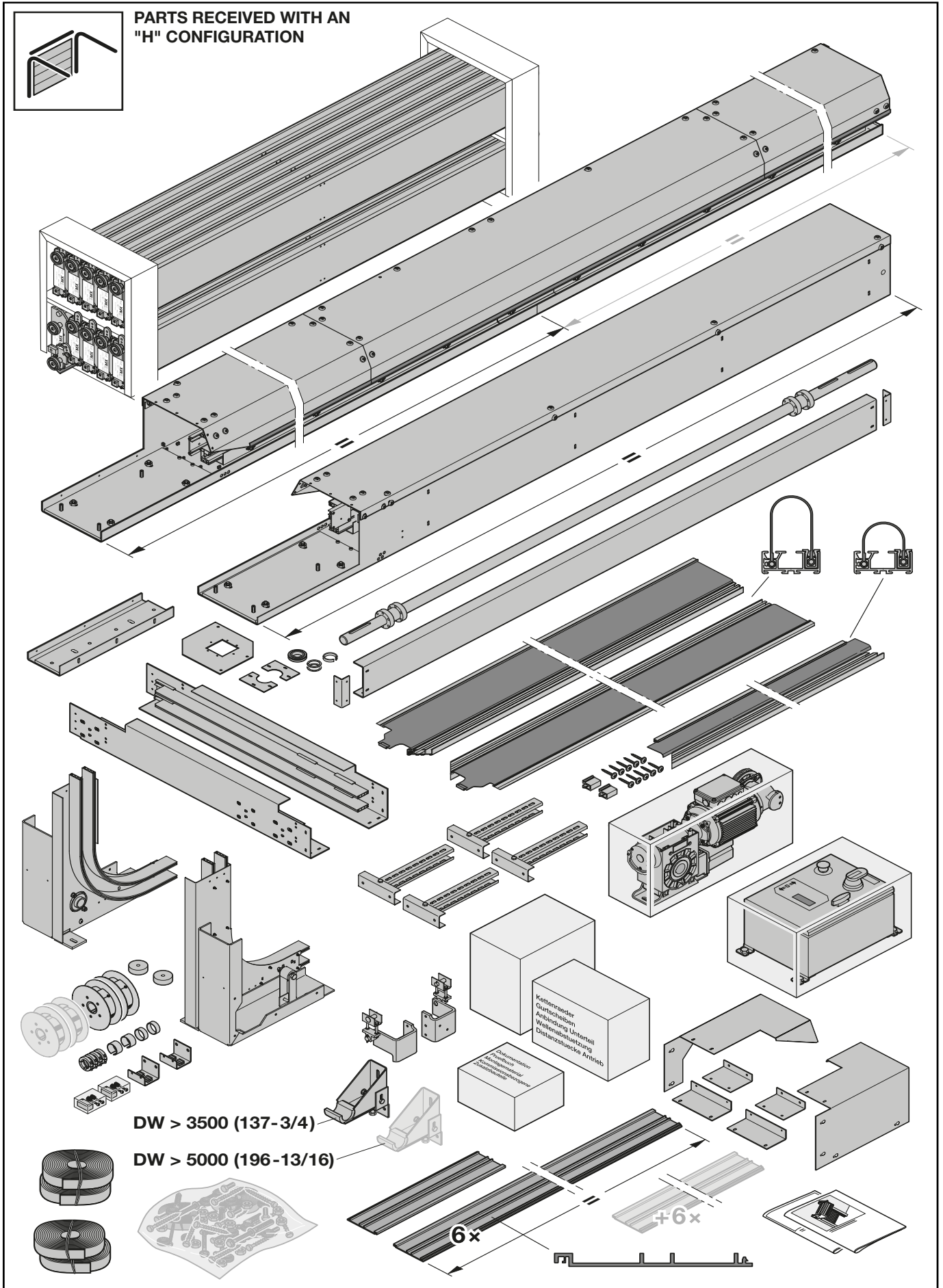

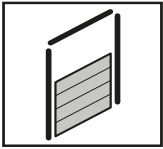

**PARTS RECEIVED WITH AN
"V" CONFIGURATION**

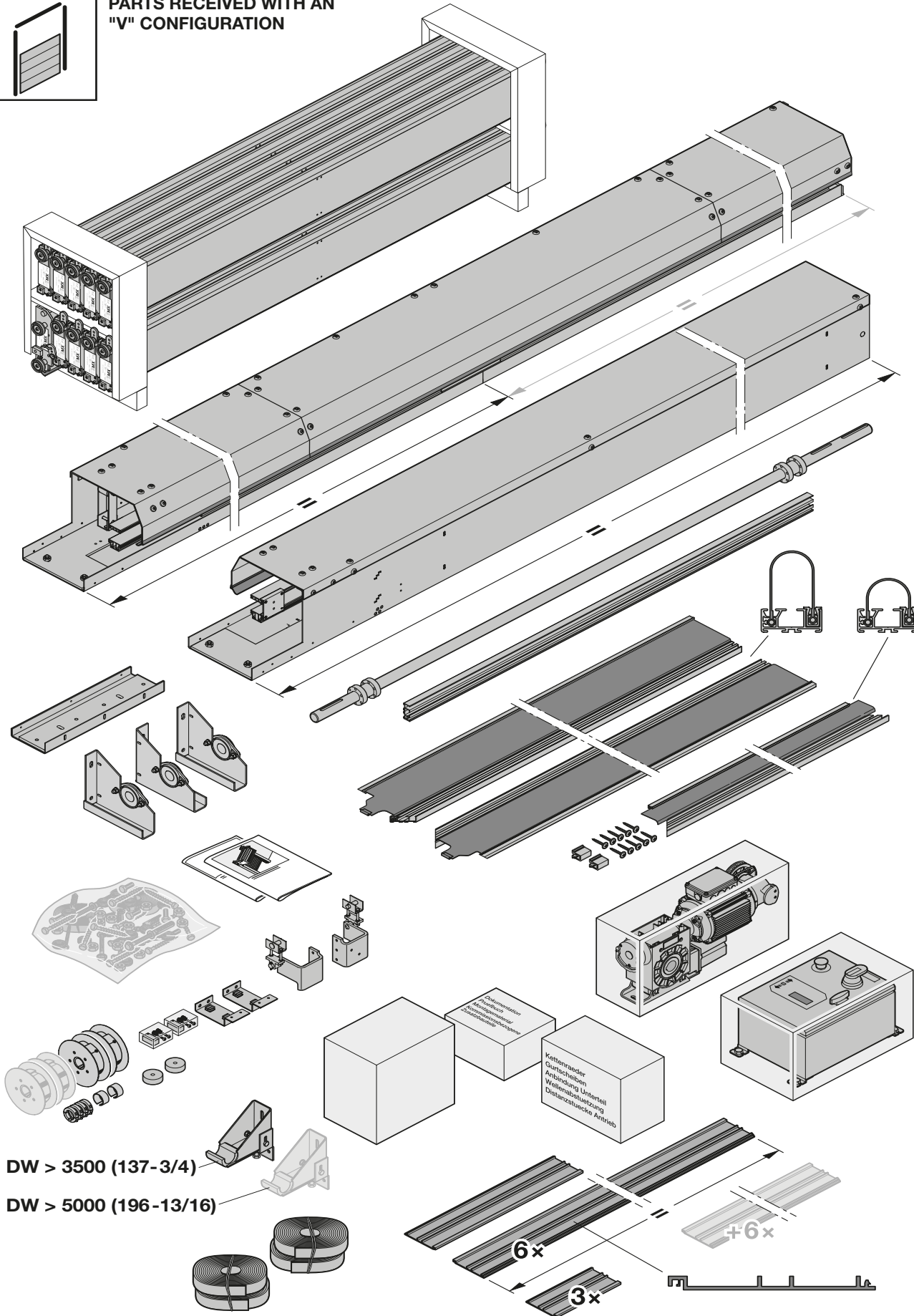

1 Important Installation Instructions

WARNING

- ▶ To reduce the risk of severe injury or death
- 1. **READ AND FOLLOW ALL INSTALLATION INSTRUCTIONS**
- 2. Install only on a properly operating and balanced door. A door that is operating improperly could cause severe injury. Have qualified service personnel make repairs to cables, spring, assemblies, and other hardware before installing the operator.
- 3. Remove all pull ropes and remove, or make inoperative, all locks (unless mechanically and/or electrically interlocked to the power unit) connected to the door before installing the operator.
- 4. A commercial/industrial door operator that has exposed moving parts capable of causing injury to persons or employs a motor deemed indirectly accessible by UL325 10.6 by virtue of its location above the floor shall include:
 - Install the door operator at least 2.44 m (8 ft) or more above the floor;
or
 - if the operator must be installed less than 2.44 m (8 ft) above the floor, then exposed moving moving parts must be protected by covers or guarding, provided by the manufacturer;
or
 - both (a) and (b)
- 5. Do not connect the door operator to the source of power until instructed to do so.
- 6. Locate the control station: (a) within sight of the door, and (b) at a minimum height of 1.53 m (5 ft) above floors, landings, steps, or any other adjacent walking surface and (c) away from all moving parts of the door.
- 7. Ensure that the track attached Entrapment Warning Label is visible.
- 8. For products having a manual release, instruct the end user on the operator of the manual release.

Contents

- 1 About These Instructions..... 6**
- 1.1 Further applicable documents..... 6
- 1.2 Warnings used..... 6
- 1.3 Symbols Used 7
- 1.4 Abbreviations Used 7
- 2  Safety Instructions..... 7**
- 2.1 Intended use..... 8
- 2.2 Qualification of personnel..... 8
- 2.3 Standards and regulations 8
- 2.4 General safety instructions..... 8
- 2.5 Safety instructions for operation 8
- 2.6 Safety instructions for maintenance and troubleshooting..... 8
- 3 Fitting..... 9**
- 4 Putting into Service 9**
- 4.1 Setting the End-of-travel Positions 9
- 4.2 Test run..... 10
- 5 Operation..... 10**
- 5.1 Instructed personnel..... 10
- 5.2 Normal wear 10
- 5.3 Emergency-OFF 10
- 6 Inspection and Maintenance 10**
- 6.1 Maintenance intervals..... 11
- 6.2 Wearing parts 11
- 7 Control..... 11**
- 8 Malfunctions and Troubleshooting 12**
- 9 Cleaning and Care 12**
- 10 Extension and Conversion..... 12**
- 11 Dismantling and Disposal..... 12**



- 13

Dear Customer,
We are delighted that you have decided to choose a high-quality product from our company.

1 About These Instructions

These instructions are divided into a text section and an illustrated section. The illustrated section can be found after the text section.

These instructions are **original instructions** as outlined in the EC Directive 2006/42/EC. Read through all of the instructions carefully: they contain important information about the product. Pay attention to and follow the instructions provided, particularly the safety instructions and warnings.

Please keep these instructions in a safe place and make sure that they are available to all users at all times.

The manufacturer is not liable for any damage caused as a result of non-compliance with the operating instructions and the information contained therein or due to non-customary use of the industrial door.





Competent operation and proper maintenance influence the performance and availability of your industrial door to a considerable degree. Operating errors and inadequate maintenance lead to avoidable failures. Only competent operation and proper maintenance will guarantee satisfactory, long-term operational safety.

Our customer service department will be happy to assist you. Please contact them if you have any questions after working through these operating instructions.

1.1 Further applicable documents









Depending on the ordered accessories, the delivery includes further instructions, e.g. instructions on how to control the door. Also read these instructions carefully and thoroughly. Pay attention to and follow the instructions provided herein, particularly the safety instructions and warnings.



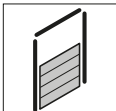

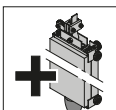
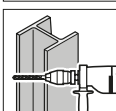
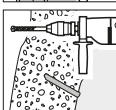
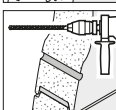

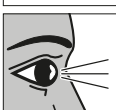
1.2 Warnings used

	The general warning symbol indicates a danger that can lead to injury or death . In the text, the general warning symbol will be used in connection with the caution levels described below. In the illustrated Section, an additional instruction refers back to the explanation in the text.
 DANGER	Indicates a danger that leads directly to death or serious injuries.
 WARNING	Indicates a danger that can lead to death or serious injuries.
 CAUTION	Indicates a danger that can lead to minor or moderate injuries.
ATTENTION	Indicates a danger that can lead to damage or destruction of the product.

Dissemination as well as duplication of this document and the use and communication of its content are prohibited unless explicitly permitted. Noncompliance will result in damage compensation obligations. All rights reserved in the event of patent, utility model or design model registration.

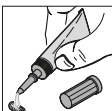
1.3 Symbols Used

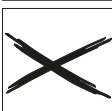
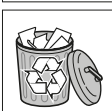
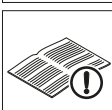
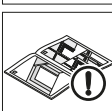
	Important advice to prevent injury to persons or damage to property
	Warning of dangerous electrical voltage
	Track application H
	Track application V
	Tighten the screws firmly
	Tighten the screws by hand
	Optional components
	Drilling in steel
	Drilling in concrete
	Drilling in insulated wall
	Remove residue
	Inspect
	Danger of crushing
	Risk of shearing

	Risk of impact
	Risk of trapping during door travel
	Grease
	Thread lock
	Correct arrangement or activity
	Non-permissible arrangement or activity
	Remove and dispose of component or packaging
	See text section
	See illustrated section
	See separate Fitting Instructions for the control or for the additional electrical control elements

1.4 Abbreviations Used

EN	European Standard
FFL	Top edge of finished floor line
DW	Door opening width
DH	Door opening height
Units	mm and (inches)
	NM and (Ft-Lbs)
	mm ² and (FT ²)

2  Safety Instructions

When used properly and for the intended purpose, industrial doors are reliable and safe to operate. Nevertheless, when used incorrectly or for purposes other than those intended, they can pose a risk. We therefore expressly draw your attention to the safety instructions contained in the individual chapters.

2.1 Intended use

Industrial doors are used to close passage openings, to safely shut off rooms, to make machines safe and secure, to save energy costs, to improve the room air conditions and to accelerate the flow of materials.

Intended use also includes paying attention to these instructions and observing inspection and maintenance conditions.

Any other or further use is regarded as non-intended use. The manufacturer / supplier is not liable for any damage resulting from this. The risk is borne solely by the user.

2.2 Qualification of personnel

Only qualified and instructed personnel may fit, operate and maintain the industrial door.

Before commencing work the assigned personnel must read these instructions, particularly chapter 2.

For safety reasons, specify distinct responsibilities for operation, maintenance and repairs to ensure that there are no unclear assignments.

2.3 Standards and regulations

At the least, observe the following European standards and directives, as well as country-specific safety requirements, standards and regulations.

Standards

ANSI/DASMA 108-2017 Standard Method for Testing Sectional Garage Doors, Rolling Doors and Flexible Doors: Determination of Structural Performance Under Uniform Static Air Pressure Difference

UL325 Standar for safety: Door, drape, gate, louver, and window operators and systems

Electrical Regulations

NFPA70 Electrical installations with electronic equipment
Note that local regulations must be considered but are not listed

Accident prevention regulations

NFPA70 Electrical installations and equipment
OSHA1910 Technical Rules for Workplaces

2.4 General safety instructions

- In addition, also observe the generally applicable statutory regulations and other binding regulations for accident prevention and environmental protection, country-specific regulations, and the recognised specialist technical rules for safe and competent working must be observed. Before beginning work, instruct personnel in accordance with these rules and regulations.
- Always keep these instructions ready to hand at the location where the industrial door is used.

- Without the supplier's prior approval, do not carry out any modification, attachment or conversion work on the industrial door which might compromise safety.
- Do not make any modifications to the software on programmable control systems.
- The location and operation of fire extinguishers must be indicated by appropriate information signs. Observe the statutory fire alarm and fire-fighting regulations.
- All work on the industrial door (such as maintenance, cleaning work and inspections) may only be performed during an operational shutdown.
- Only qualified electricians may perform work on the mains supply.
- Before undertaking any work, disconnect the system from the mains supply and ensure that it cannot be inadvertently turned on. If available, deactivate the emergency opening lever.

2.5 Safety instructions for operation

- Before actuating the door, make sure that no persons or objects are located in the door's area of travel.
- Do not reach into the guide or guide area while the door is in operation.
- Only actuate the industrial door if it is safe and functional. All protective devices and safety-related devices (e.g. detachable protective devices and emergency-OFF devices) must be present and functioning.
- Do not modify or put the safety devices out of operation.

2.6 Safety instructions for maintenance and troubleshooting

- Perform inspection and maintenance work as described in chapter 6. Comply with the maintenance intervals and note the information on the replacement of parts / partial equipment.
- Maintenance and troubleshooting may only be carried out by specialist personnel.
- Only use spare parts that comply with the technical requirements specified by the manufacturer. This is always guaranteed when original spare parts are used.
- Only carry out welding, burning and grinding work on the industrial door if this work has been expressly approved. For example, there may be a risk of fire and explosion! Prior to welding, burning and grinding, remove dust and combustible materials from the industrial door and its surroundings and ensure that there is adequate ventilation (risk of explosion)!
- Before disassembling the operator, fix the shaft on the operator side (e.g. with a forklift).

3 Fitting

⚠ DANGER

Mains voltage!
Contact with the mains voltage presents the danger of a deadly electric shock. For that reason, observe the following warnings under all circumstances:

- ▶ Only qualified electricians may perform work on the mains supply.
- ▶ Make sure that the on-site electrical installation complies with the applicable safety requirements.
- ▶ Ensure that the national regulations governing the operation of electrical equipment are complied with.
- ▶ Install the control unit for the industrial door operator within sight of the door.
- ▶ Before undertaking any electrical work, disconnect the system from the mains supply and ensure that it cannot be inadvertently turned on.

ATTENTION

External voltage
External voltage on the connecting terminals of the control will destroy the electronics.

- ▶ Do not apply any external voltage (e.g. mains voltage) to the connecting terminals of the control unit.

ATTENTION

Pull forces on electric cables
Pull forces on electric cables will destroy the electronics.

- ▶ Never pull on the connecting leads of the electrical components.

NOTE:

The included fixing material is approved for the following subsurfaces.

Concrete screws:	Fitting subsurface cracked concrete C20 / 25, uncracked concrete C20 / 25 and brickwork.
Long shaft plug:	Fitting subsurface concrete C12 / 15, gas concrete, sand-lime solid brick and solid brick.
Metric screws:	Fitting subsurface steel, a suitable material thickness and strength must be observed.

For deviating subsurfaces, suitable fixing material must be selected (not in scope of delivery).

NOTE:

Also follow the other enclosed instructions for installation of electrical connections and fitting additional electrical control elements.

To fit the door:

1. Take precautionary measures to make the site safe.
2. Check the on-site fitting conditions for the door (check measurements).
3. Check the quality of the structure for its strength.

4. Choose suitable fastenings.
5. Unpack the door and check for damage.
6. If delivered by a freight forwarder: Report any damage immediately.
7. Check that the delivery is complete.
8. Dispose of the packaging material.
9. Fit the door as shown in the illustrated section.



4 Putting into Service

⚠ WARNING

Faulty door
A faulty door may injure persons or damage objects.

- ▶ Only put the door into service if it is in perfect condition.

⚠ WARNING

Door movements
Door travel may injure persons or damage objects.

- ▶ Make sure that no persons or objects are in the door's closing area during operation.
- ▶ Never use the door to lift objects or persons.
- ▶ Never reach into the guide, guide are, chain, toothed wheel or return pulley during door operation.

4.1 Setting the End-of-travel Positions

The end-of-travel positions of the door are set on the control cabinet.

NOTE:

Please follow the instructions supplied with the operator and control unit.

4.1.1 CLOSE end-of-travel position

ATTENTION

Exceeding the CLOSE end-of-travel position
If the door travels beyond the *Close* end-of-travel position, the bottom profile may be compressed. This could disrupt the diode deactivation of the light grille.

- ▶ Never exceed the *CLOSE* end-of-travel position.

- ▶ Set the *CLOSE* end-of-travel position so that the bottom profile makes full contact with the floor. If the guide is supported or the floor uneven, select the bottom edge of the side element as the end-of-travel position.

4.1.2 OPEN end-of-travel position





ATTENTION
<p>Exceeding the OPEN end-of-travel position</p> <p>If the door travels beyond the <i>OPEN</i> end-of-travel position, there is a risk of the door curtain slipping out of the side guides and sustaining damage.</p> <ul style="list-style-type: none"> ▶ Never exceed the <i>OPEN</i> end-of-travel position.

- ▶ Set the *OPEN* end-of-travel position so that the lower edge of the bottom profile corresponds to the dimension for the door height.

4.2 Test run

1. After fitting the door, test the functional safety according to the acceptance / handing-over report.
2. Verify in the test log book (dated and signed) that a test run has been successfully completed.
3. Hand the entire door documentation over to the owner or operator of the door.

5 Operation

 WARNING	
  	<p>Door movements</p> <p>Door travel may injure persons or damage objects.</p> <ul style="list-style-type: none"> ▶ Make sure that no persons or objects are in the door's closing area during operation. ▶ Make sure that the door has opened completely before driving in or out! Never drive or walk through doorways unless the door has reached the <i>OPEN</i> end-of-travel position. ▶ Whenever driving in or out of the opening, always check that the door curtain has travelled up far enough to provide the necessary passage height. ▶ Never use the door to lift objects or persons. ▶ Do not reach into the guide or guide area while the door is in operation.

ATTENTION
<p>Emergency operation devices</p> <p>Too frequent use of the emergency operation devices may damage them. This will also void the warranty for the door.</p> <ul style="list-style-type: none"> ▶ Only use the emergency operation devices in the case of a power failure or during repair work.

ATTENTION
<p>Aggressive media, wind and heat</p> <p>Aggressive media, wind and heat may damage the door.</p> <ul style="list-style-type: none"> ▶ Protect the door from aggressive media: <ul style="list-style-type: none"> – Saltpeter from stone or concrete – Cement – Plaster – Acids – Alkali – Road salt – Aggressive paints or sealants – Aggressive sealants ▶ Do not open or close the door if it is windy (no outside door). ▶ Avoid temperatures greater than 50°C near the door.

5.1 Instructed personnel

The door may only be operated by persons who have been instructed in its proper use. A person is considered to be instructed (EN 12453), if he / she has received instruction as to how to operate the door safely and has received permission from the owner to use the door system.

5.2 Normal wear

The design of the door represents state-of-the-art technology. Pressure marks and abrasive wear are design-related and cannot be avoided.





5.3 Emergency-OFF



- ▶ In emergency situations, de-energise the control by actuating the main switch, pulling the mains plug or, if available, actuating the red **emergency-OFF** button.

6 Inspection and Maintenance

 WARNING
<p>Unmaintained doors</p> <p>There is a danger of injury and damage if the door is not regularly maintained. This will also void the warranty.</p> <ul style="list-style-type: none"> ▶ Inspect and maintain the door regularly as described in these instructions or entrust this work to the manufacturer's service department.

 DANGER
<p>Mains voltage!</p> <p>Contact with the mains voltage presents the danger of a deadly electric shock.</p> <ul style="list-style-type: none"> ▶ Before undertaking any electrical work, disconnect the system from the mains supply and ensure that it cannot be inadvertently turned on.

 WARNING	
	<p>Door movements There is a danger of injury and damage if the door is actuated during inspection or maintenance work.</p> <ul style="list-style-type: none"> ▶ Before undertaking any work, disconnect the system from the mains supply and ensure that it cannot be inadvertently turned on. ▶ If available, deactivate the emergency opening lever / handle.
	
	

 WARNING	
	<p>Falling parts During dismantling, parts may fall and injure persons or damage property.</p> <p>Cladding (option)</p> <ul style="list-style-type: none"> ▶ Fix the cladding (e.g. with a forklift) before dismantling. <p>Shaft</p> <ul style="list-style-type: none"> ▶ Fix the shaft (e.g. with a forklift) before dismantling the operator.

Only inspect and maintain the door yourself if you are a qualified specialist (competent person according to EN 12635). In other words, you have the suitable training, specialist knowledge and practical experience to allow you to carry out inspection and maintenance correctly and safely. Observe all the applicable regulations governing work safety.

In general, we recommend entrusting maintenance / inspection to the manufacturer’s service department.

The high-speed door is low-maintenance. In normal operating conditions, all the bearings, including the gears, are lubricated for life and are maintenance-free.

6.1 Maintenance intervals

In compliance with the guidelines for power-operated windows, doors and gates testing and maintenance of the door must be carried out once a year, and as far as possible at the same intervals.

Depending on the size of the door and the annual number of door cycles, we recommend the following maintenance intervals:

In the case of a high number of door cycles (> 50000 per year):

Servicing of the functional elements every six months:

- Electric operator and brake
- All screw connections
- Travel limit cut-off / creep speed switch-over
- Control / impulse generator

In the case of a smaller number of door cycles:

Annual servicing in conjunction with the stipulated test procedures.

- ▶ Check the function of the “D” devices (photocell / light grille) every six months.

ATTENTION	
	<p>1.080 ▶ Maintenance will be necessary, service counter expires soon</p>
F.080	▶ Malfunction, maintenance required
<p>NOTE: It is mandatory to replace the elements marked with (*) within the next 5,000 door cycles.</p>	

6.2 Wearing parts

If provided, the indicated maximum assumable cycles or door cycles apply to the following wearing parts:

Wearing parts	Cycles	Period
Operator SG 5040 TurboLux	1 000 000	2 years
Tubular drive (SC 1500 SEL 2.0, 60% ED) ¹⁾	1 000 000	2 years
Tubular drive (V 4020 Logistic) ¹⁾	1 500 000	2 years
Tubular drive (SC 1500 SEL MP / Freezer) ¹⁾	2 500 000	2 years
Operator (60% ON time)	500 000	2 years
Brake	250 000	
Radio crash switch battery	- / -	2 years
Energy chain with cable	250 000	2 years
Springs	100 000	2 years
Fabric belts	100 000	2 years
Flat belt, door leaf counter weight	500 000	2 years
Rubber cord	100 000	2 years
Rollers	100 000	2 years
UPS battery	- / -	1.5 years
UPS battery (RW doors)	- / -	1 year
Hinges	100 000	2 years
Seals, sealing strips	150 000	2 years
Light grille, photocell	- / -	2 years

¹⁾ Compulsory replacement of the components in the above-mentioned Cycles

7 Control

The control system is manufactured individually for each door ordered. The respectively applicable wiring diagram is included in the operator instructions.

- ▶ Add the wiring diagram and software description to these instructions.

Each control cabinet has its own identification number.

- ▶ Always quote this number in the case of queries.

8 Malfunctions and Troubleshooting

In the case of malfunctions, contact the Customer Service.

Operator power

The operating voltage must be 230 V ± 5 % or 460 V ± 5 %. If the voltage deviates greatly from this, there may be problems with the operator power. Verify with factory.

9 Cleaning and Care

Use warm water together with a neutral, non-abrasive cleaning agent (household detergent, pH value 7, Isopropanol 99,9 %).

To clean the surface, use only a soft cloth or window leather. Rinse off any dirt and dust particles with clear water.

10 Extension and Conversion

WARNING

Unsuitable components

Unsuitable components could overload the door construction. This could lead to serious injury.

- ▶ Only use components approved by the manufacturer.

Only extend or convert this door system with the manufacturer's permission.

Carrying out any structural alterations to the product without the manufacturer's permission renders the warranty and product liability null and void.

11 Dismantling and Disposal

WARNING



Falling parts

During dismantling, parts may fall and injure persons or damage property

Cladding (option)

- ▶ Fix the cladding (e.g. with a forklift) before dismantling.

Shaft

- ▶ Fix the shaft (e.g. with a forklift) before dismantling the operator.

Only dismantle this door if you are qualified to do so. In other words, you have the suitable training, specialist knowledge and practical experience to allow you to dismantle the door correctly and safely.

Observe all the applicable regulations governing work safety when dismantling the door.

To dismantle and dispose of the door:

1. Open the door fully.
2. Carefully roll up the door manually (emergency manual operation).
3. Tape round the door curtain several times with strong adhesive tape (e.g. packing tape) to prevent it from unrolling.

4. Drive a forklift truck with suitable pallet or supporting frame underneath the shaft, so that the shaft rests on the pallet or supporting frame.
5. Release the fastenings securing the bearing and the operator.
6. Lift the shaft or top part together with the operator off the support brackets.

CAUTION

The operator may slide off the barrel journal

- ▶ When letting the shaft or top part down, take care to keep it level.
7. Dismantle the side guides or side elements and support brackets.
 8. Disassemble the door into component parts and dispose of them properly.

1

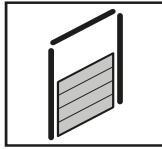
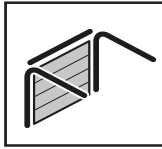

T30  
19  

#2  

Unpacking side tracks

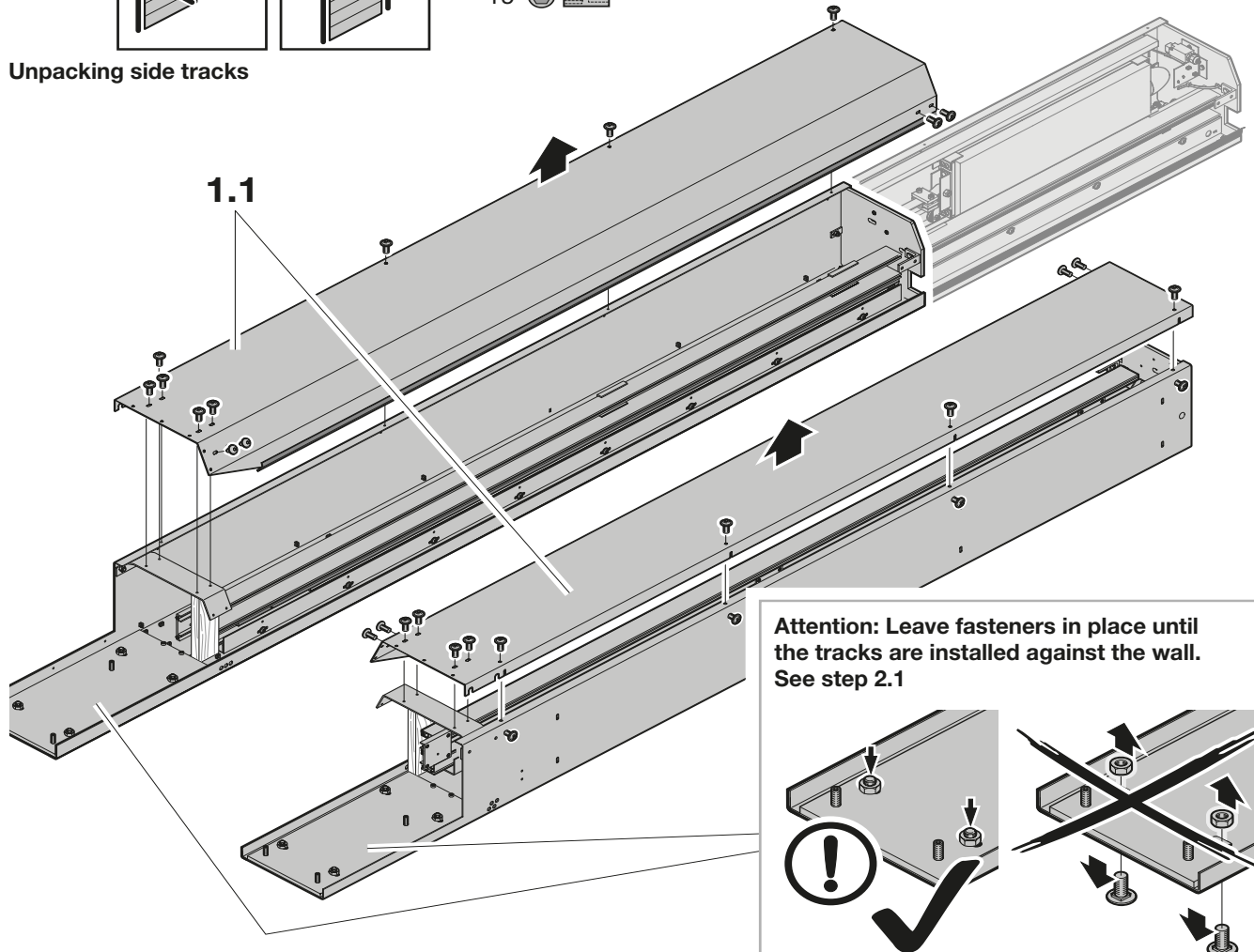

1.1 Attention: Keep all hardware for re-installation later.

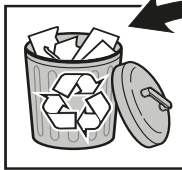

1

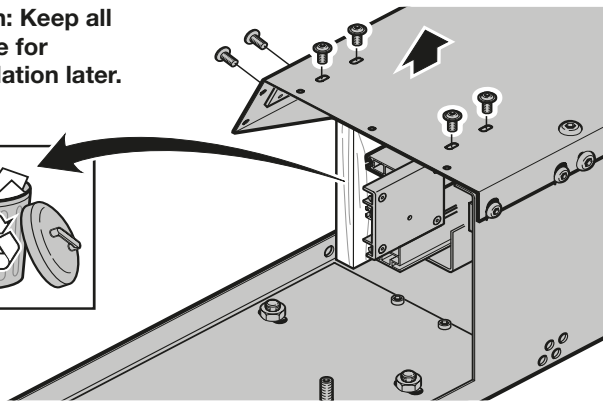

2

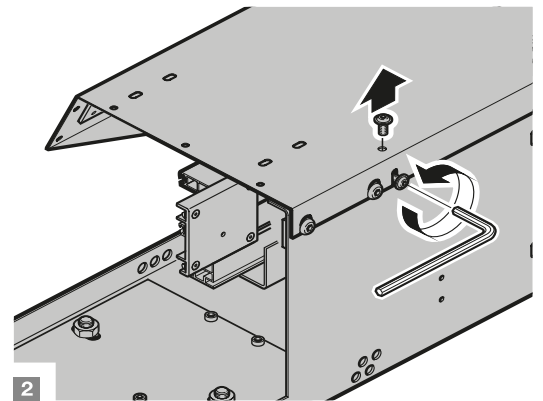

3

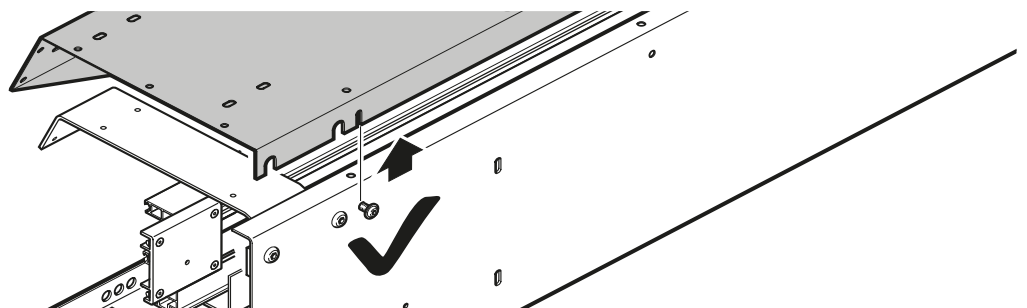

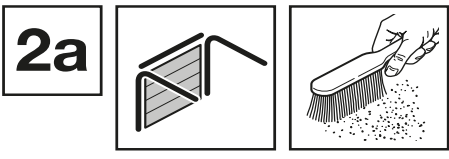
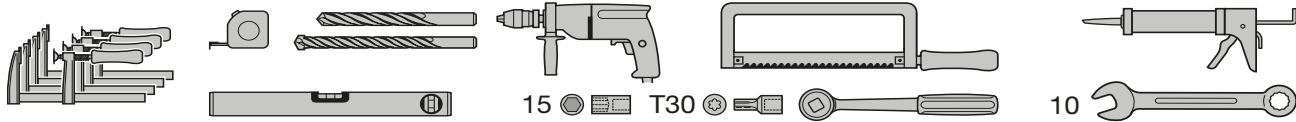

Attention: Tracks must be installed using CheckDim found on the yellow label inside of the tracks!

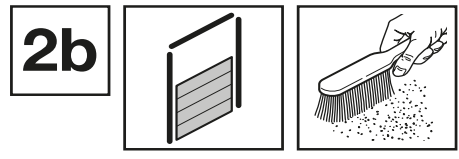

Installing side tracks "H" configuration

Installing side tracks "V" configuration

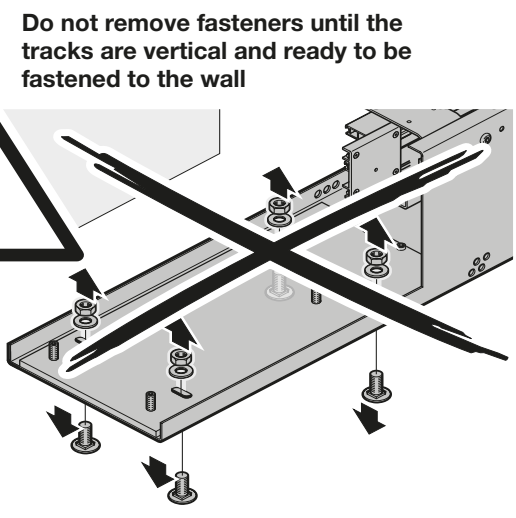
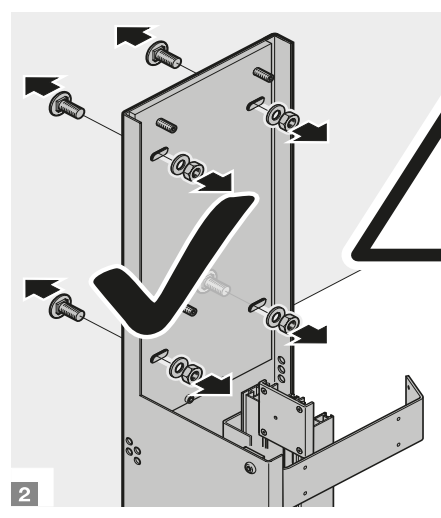
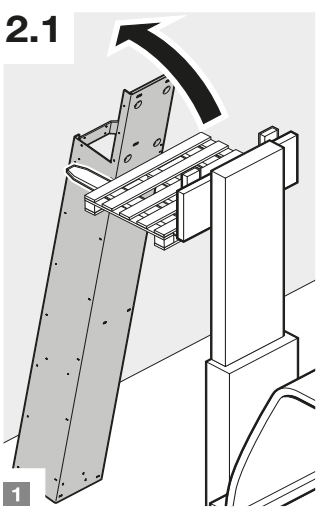
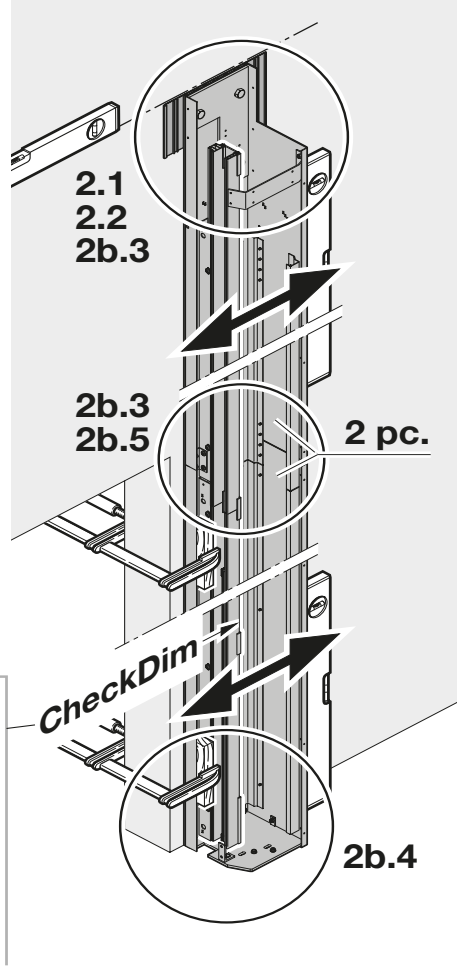
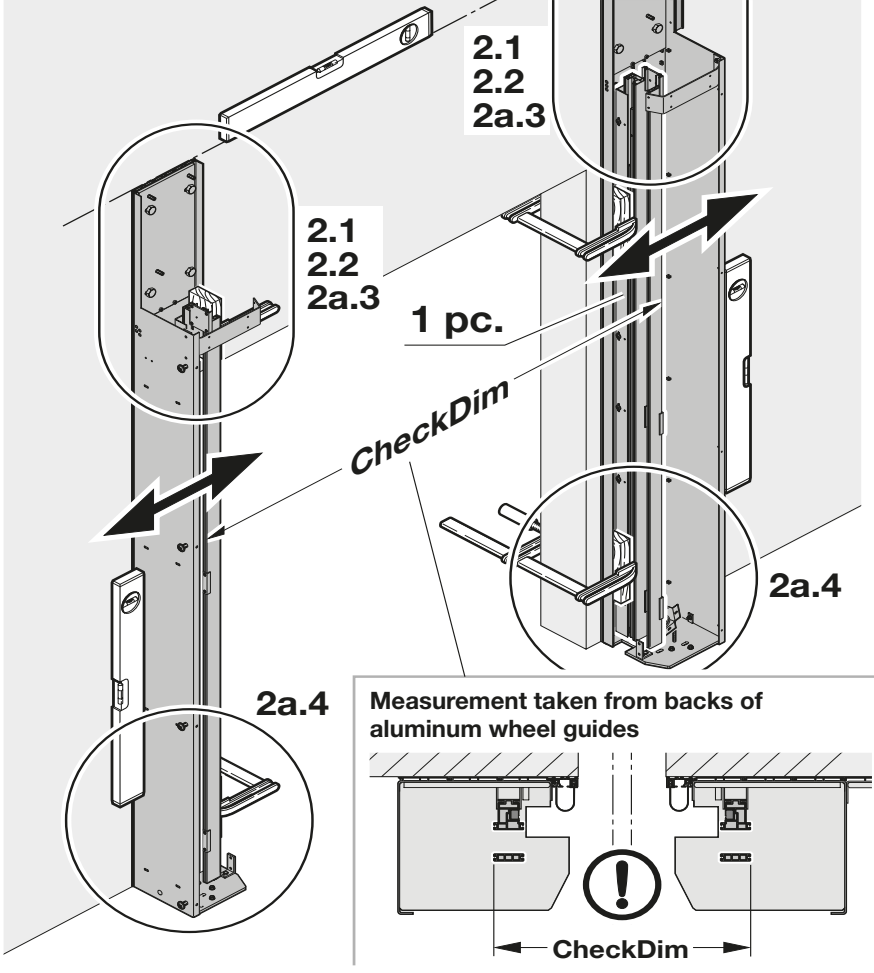

2.2

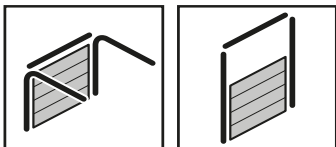

Installing thermal break

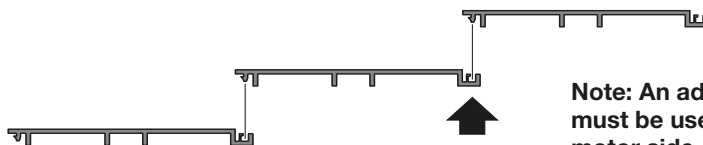

Note: An additional piece must be used for the motor side, and V door bearing supports

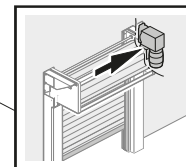
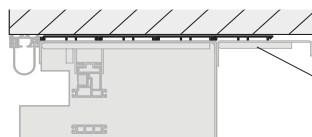
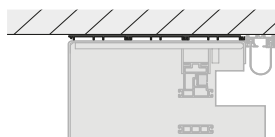

Use Caulk or construction adhesive (not included) to hold break material to track prior to fastening.

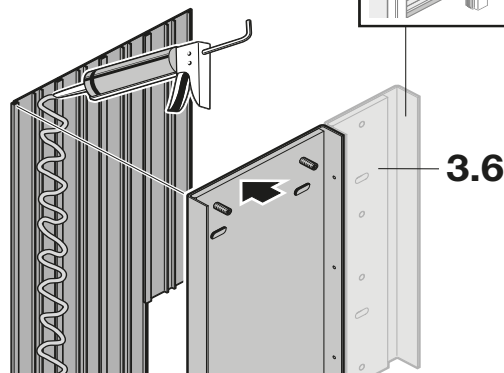
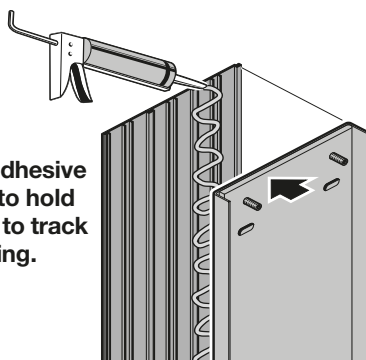

2a.3

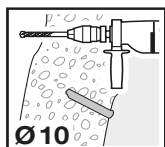
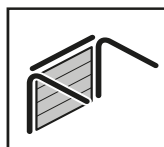

MM 12 x 90

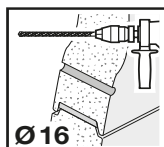
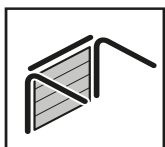

Ø16

Hardware by others

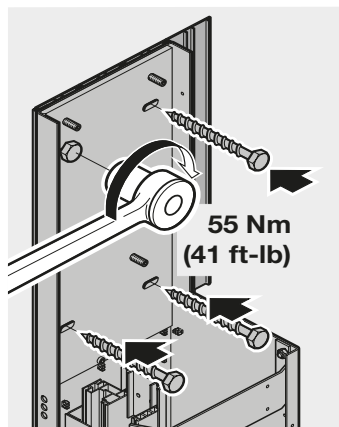

55 Nm
(41 ft-lb)

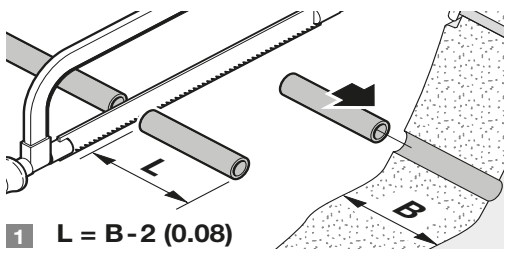

1 $L = B - 2 (0.08)$

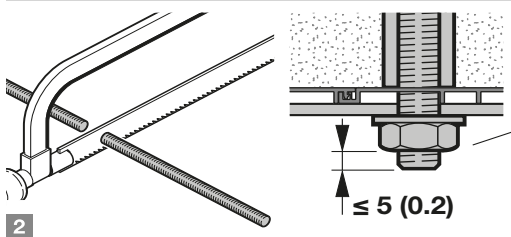

2

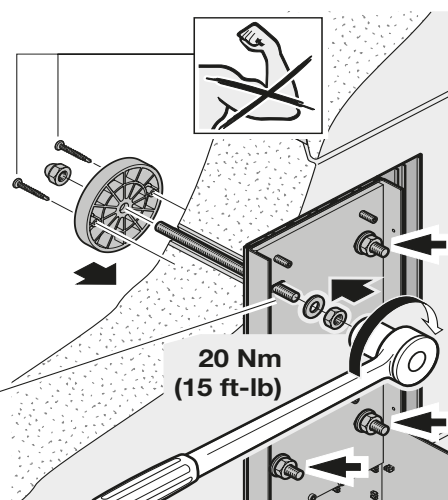

20 Nm
(15 ft-lb)

2a.4

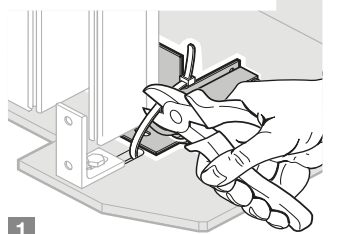

1

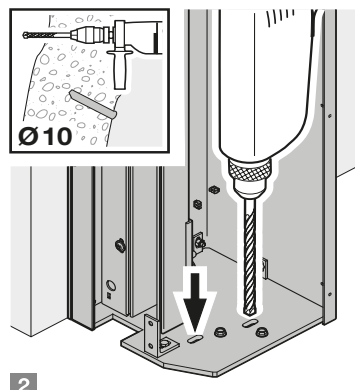
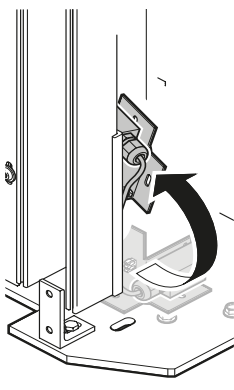

2

SXRL 10 x 60 FUS

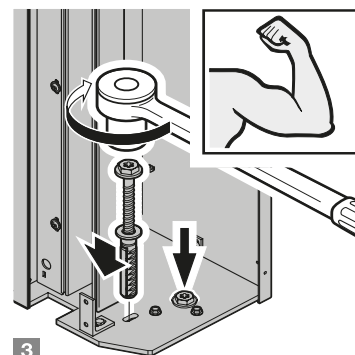

3

2b.3

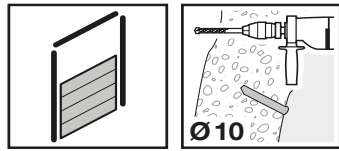
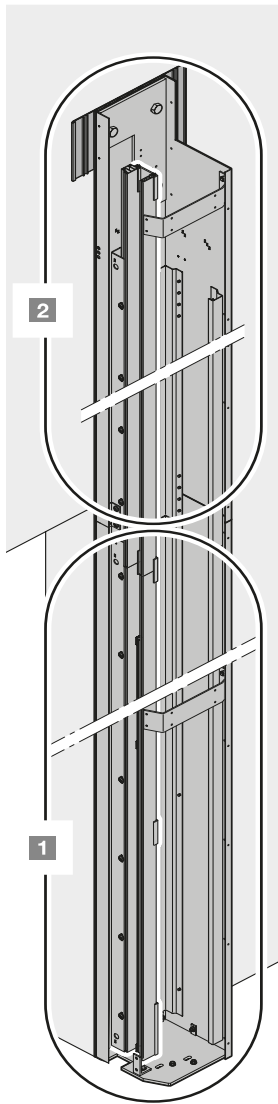

MM 12 x 90

Hardware by others

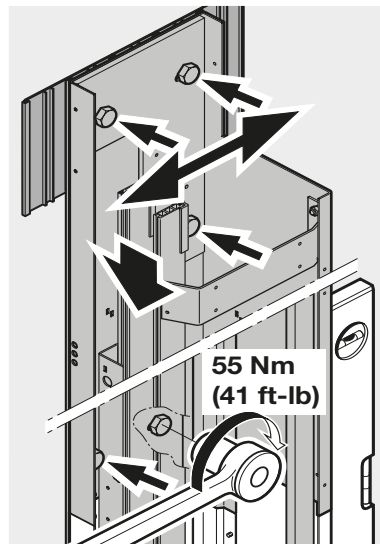
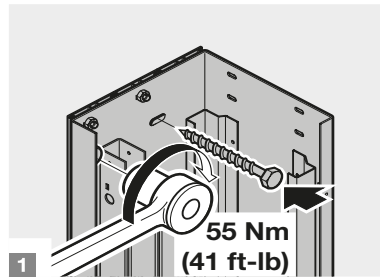

Make fine adjustments as needed for door width before fastening to wall

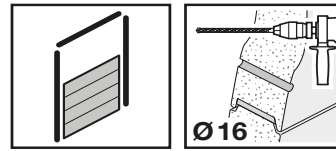

Hardware by others

$$L = B - 2 (0.08)$$

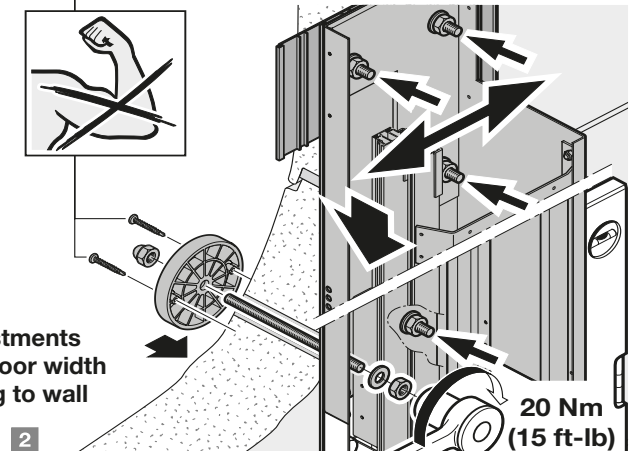
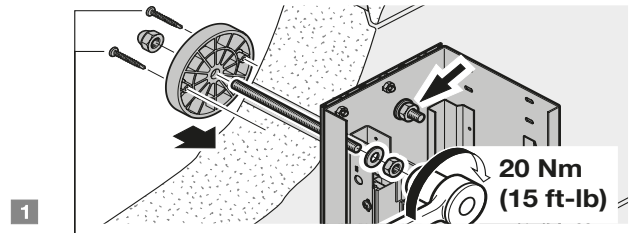
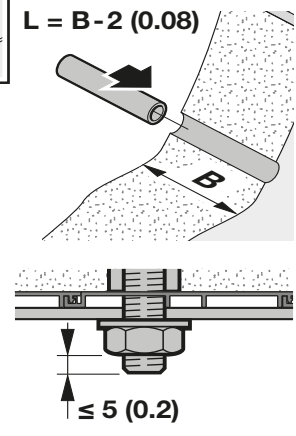
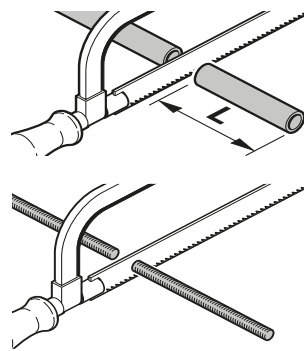

2b.4

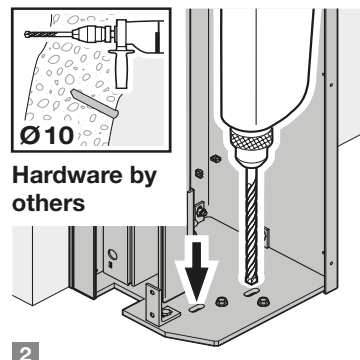
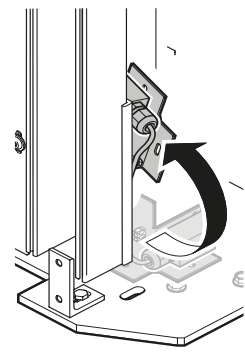
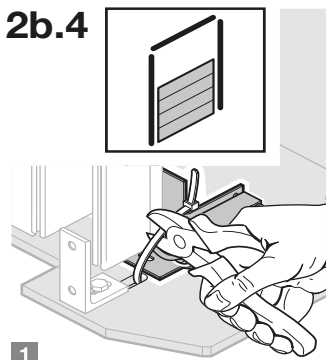

Hardware by others

SXRL 10 x 60 FUS

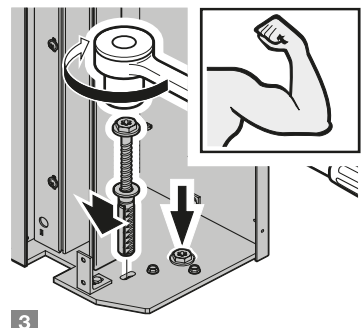

2b.5

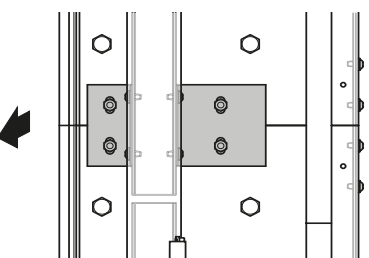
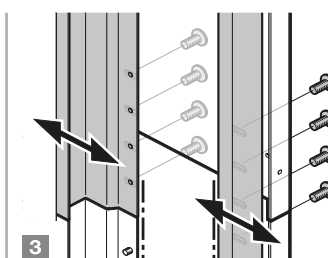
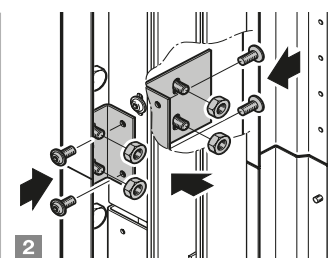
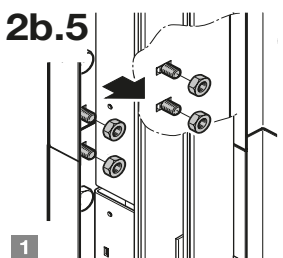

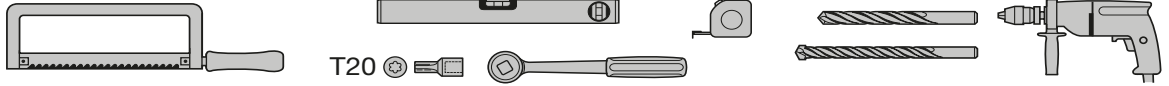

3a

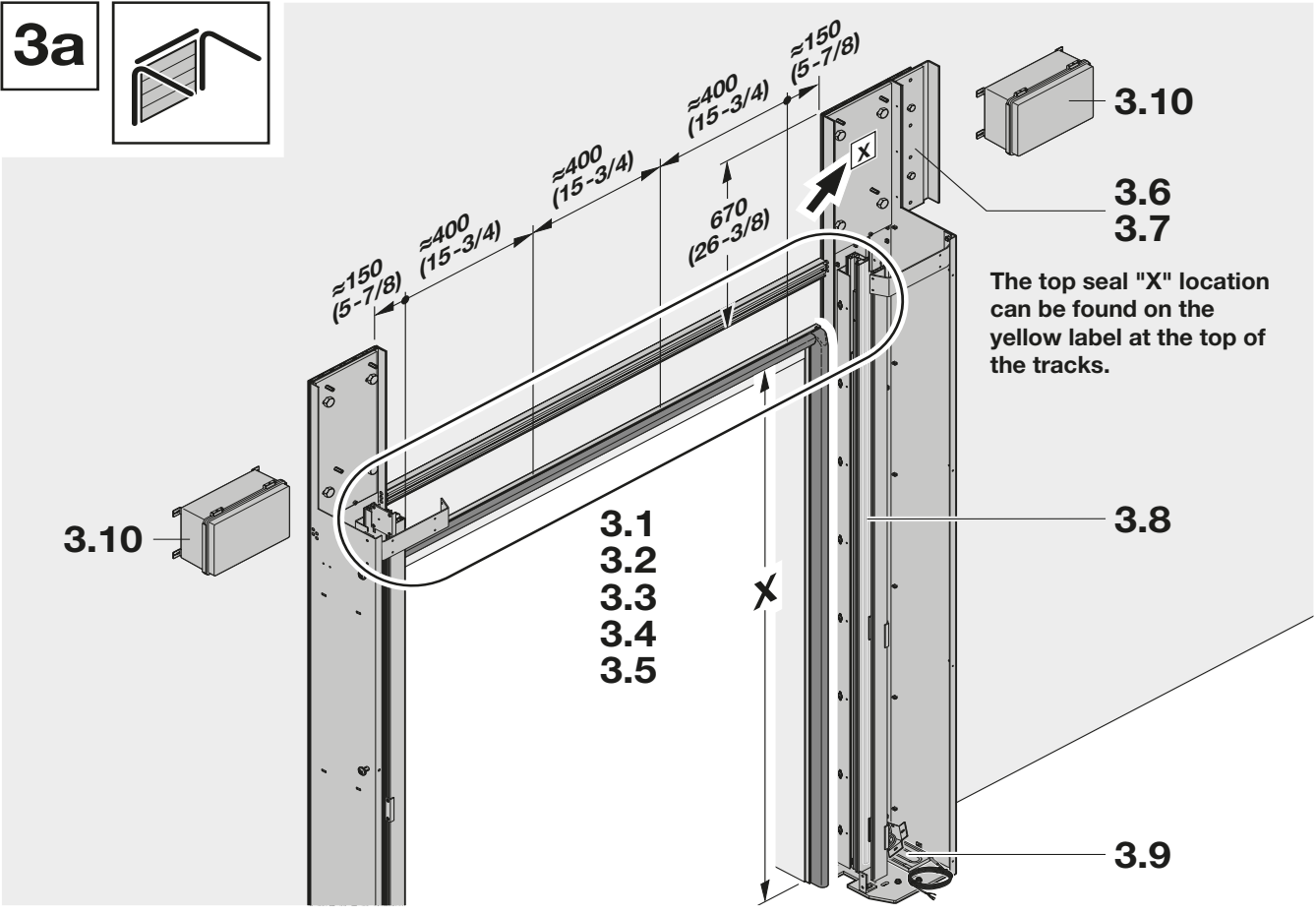
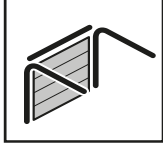

3b

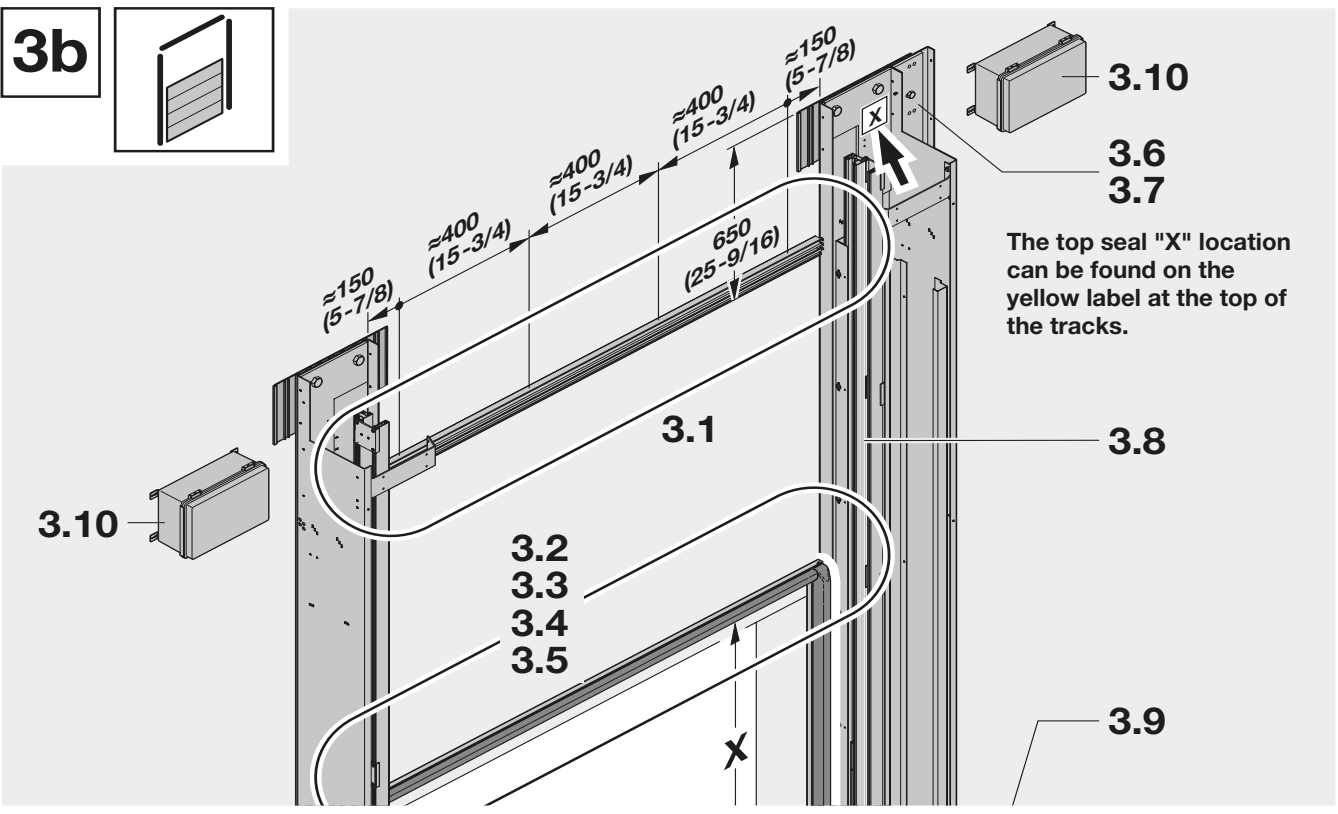
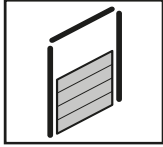

3.1

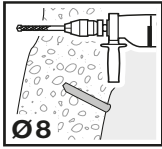

Hardware by others

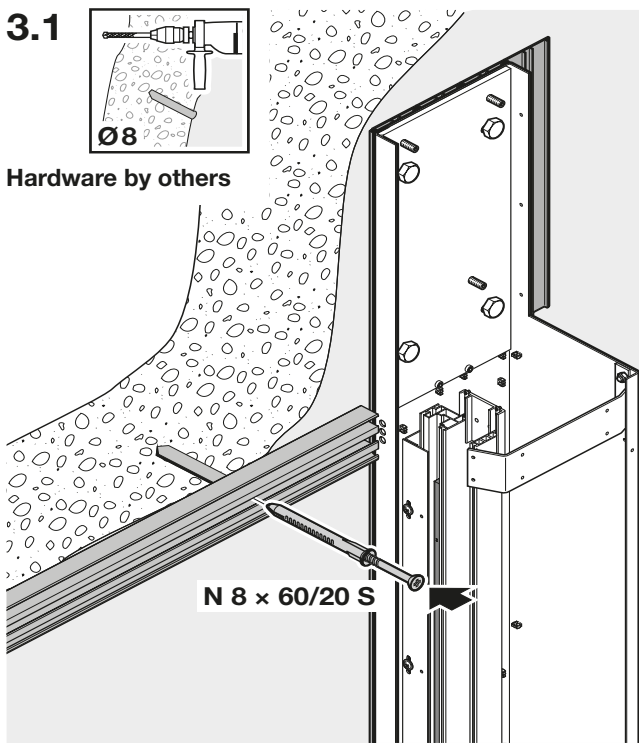

N 8 x 60/20 S

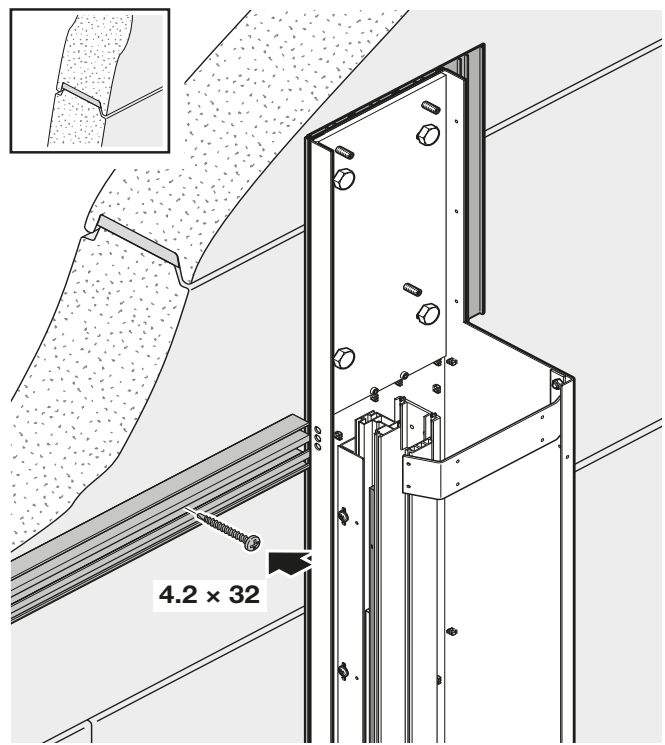
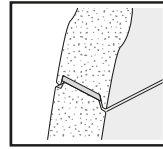

4.2 x 32

3.2

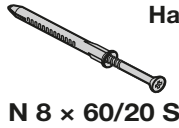
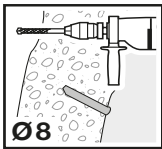

N 8 x 60/20 S

Hardware by others

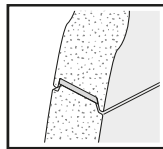

4.2 x 32

Attention: It is important that the top seal is positioned as outlined on the "X" dimension to ensure proper sealing

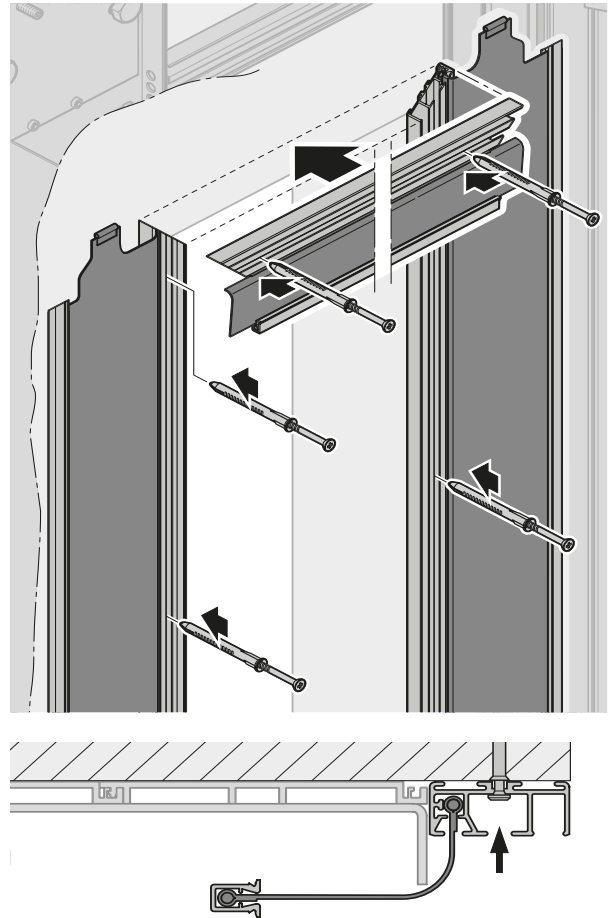
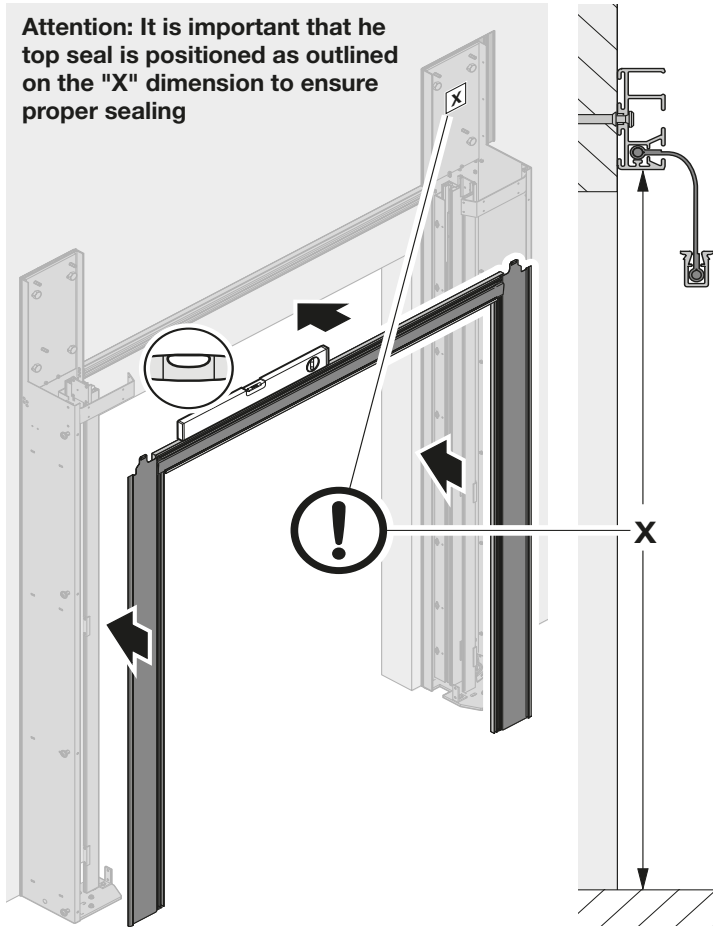

3.3 Installing perimeter heating

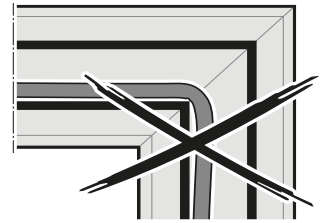
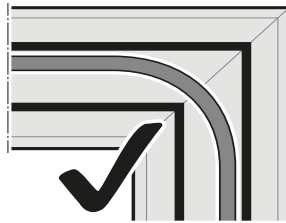
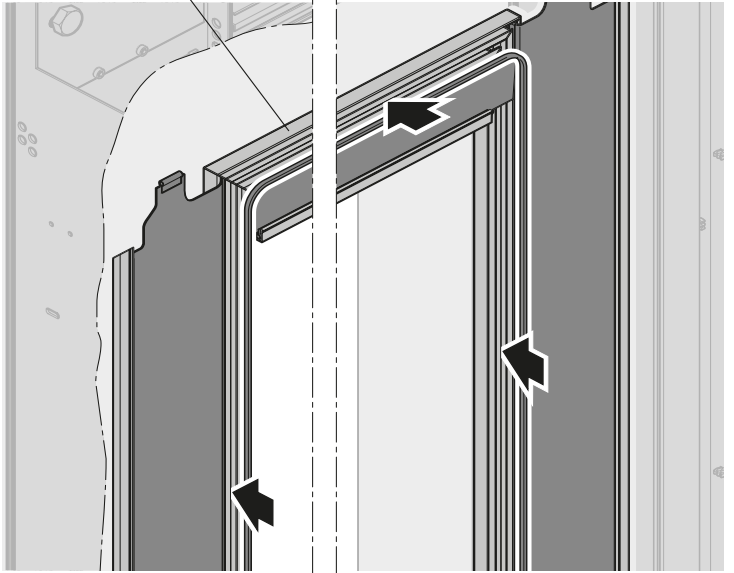
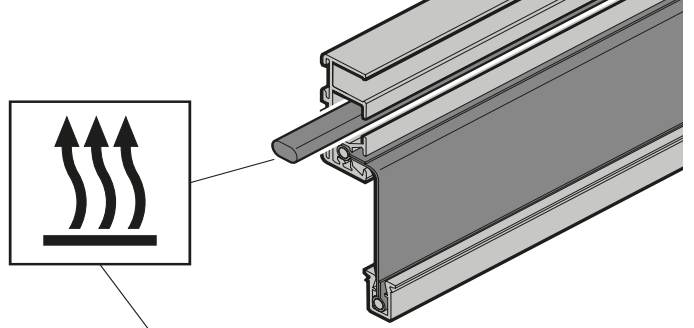
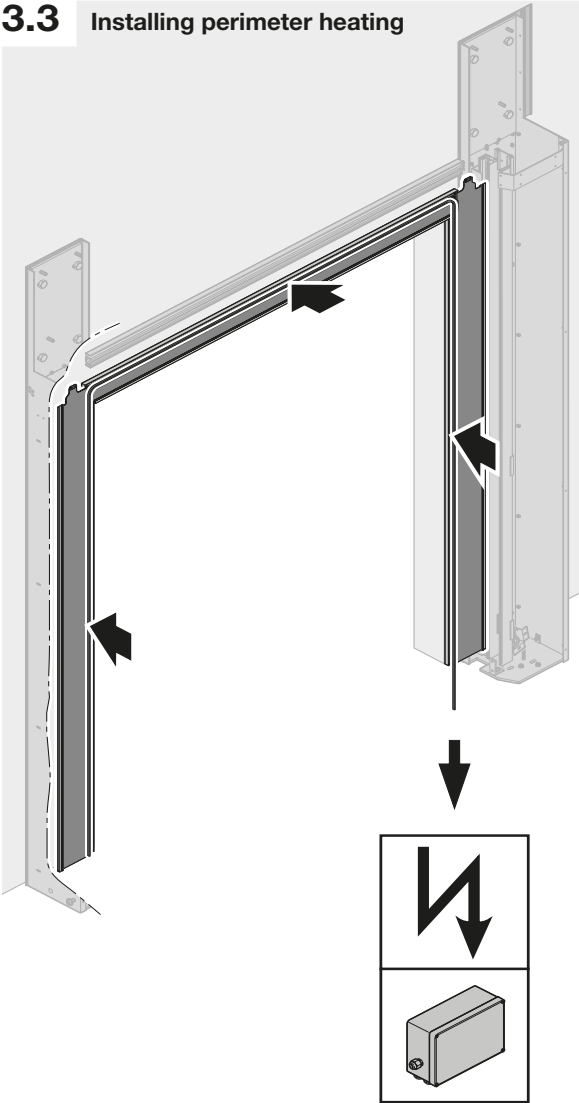

3.4

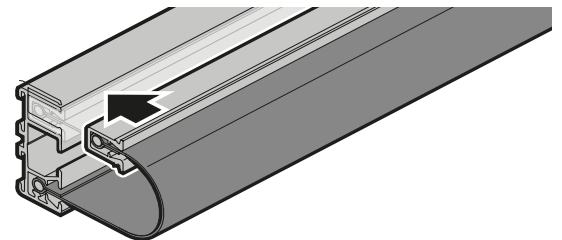
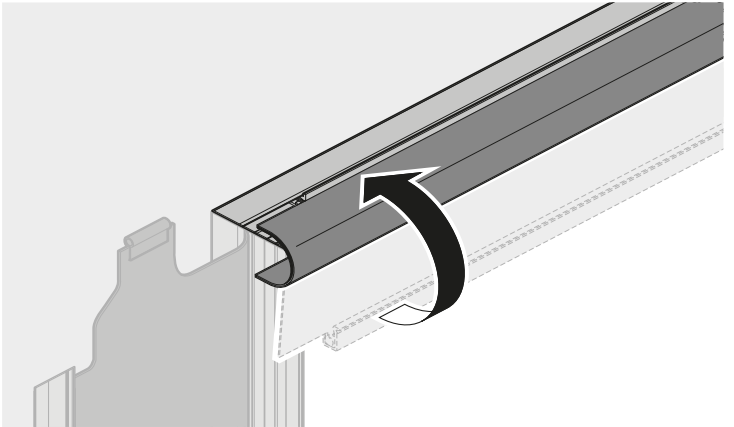
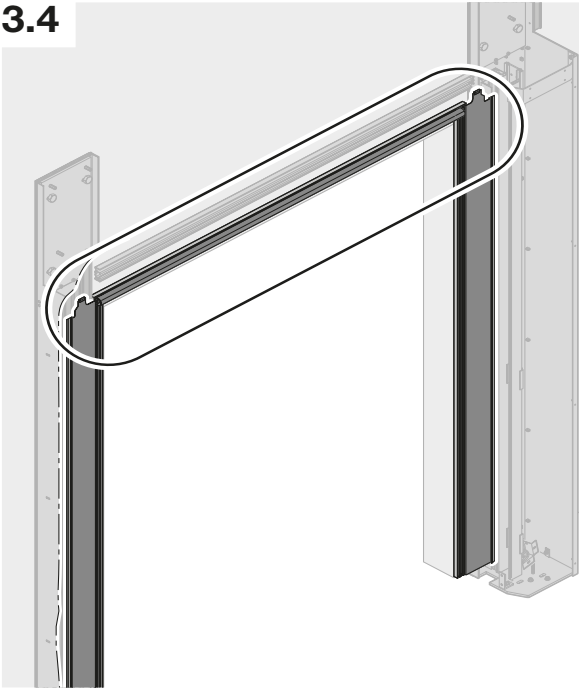

3.5 Install screws to secure perimeter seal

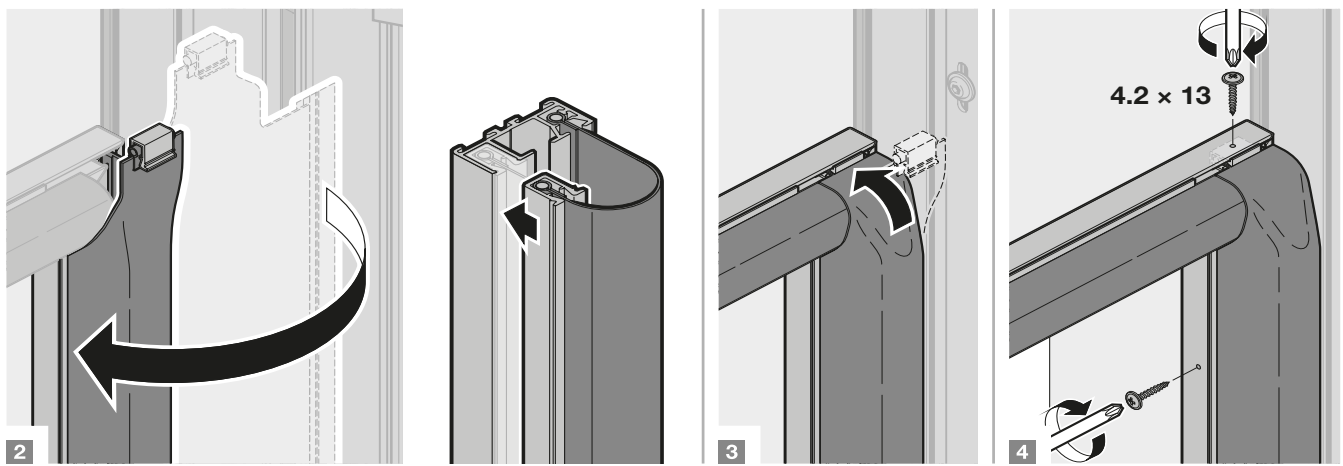
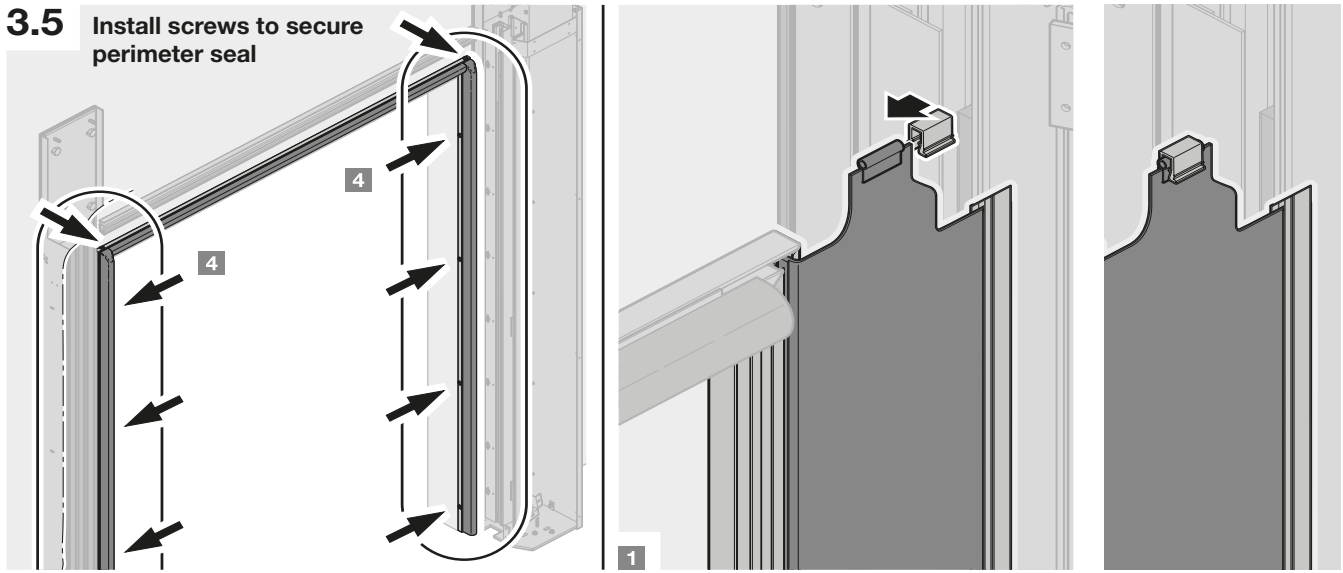

3.6 DIN7500 M6 x 12

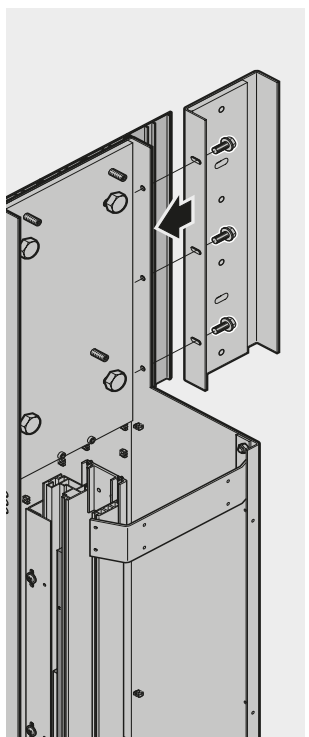

3.7

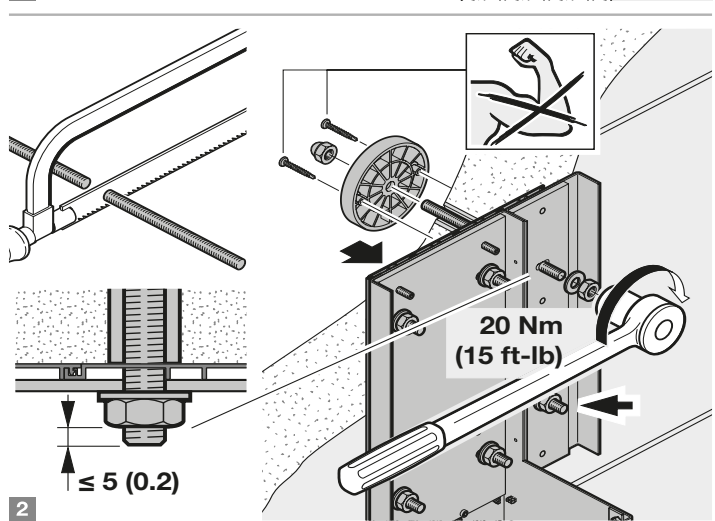
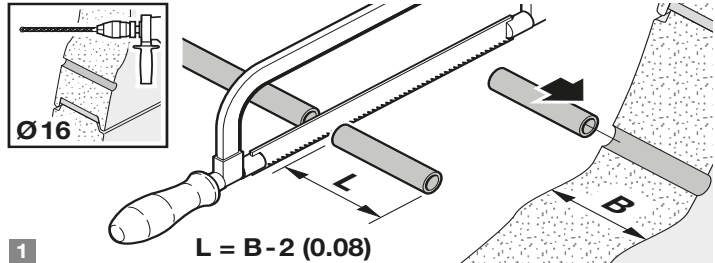
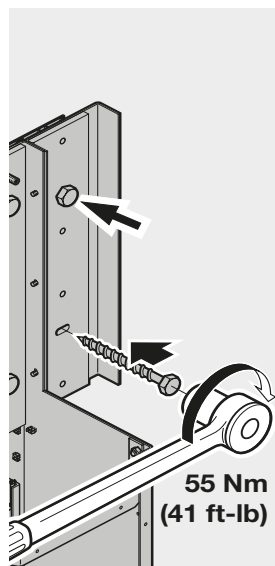
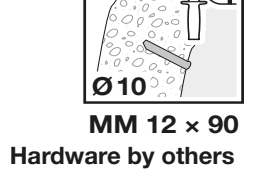

3.8 Guide heat tape through the aluminum channel as outlined.

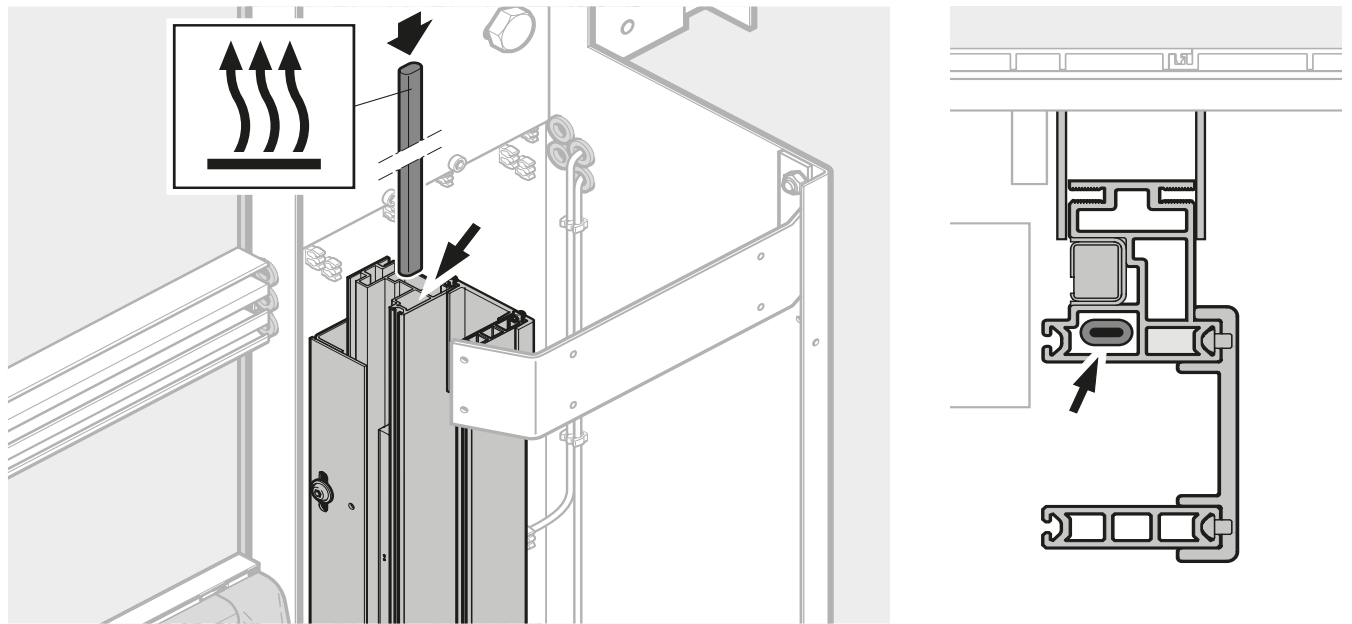

3.9

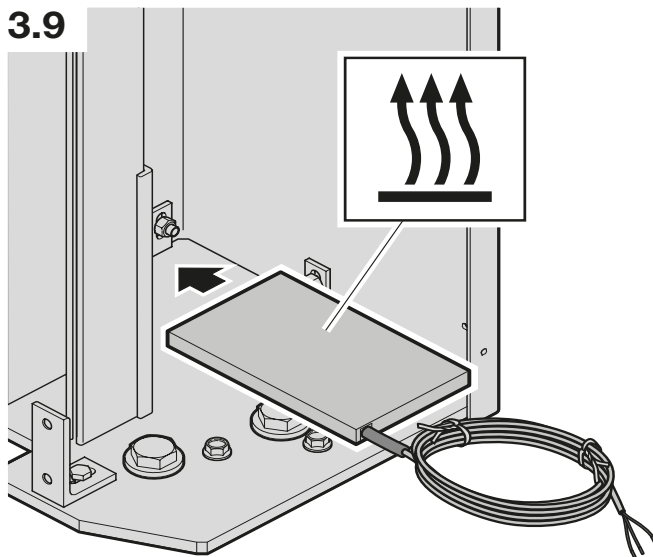

Route heater wire into track U-Profile.

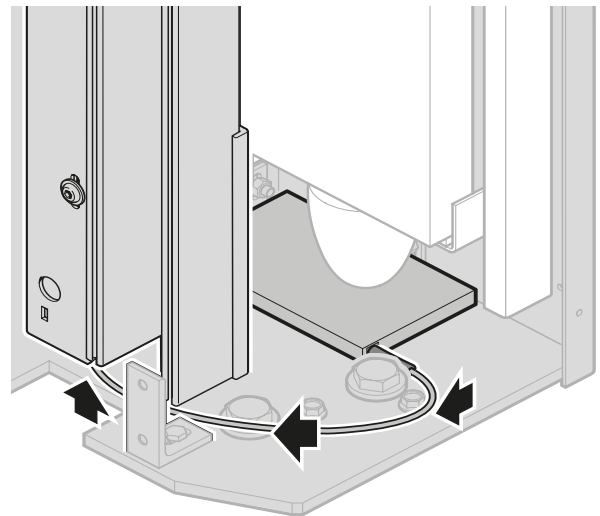

3.10 Install heater terminal boxes near the top of the LH and RH tracks.

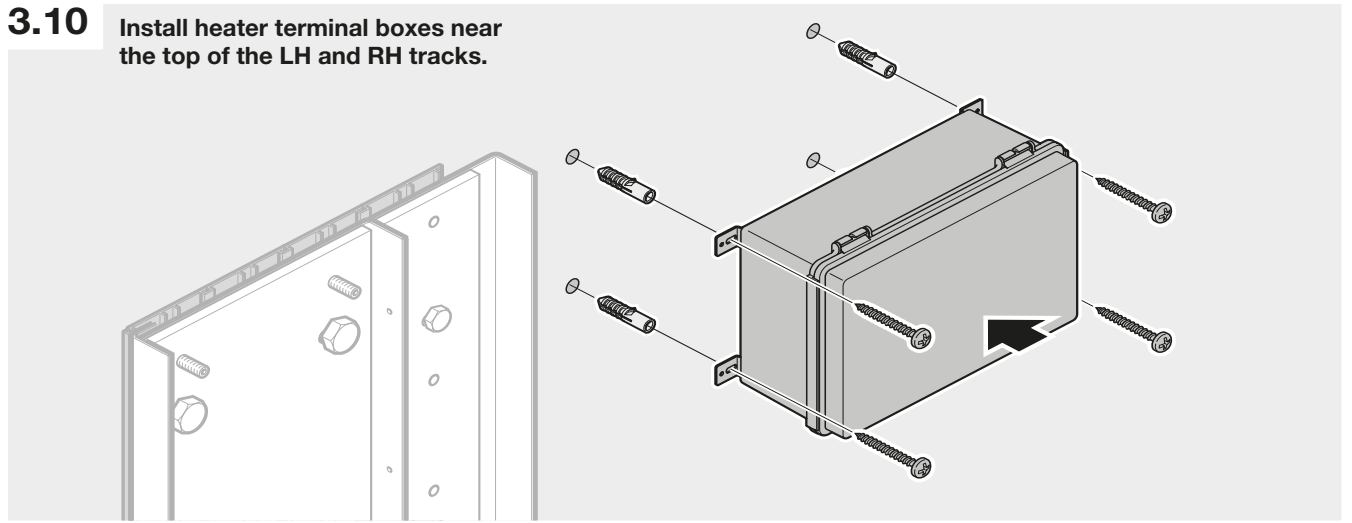

4a

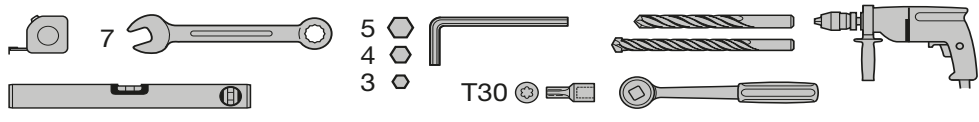
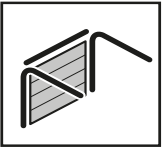

Panel curve installation for the "H" track configuration

4a.1
4a.2
4a.3

4a.1
4a.2
4a.3

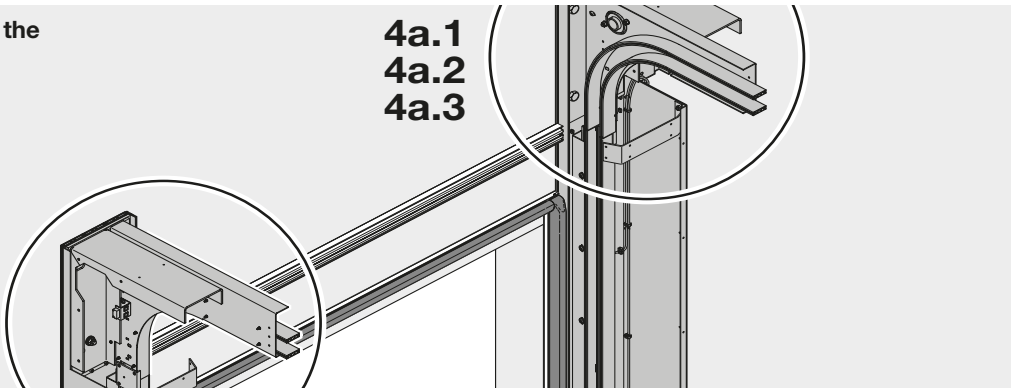

4a.1

Attach belt tracking sensor to bracket

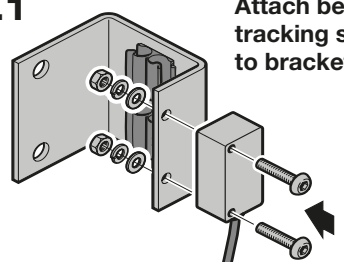

1

DIN7500 M6 x 12

If headroom ≥ 1000 (39-3/8) use position 1 otherwise use position 2

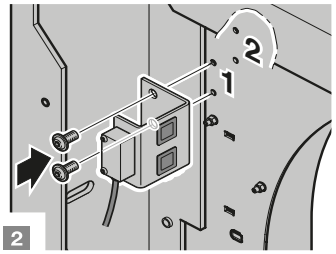

2

4a.2

DIN985 M12
Rest curve on installation supports to aid in bolt alignment

Attention: Do not fully torque as adjustments may be needed in the next steps

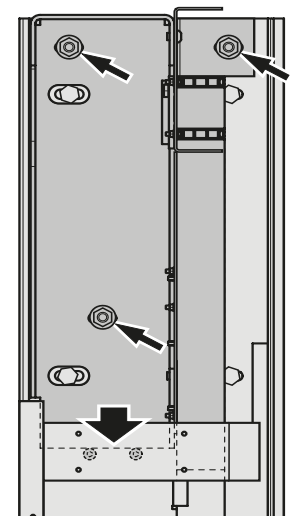
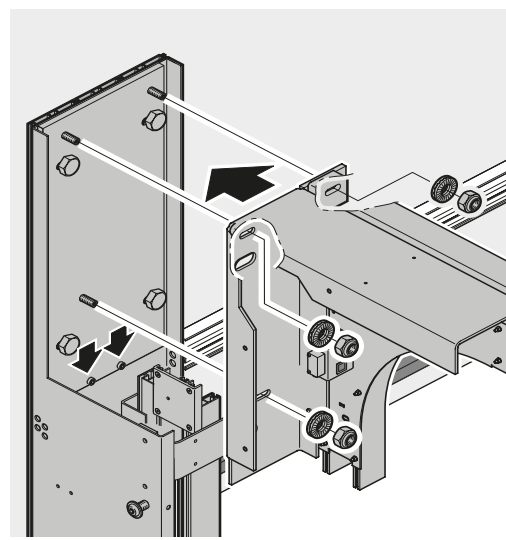

4a.3

Ensure that everything is aligned; up-down and left-right

Align aluminum wheel guides. Slide the splice bracket up and center over the splice

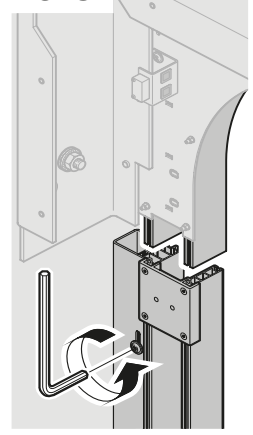

Loosen wheel guide support fasteners

1

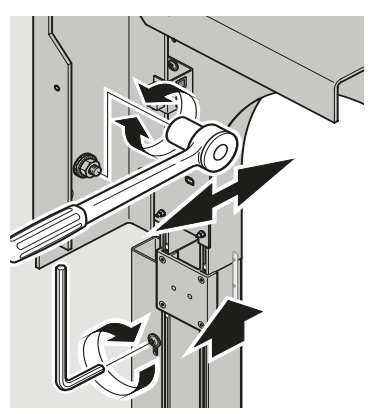

Move the aluminum wheel guide up until it butts against the curve guide. Re-tighten the fasteners

2

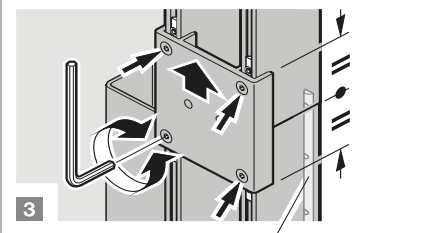
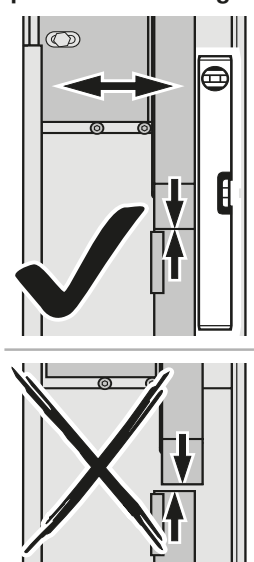

3

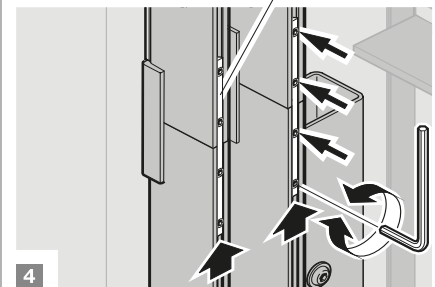

4

4b

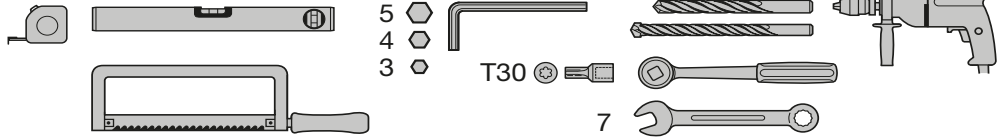
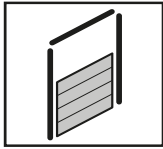

Shaft support installation for the "V" track configuration

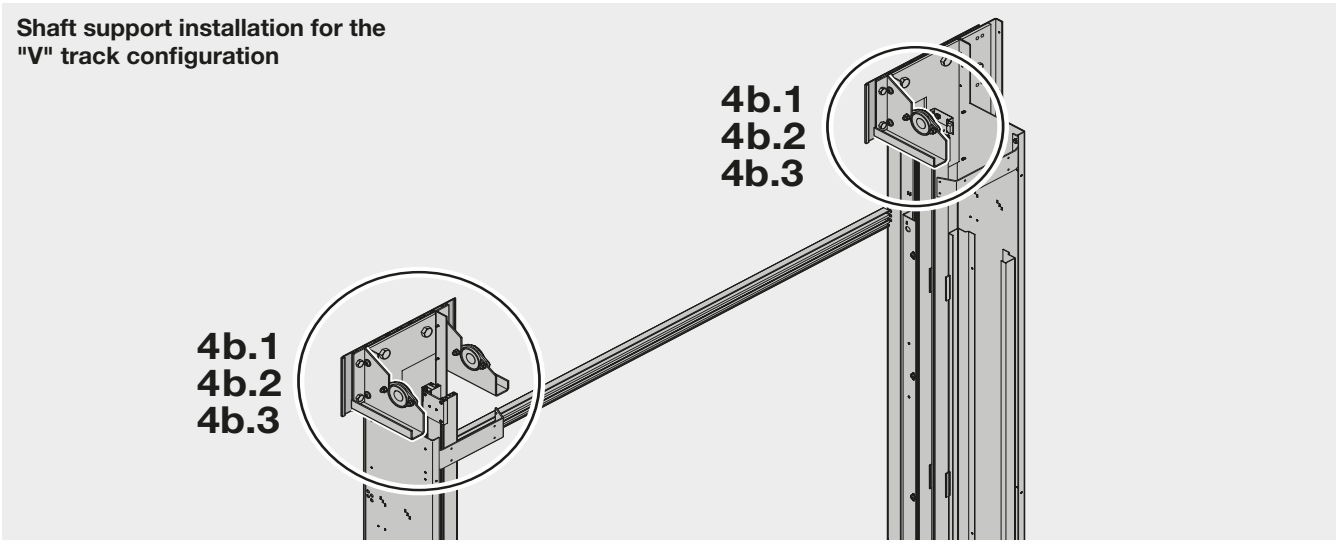

4b.1 Attach belt tracking sensor to bracket

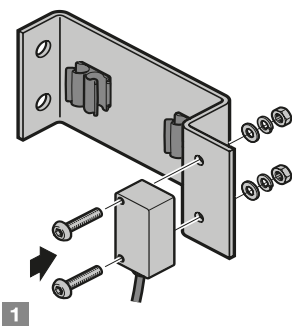

Install the belt tracking bracket to the tracks

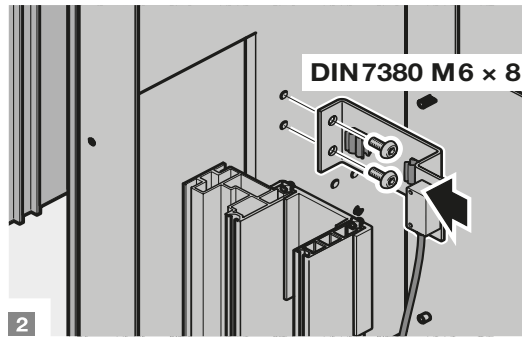

4b.2 DIN7500 M6 x 12

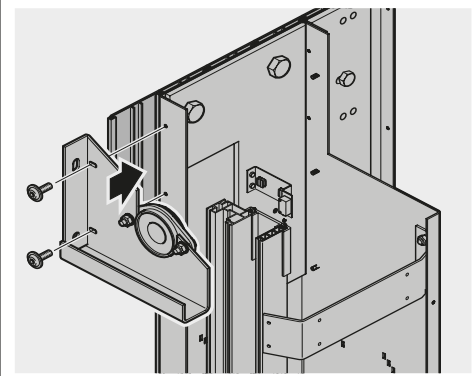

4b.3 Attach shaft support to wall

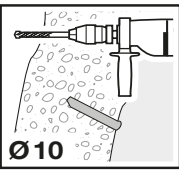

Hardware by others

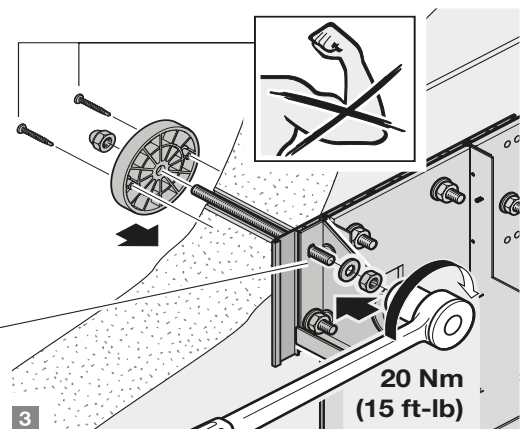
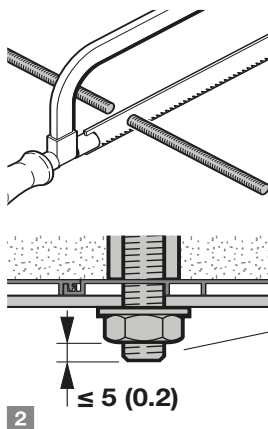
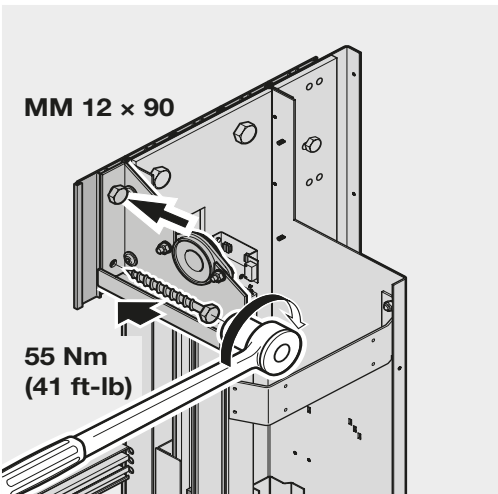
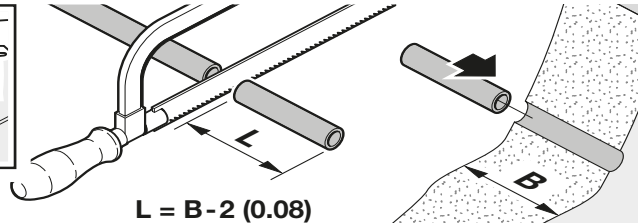
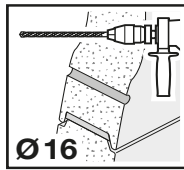

5a

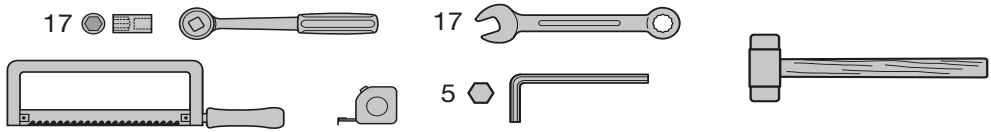
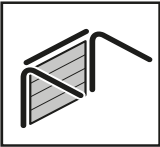

Drive shaft installation for the "H" track configuration

5a.4

5a.1
5a.2
5a.3

5a.1
5a.2
5a.3

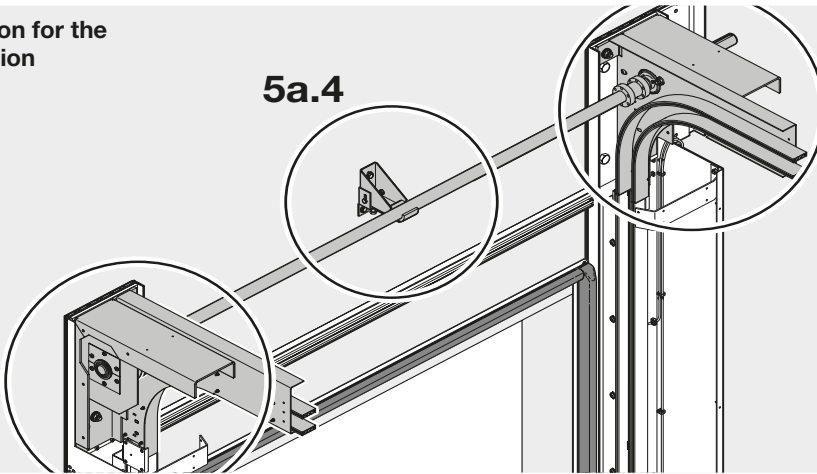

5a.1

Remove bearing from curves to allow clearance for the shaft installation

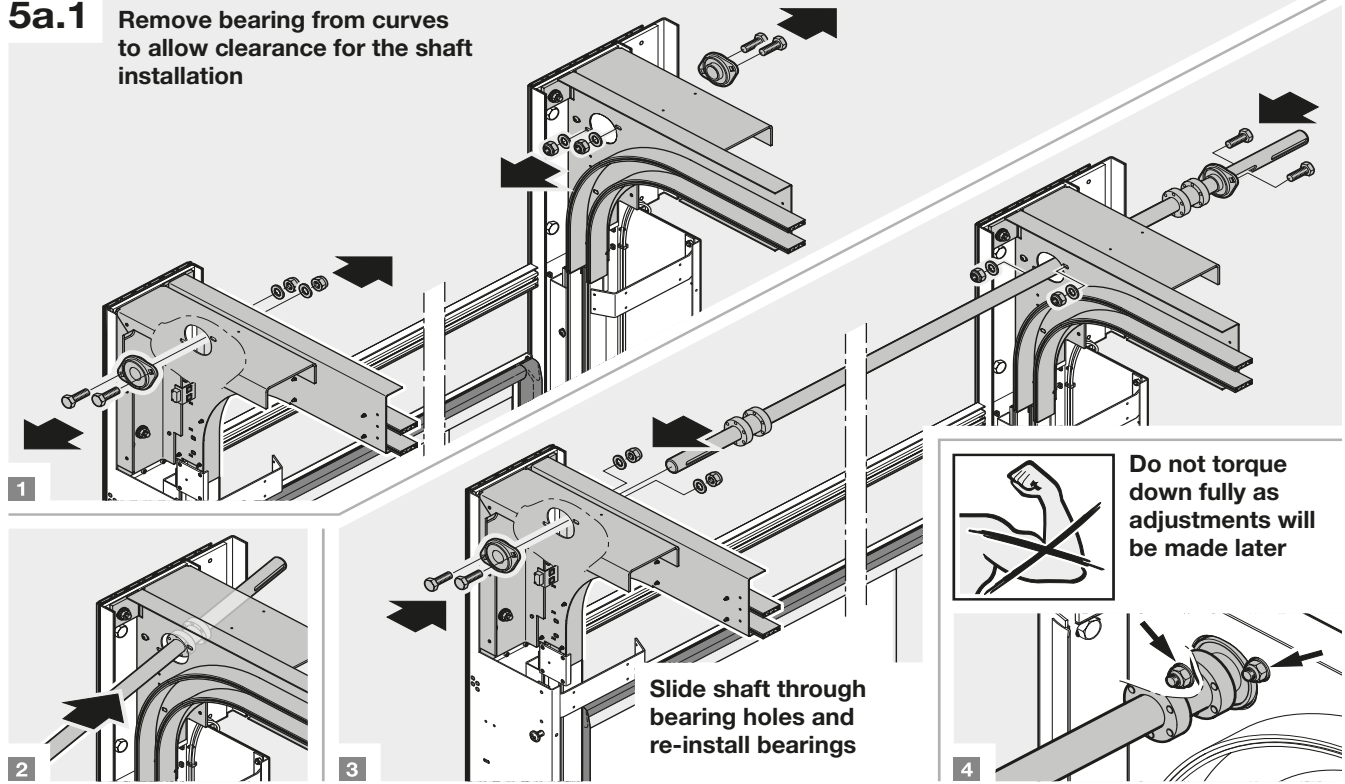

5a.2



185
(7-5/16)

345
(13-9/16)

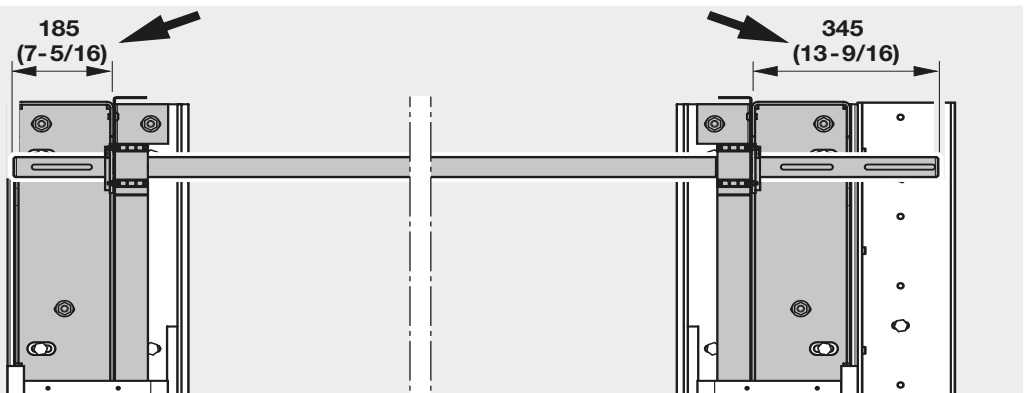

5a.3



Doors with no counterweights

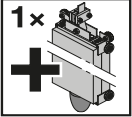
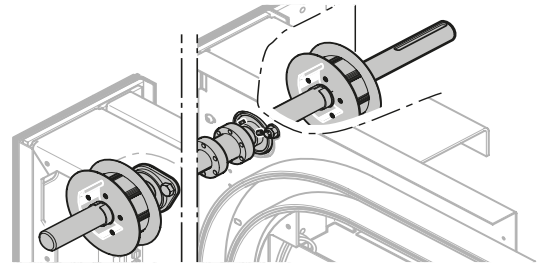
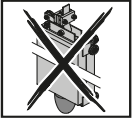

Doors with one counterweight

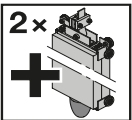
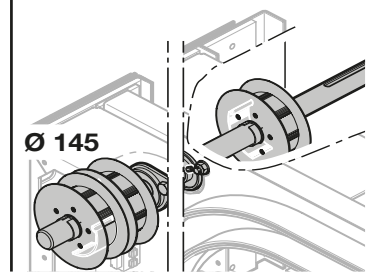
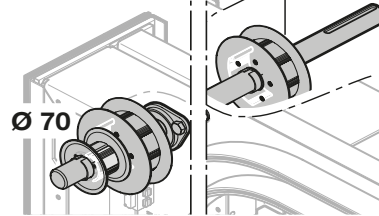
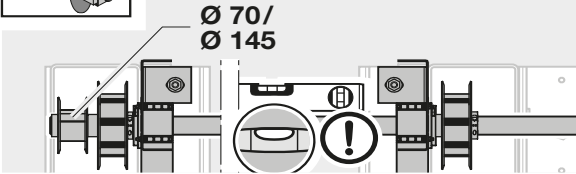

Doors with two counterweights

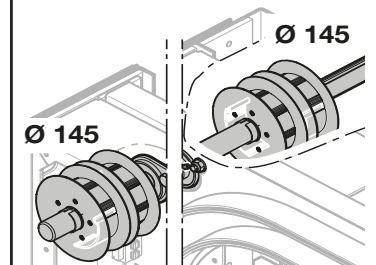
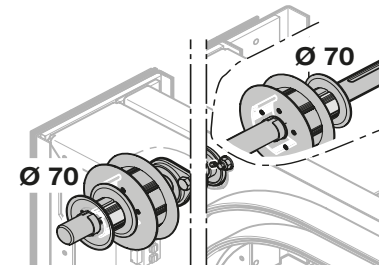
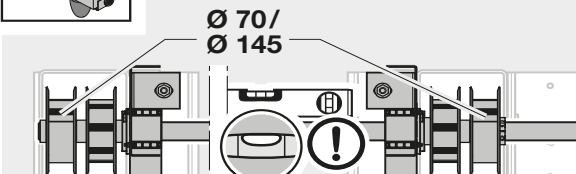

Ensure that the belt clamp is in the correct orientation when sliding pulley onto shaft

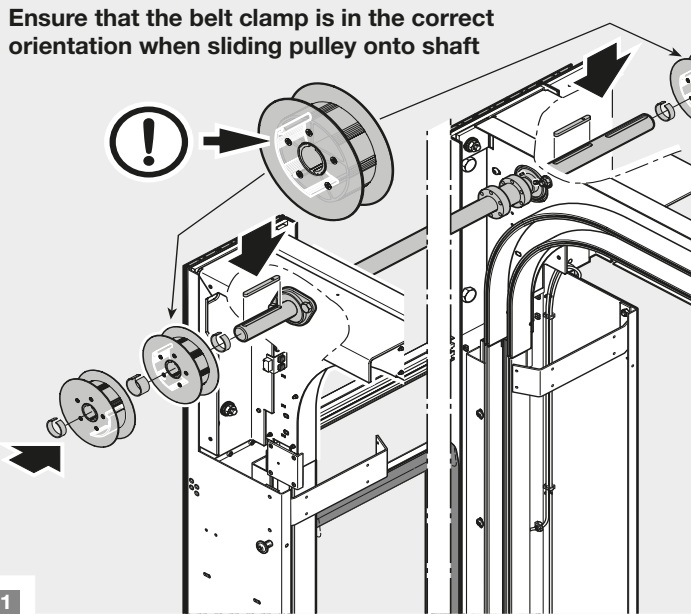

Install keys using a plastic mallet

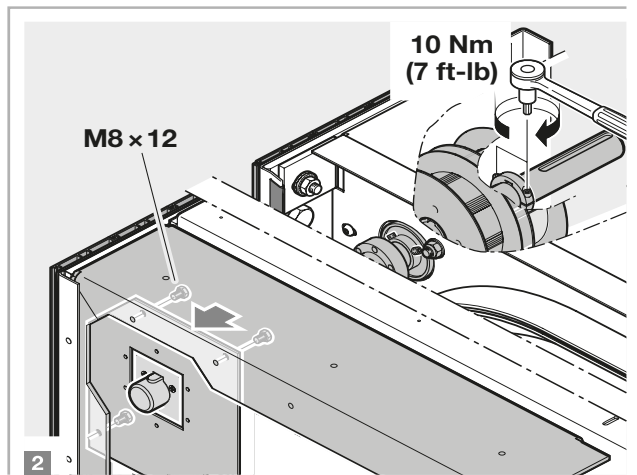

5a.4

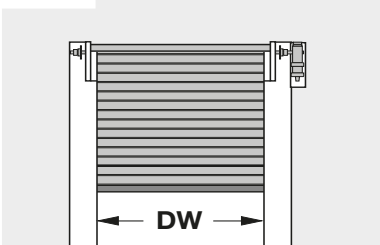

DW > 3500
(137-3/4)



DW > 5000
(196-13/16)

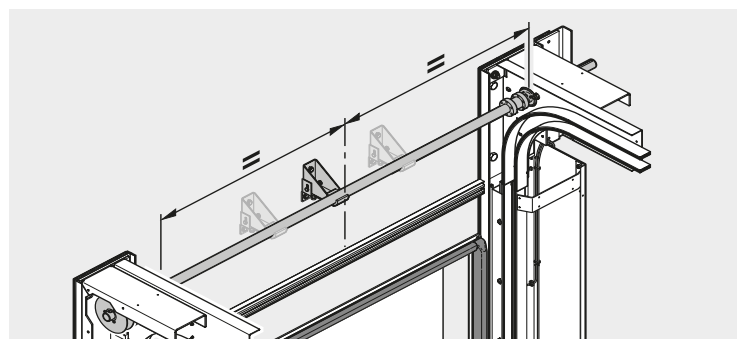

5a.5a

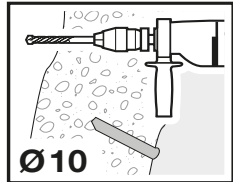

DIN 571 8 x 50
S 10
DIN 125 Ø 8.4

Hardware by
others

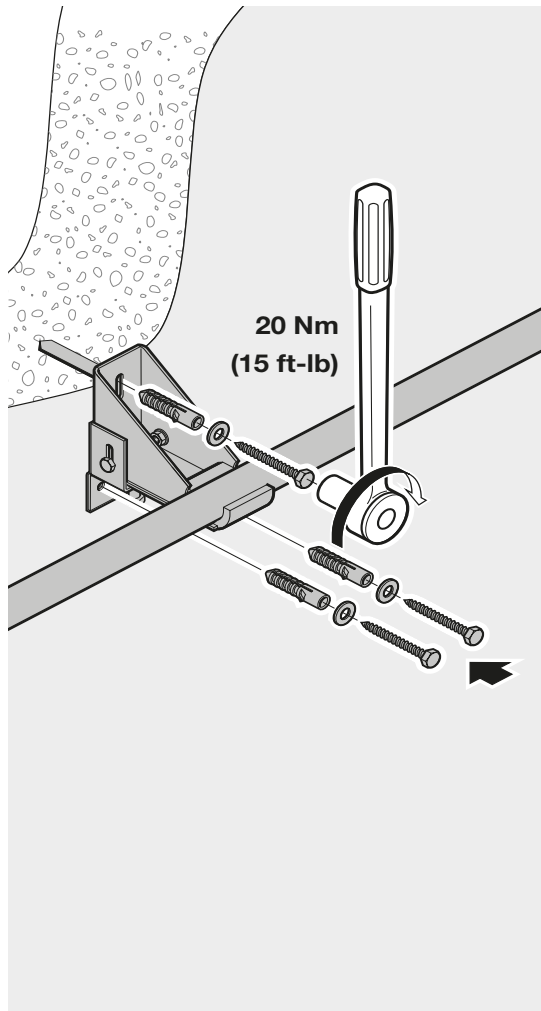

5a.5b

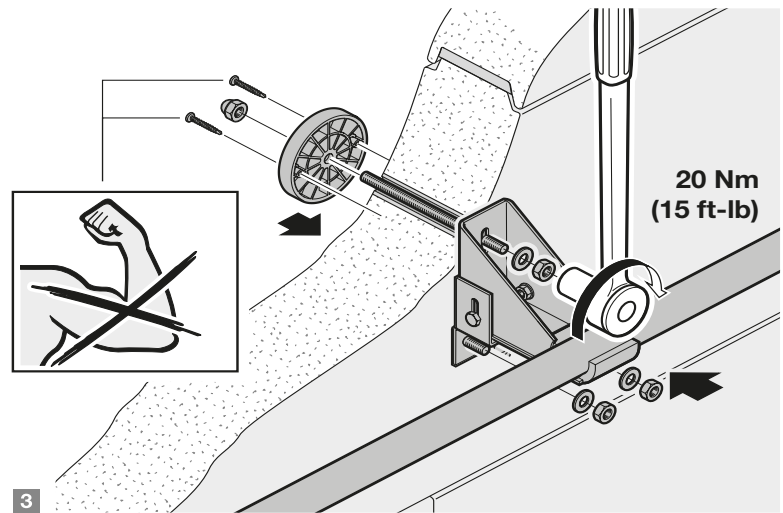
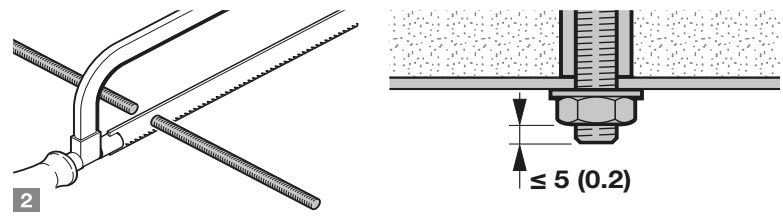
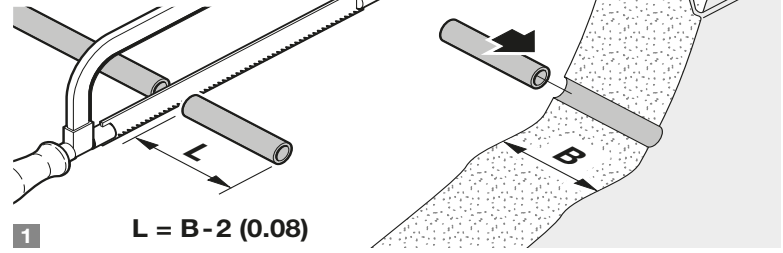
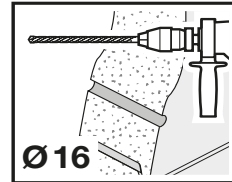

5a.6

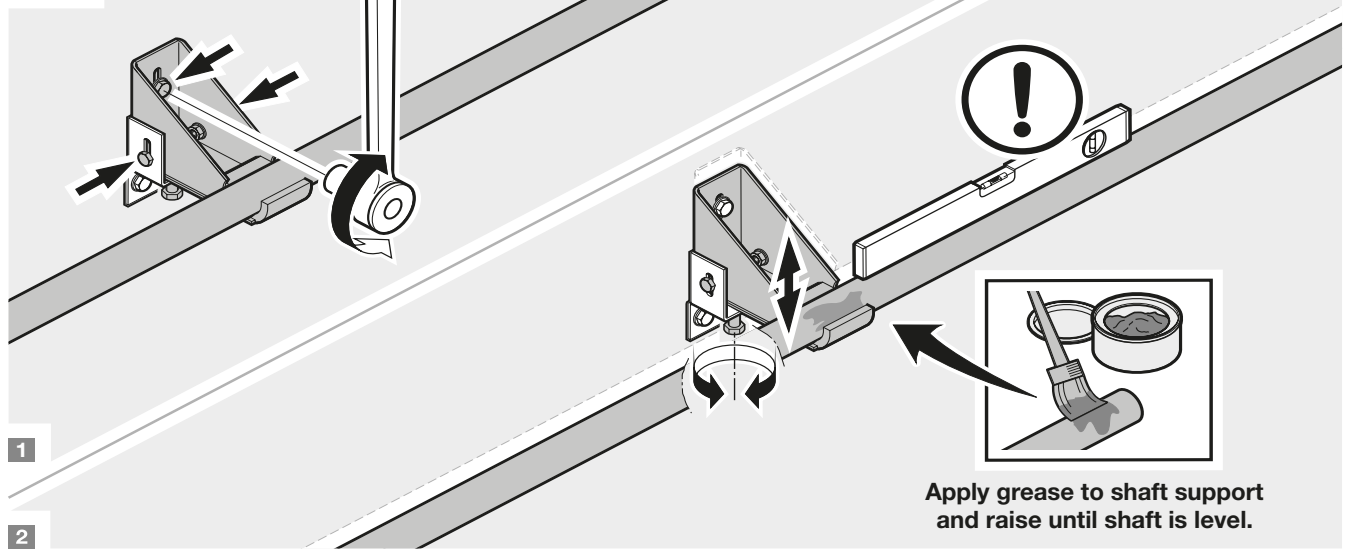

5b

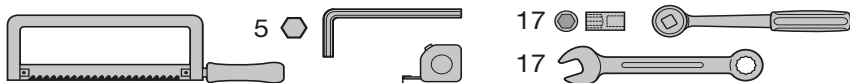
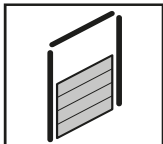

Drive shaft installation for the "V" track configuration

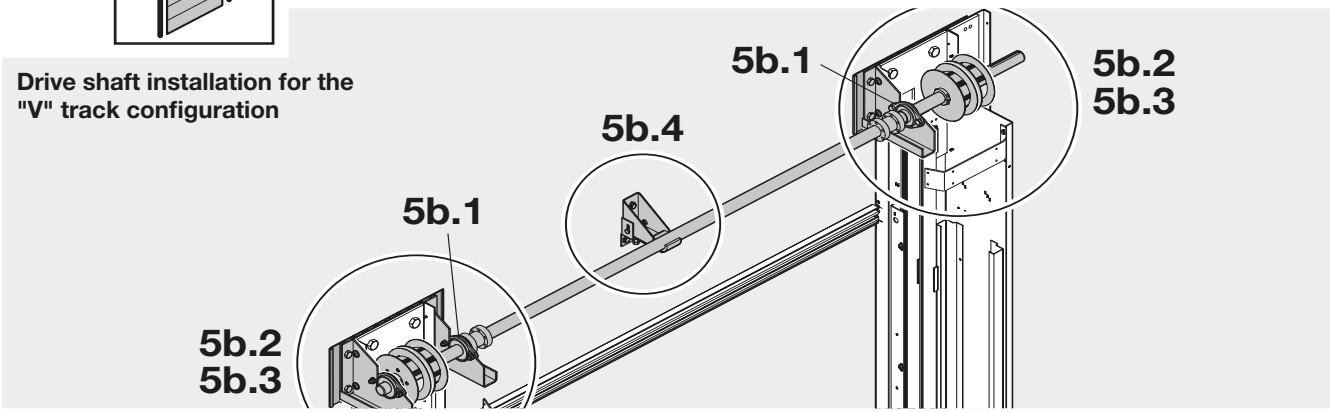

5b.1

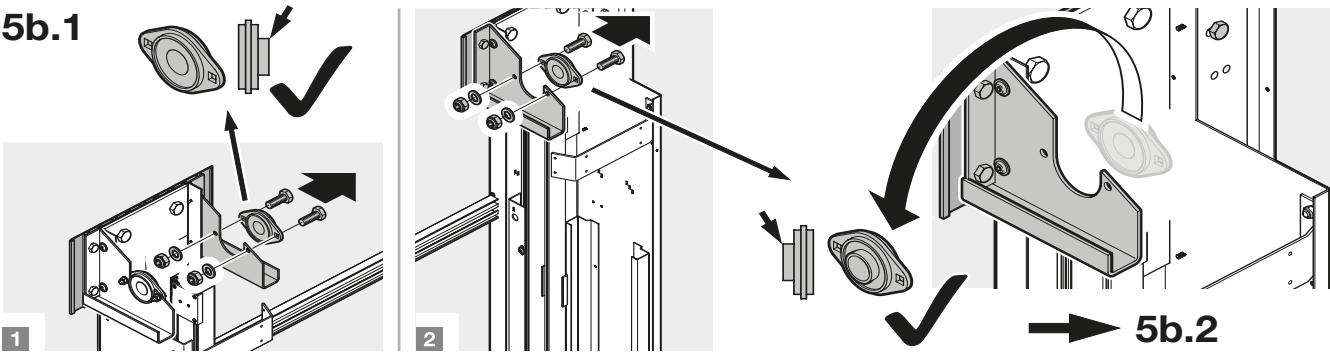

5b.2

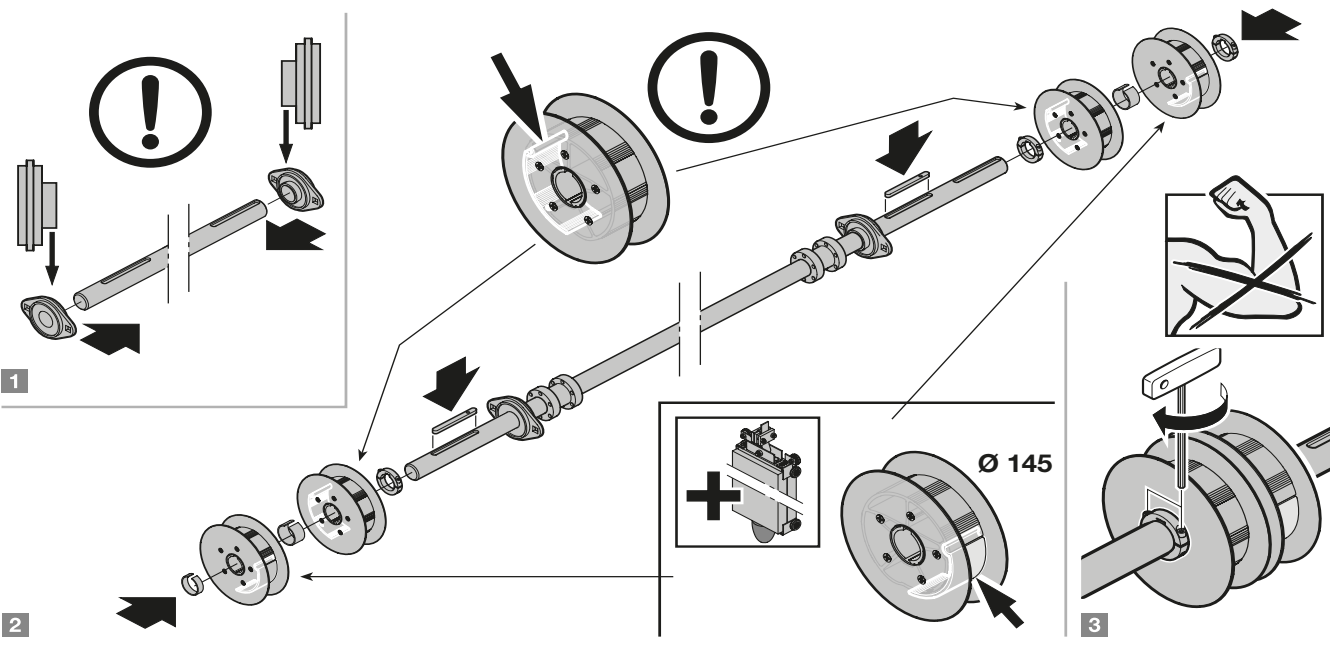
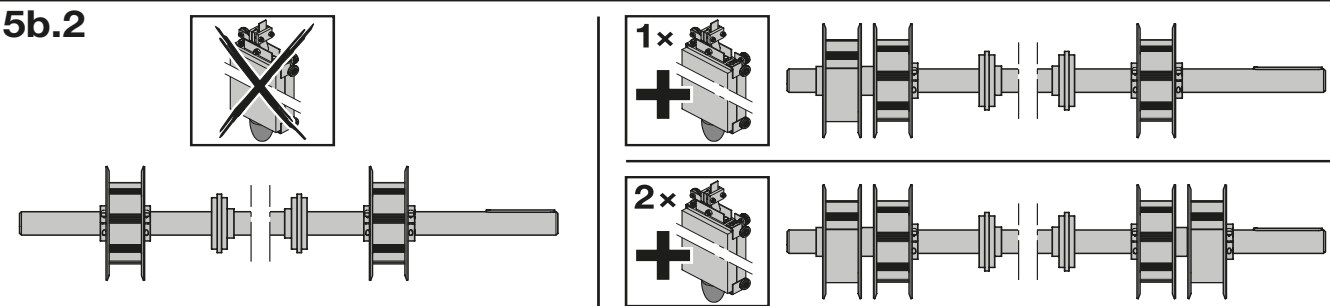

5b.3

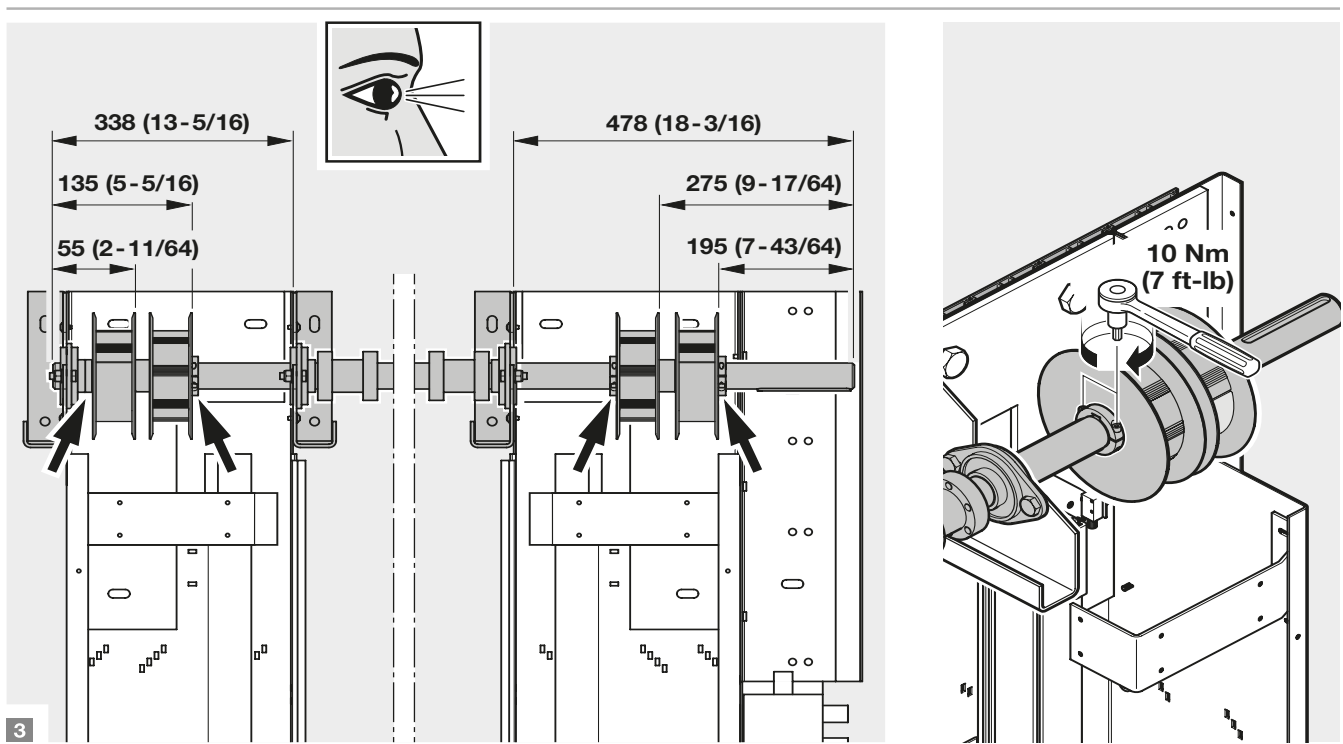
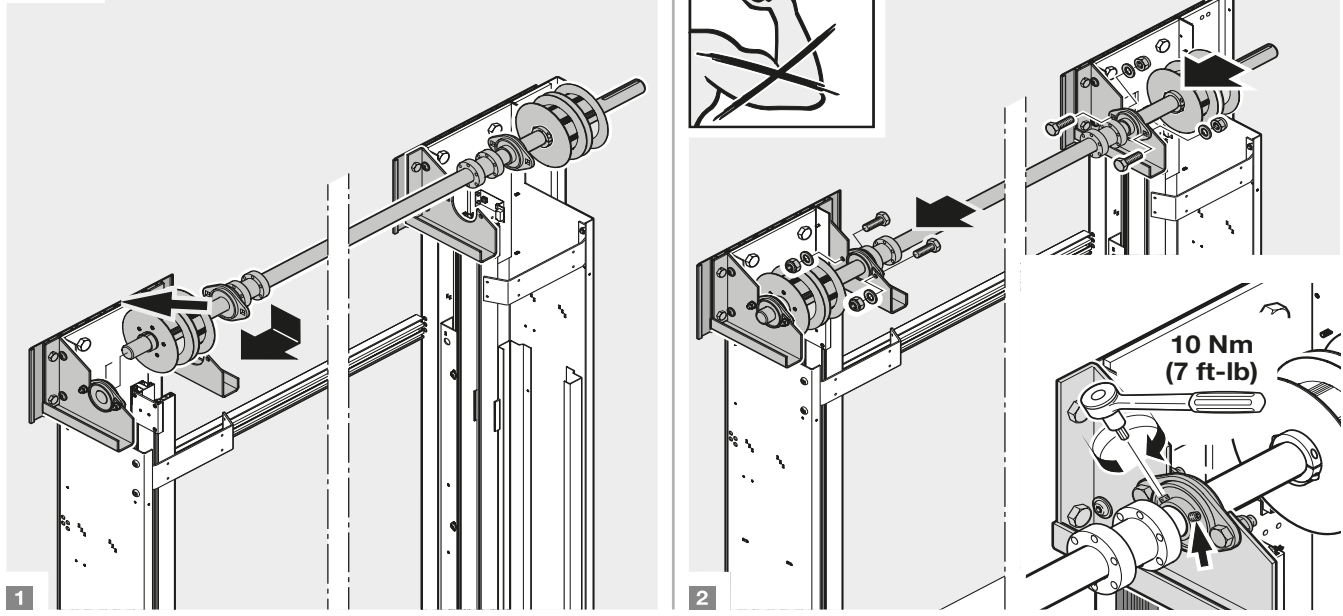

5b.4

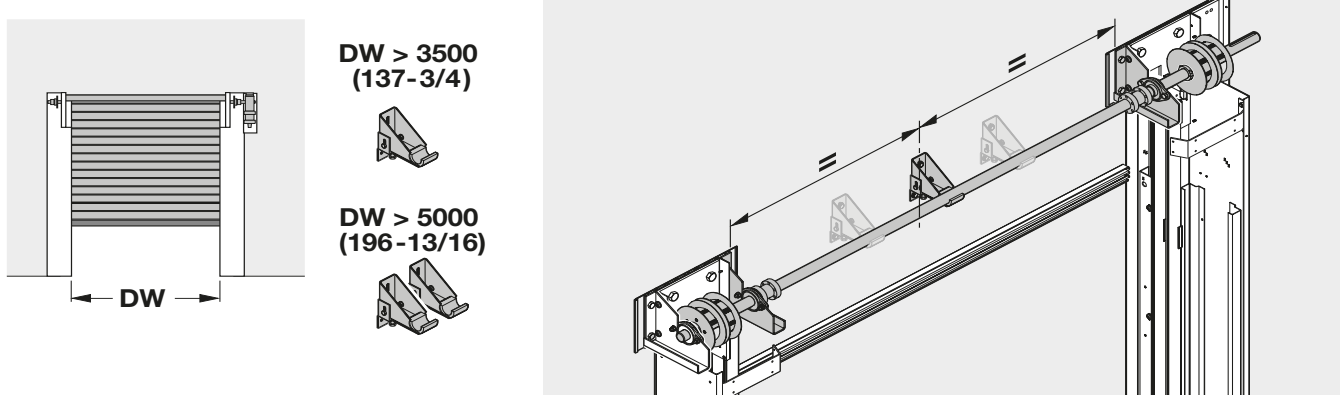

5b.5a

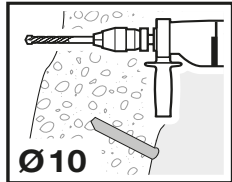

DIN 571 8 × 50
S 10
DIN 125 Ø 8.4

Hardware by others

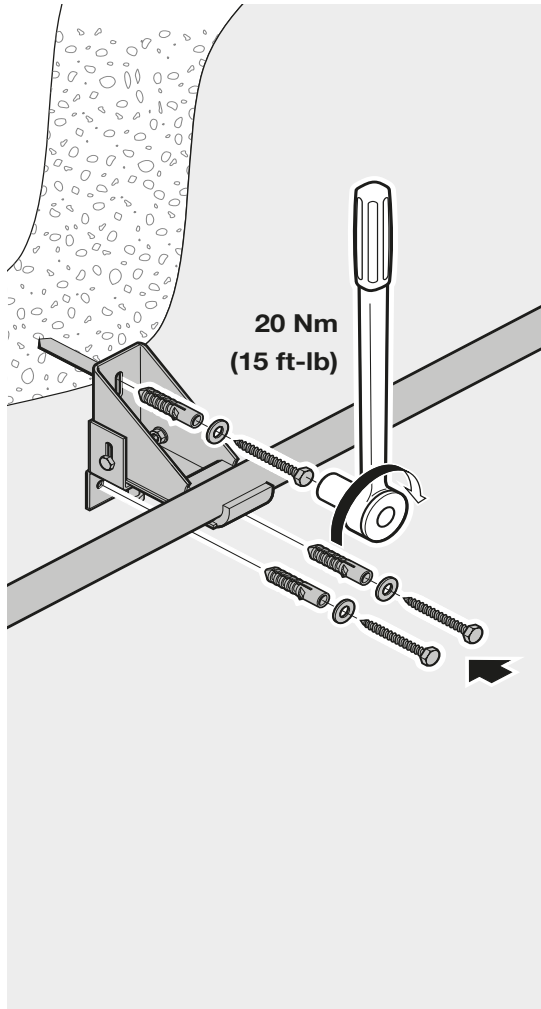

5b.5b

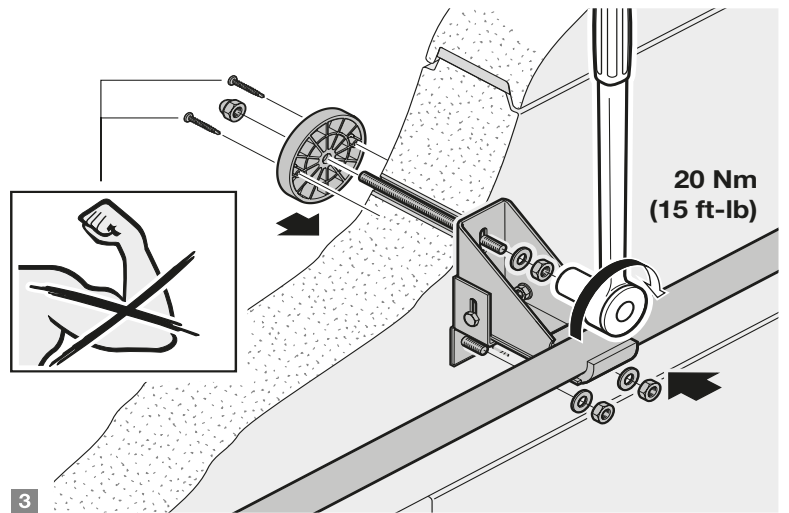
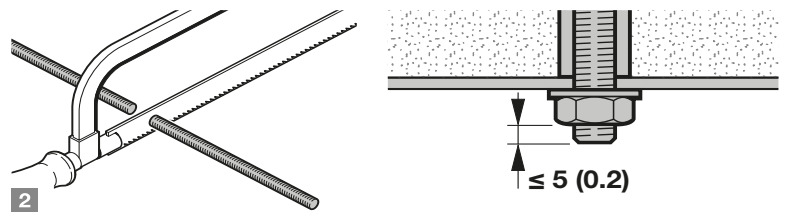
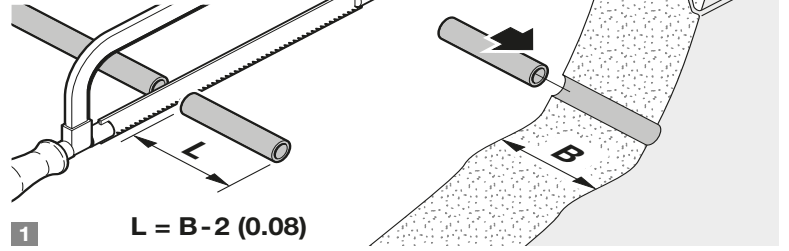
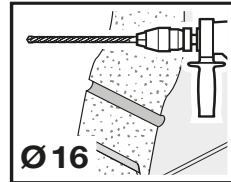

5b.6

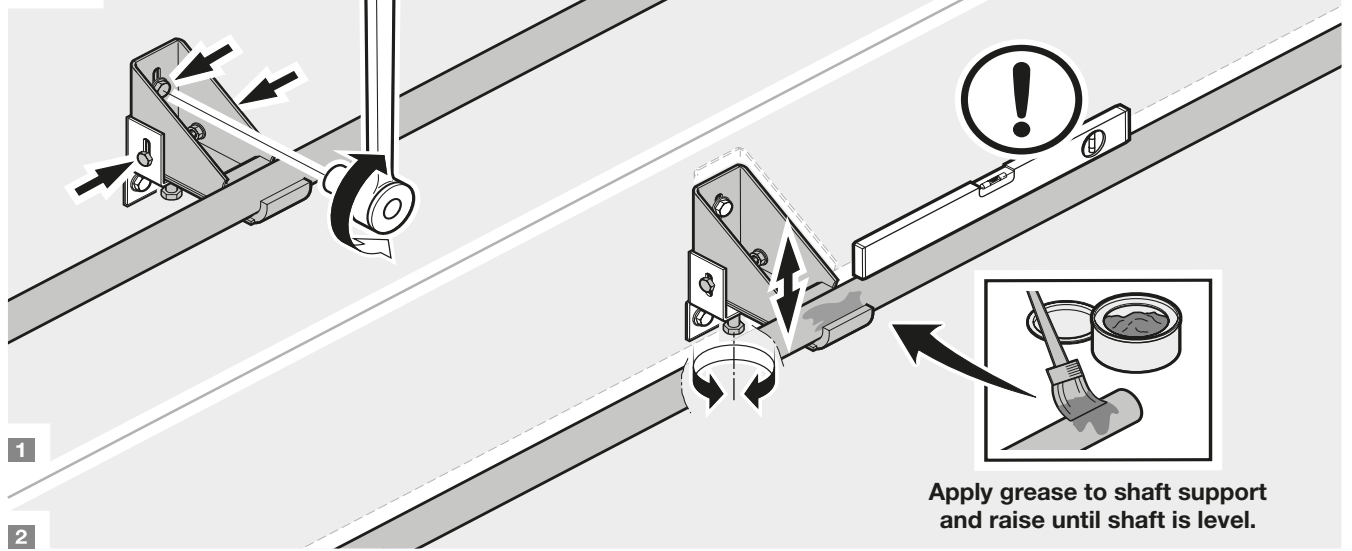

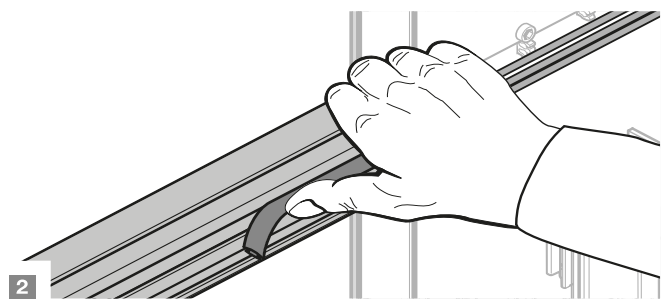
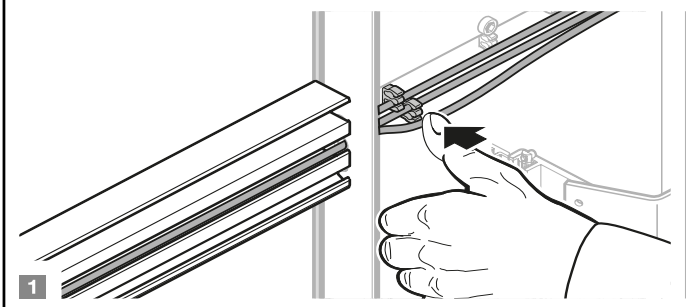
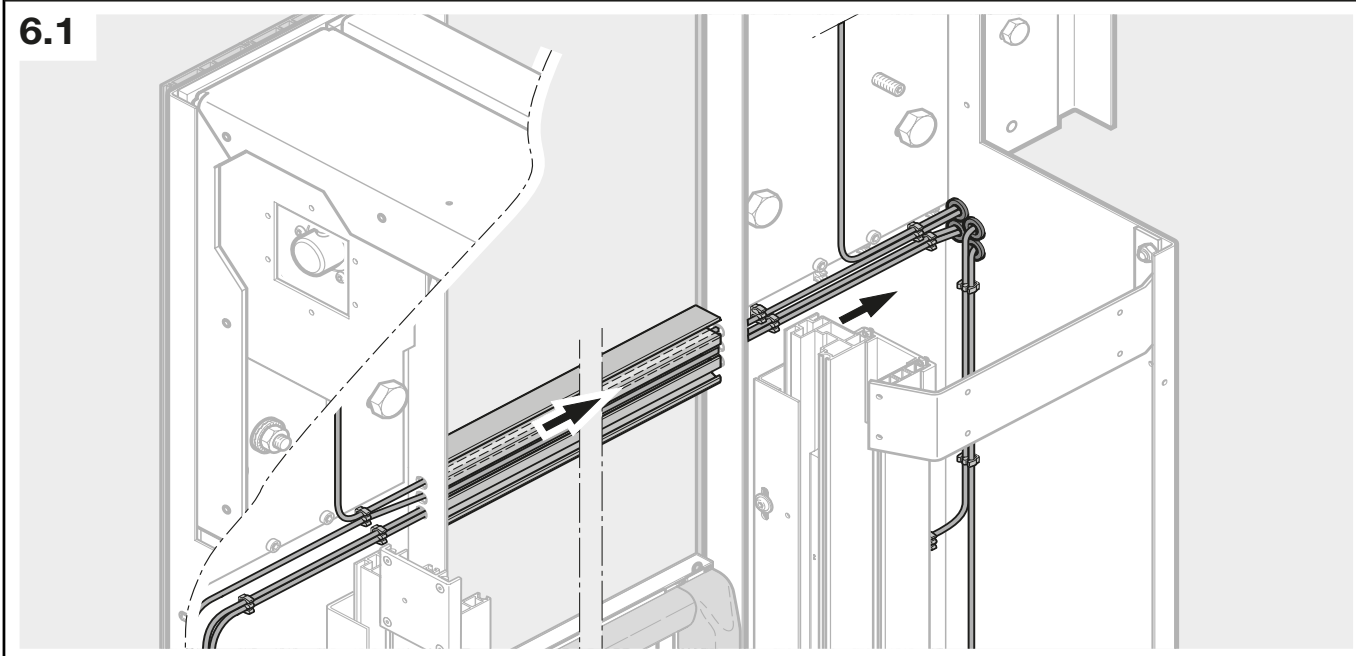
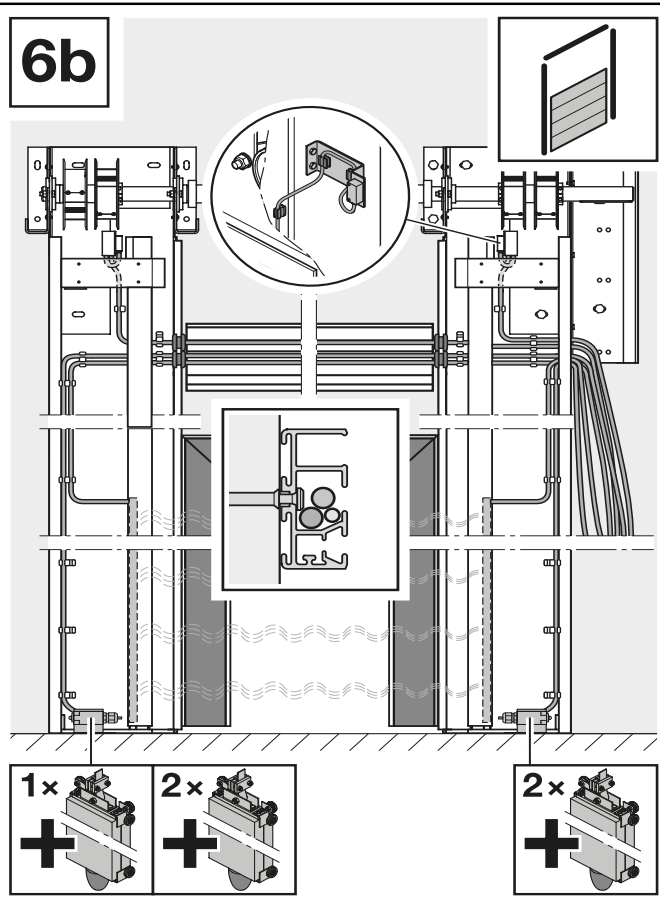
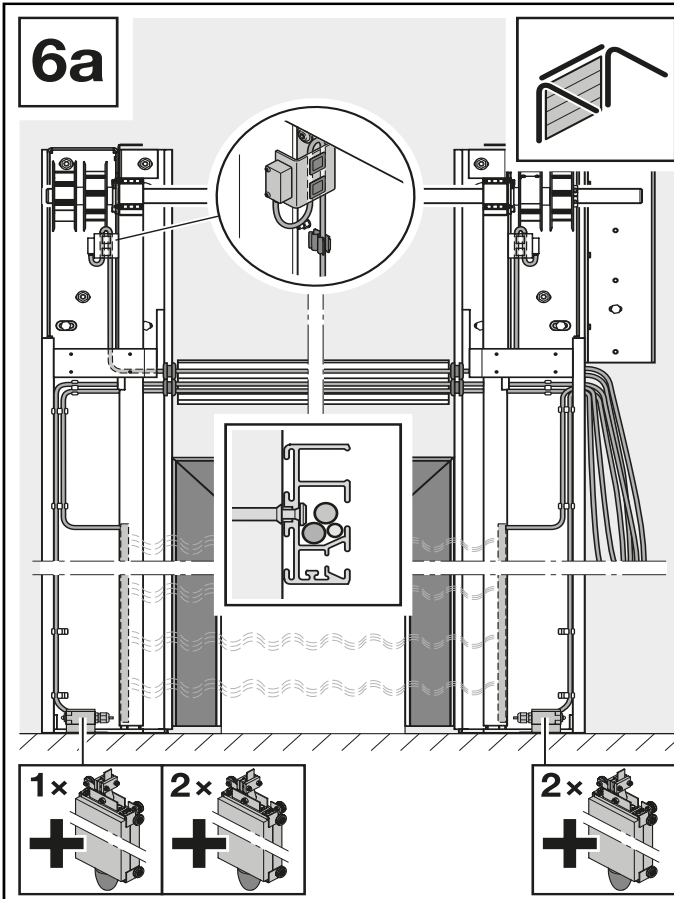

7

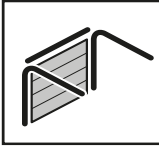

3



17



17

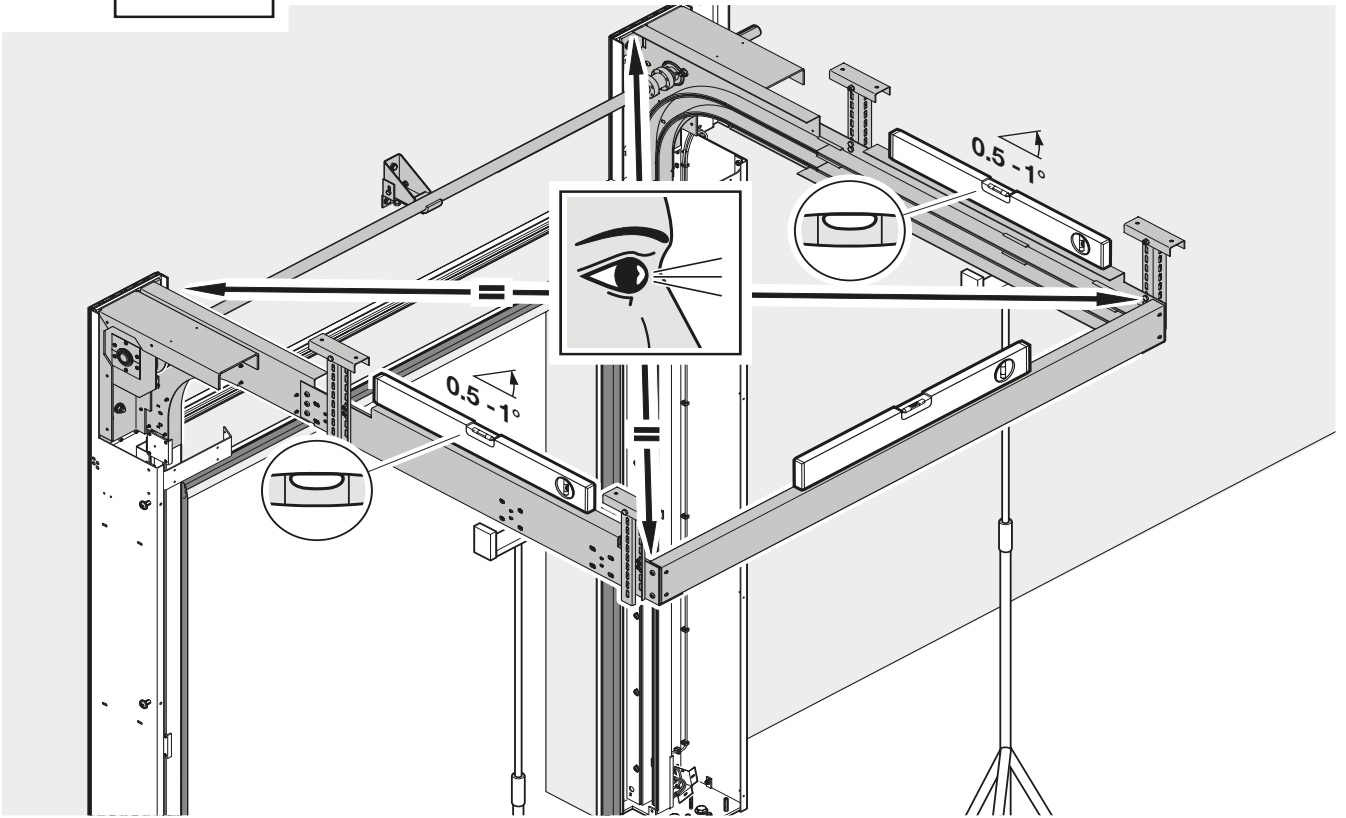

7.1

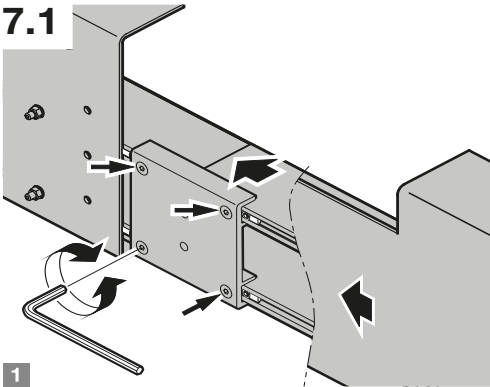

1

DIN7500 M6 x 12

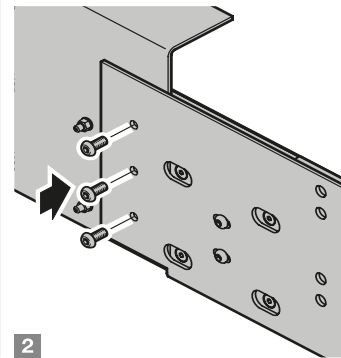

2

7.2

DIN7500 M6 x 12

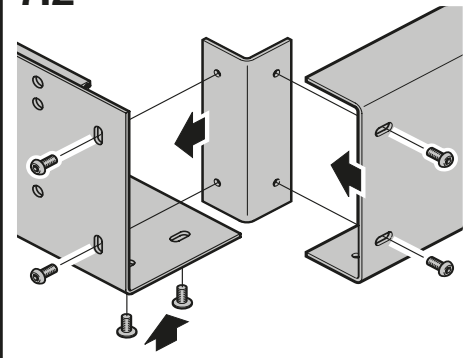

7.3

DIN933 M8 x 20
DIN125 Ø8.4
DIN985 M8

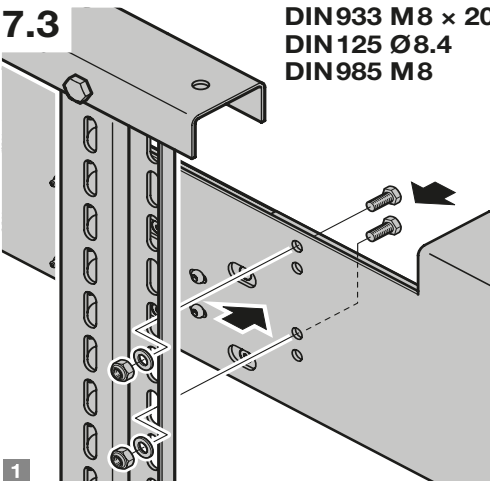

1

DIN933 M8 x 20
DIN125 Ø8.4
DIN985 M8

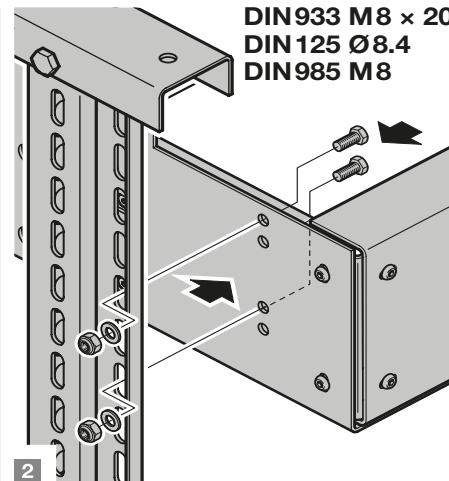

2

SXRL 10 x 60 FUS

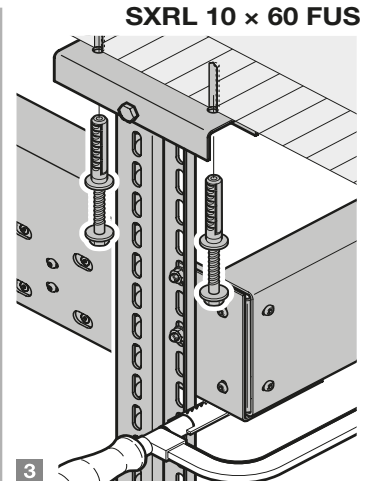

3

8

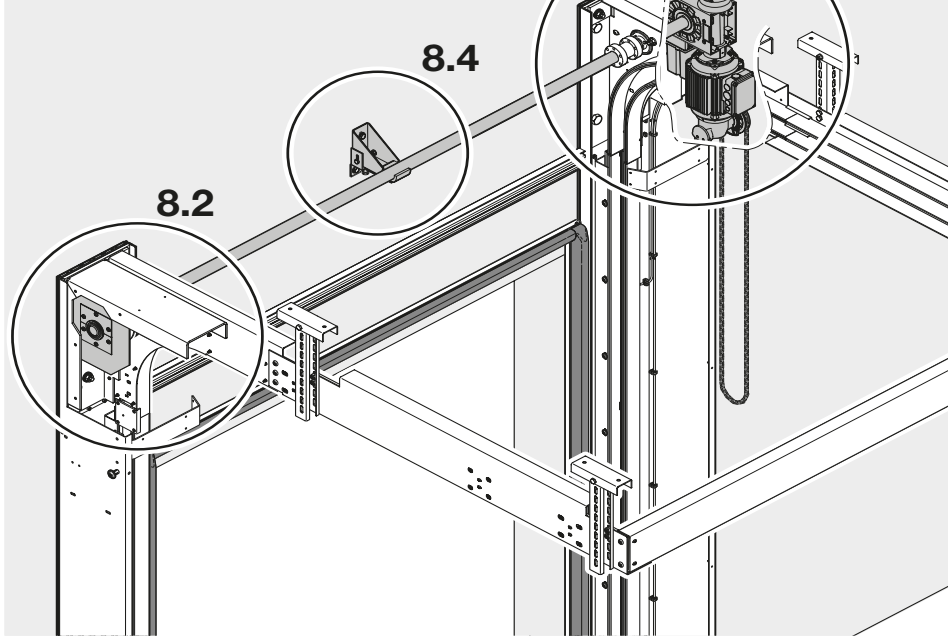
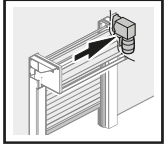
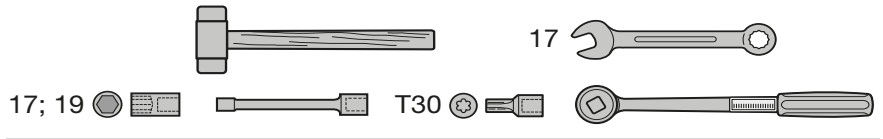
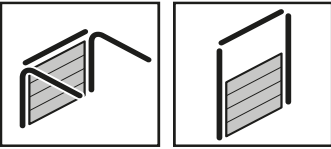

8.1
8.2
8.3

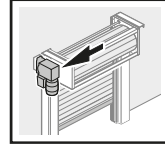

If motor handling is LH, rotation of the chain fall device may be required.

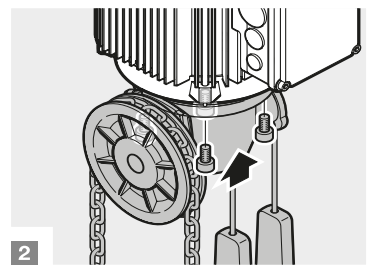
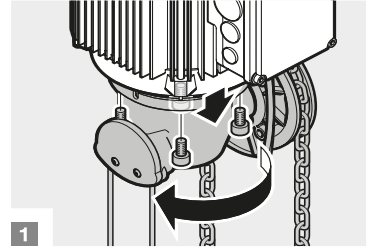

8.1

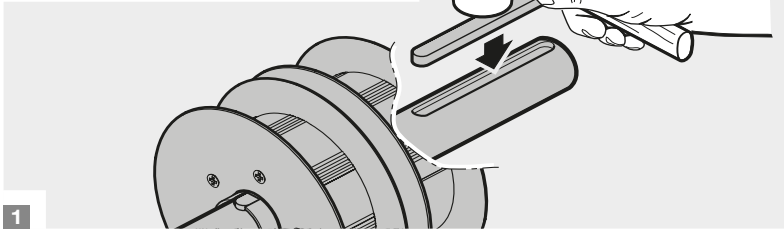
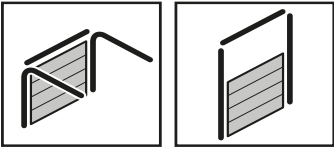

1

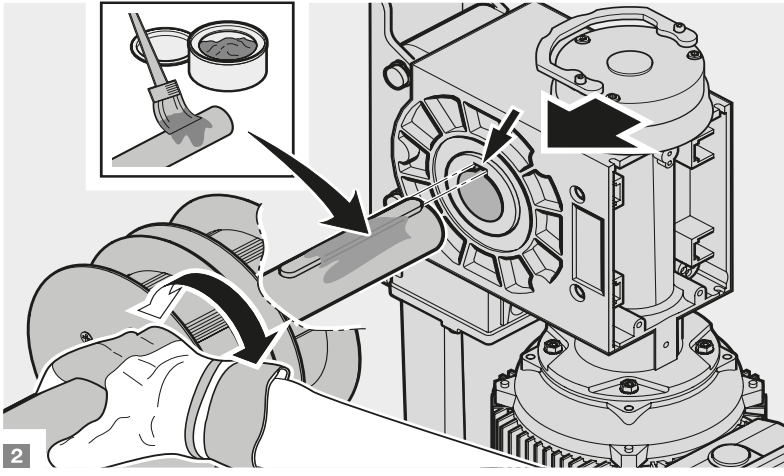

2

DIN933 M12 x 45
Install bottom bolt first

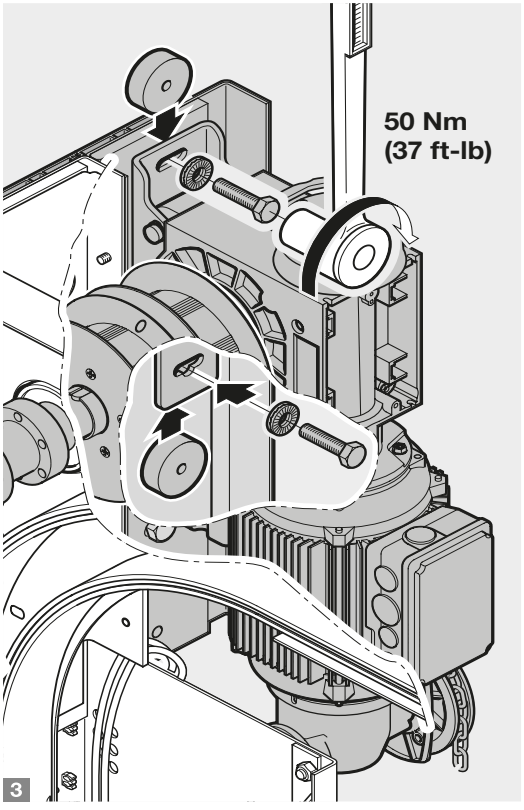

50 Nm
(37 ft-lb)

3

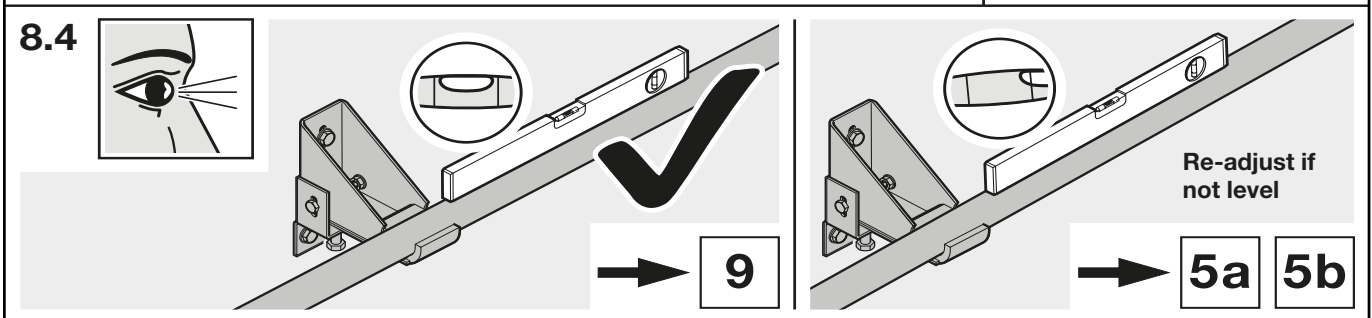
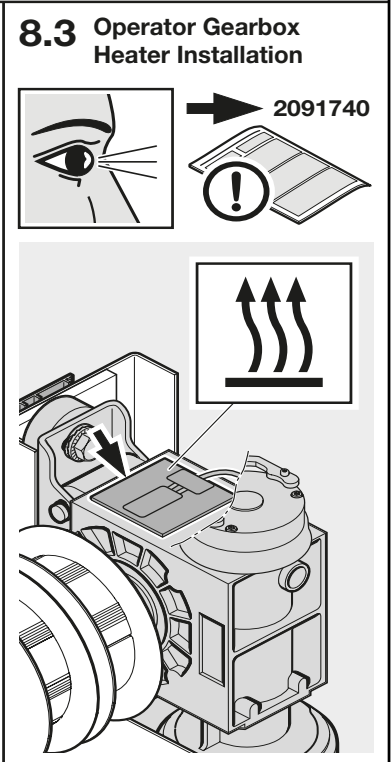
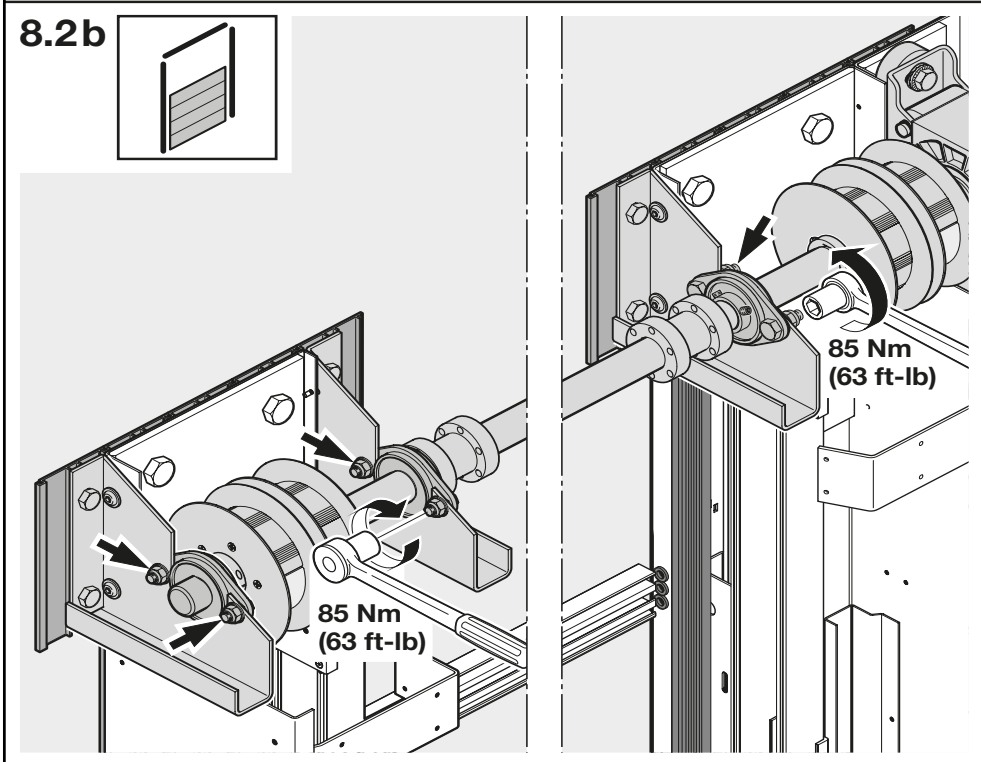
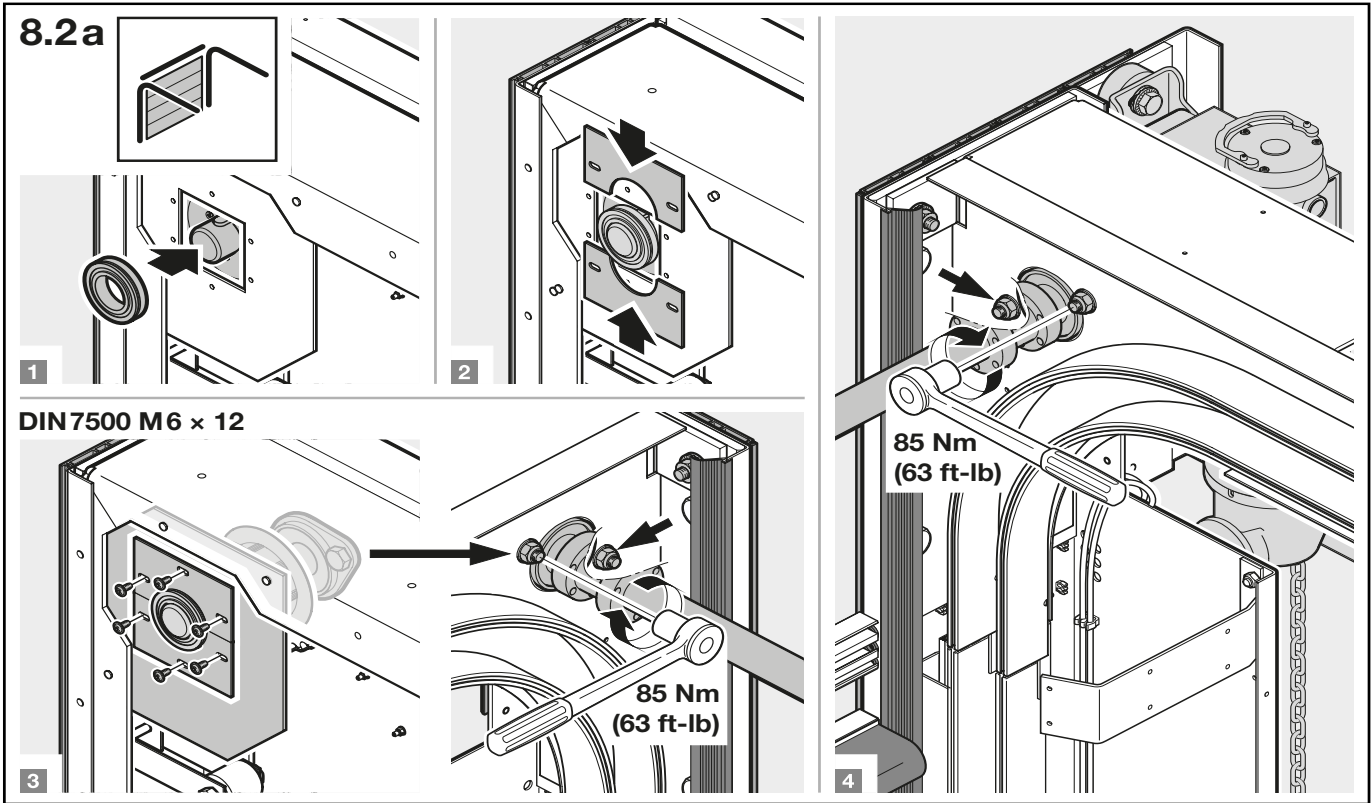

9

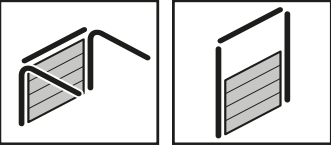

3 2.5

13



13



T30

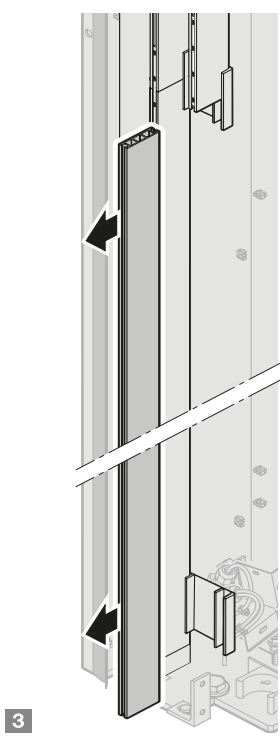
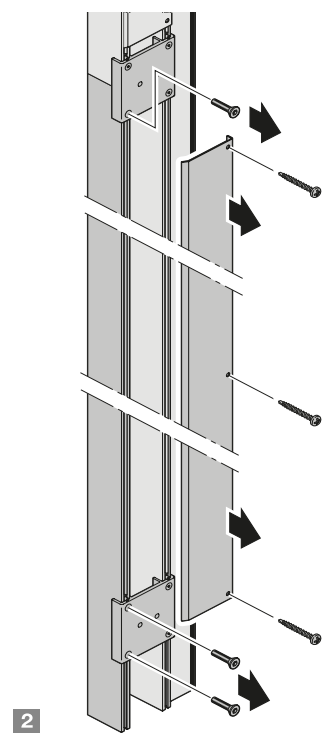
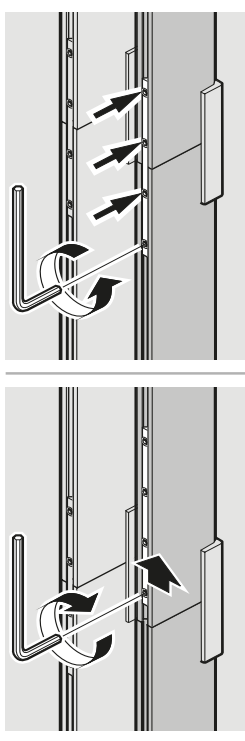
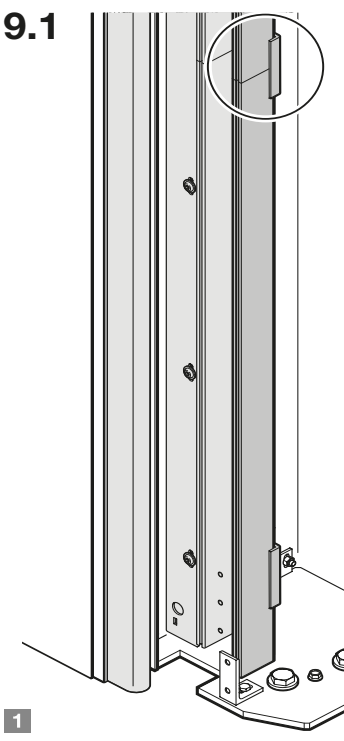
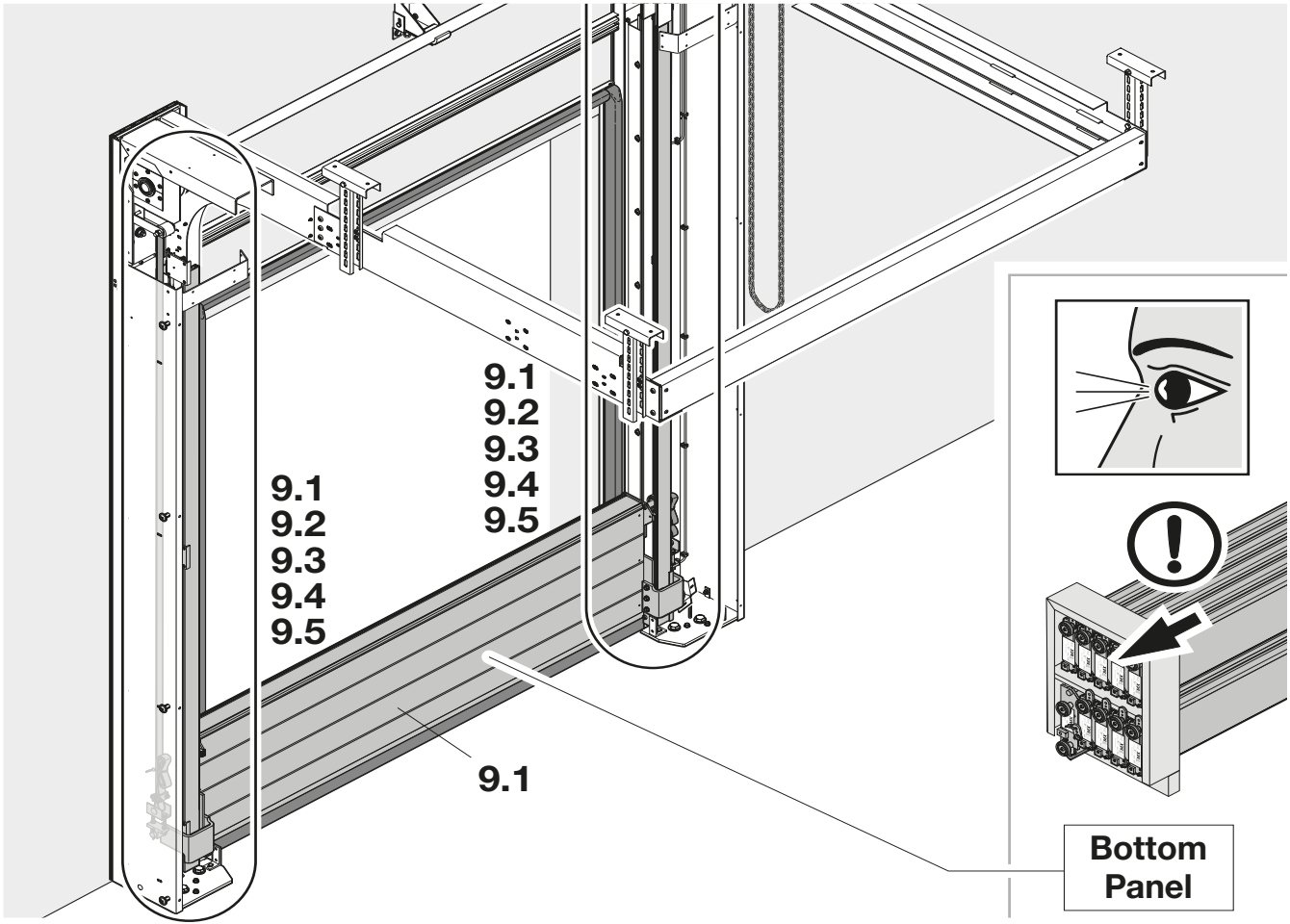

9.2

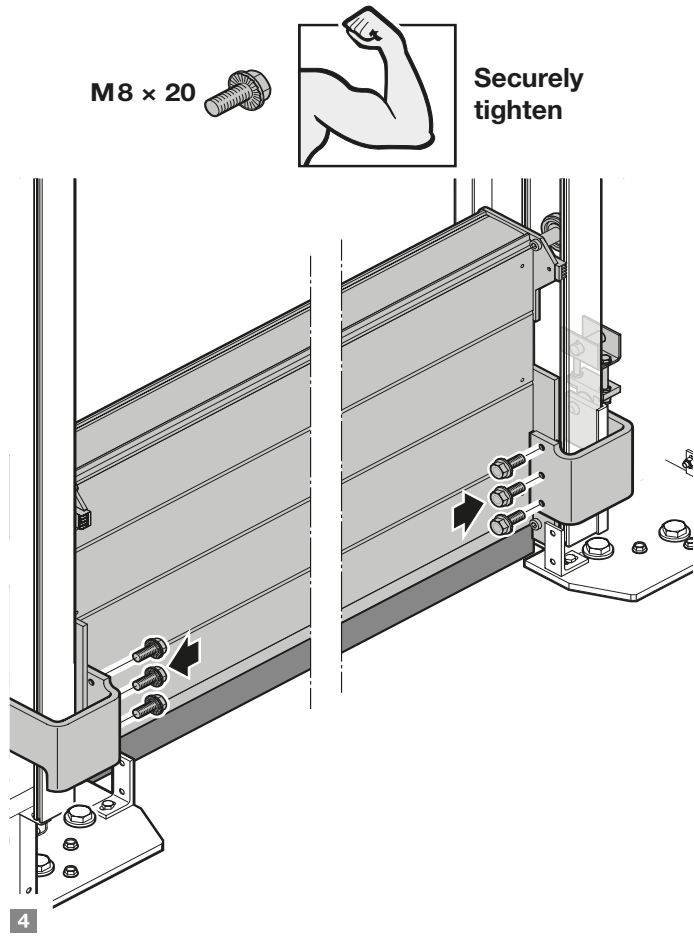
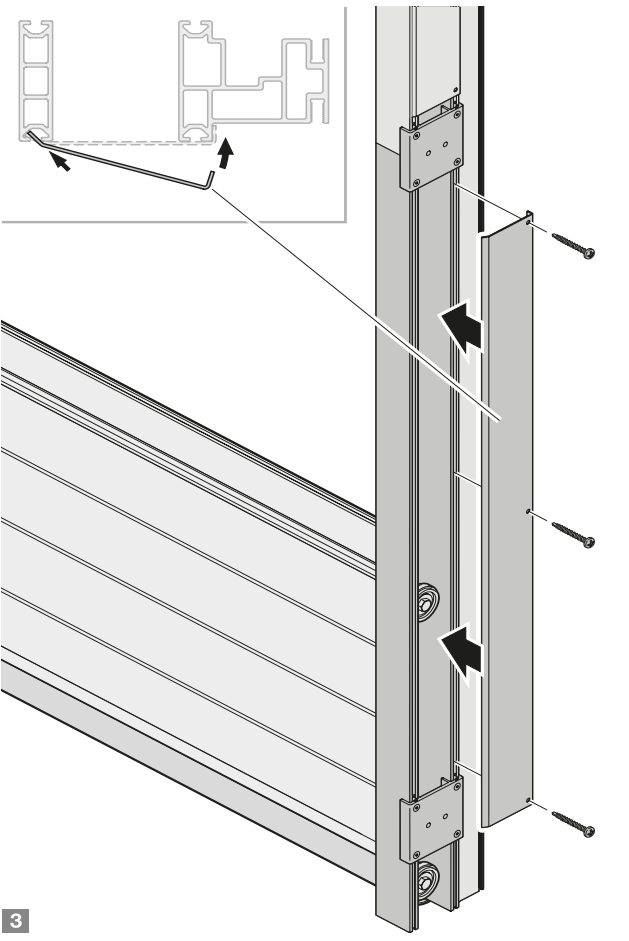
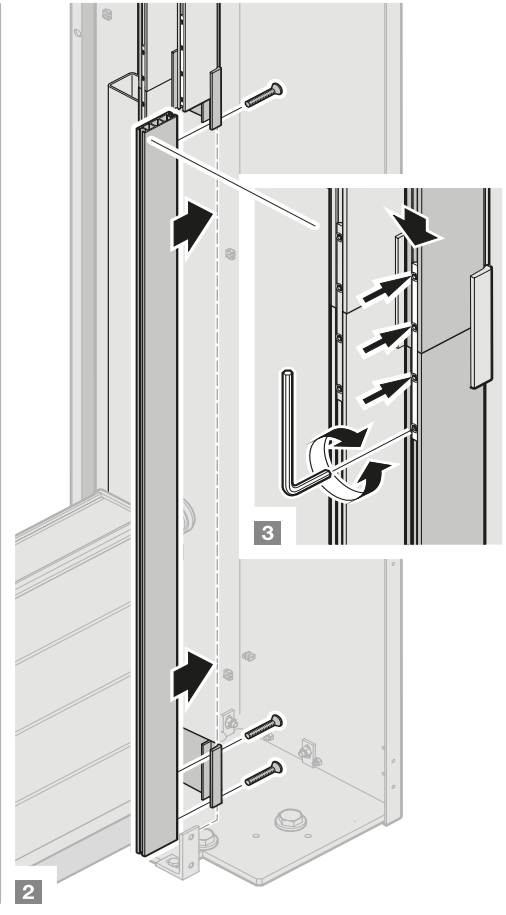
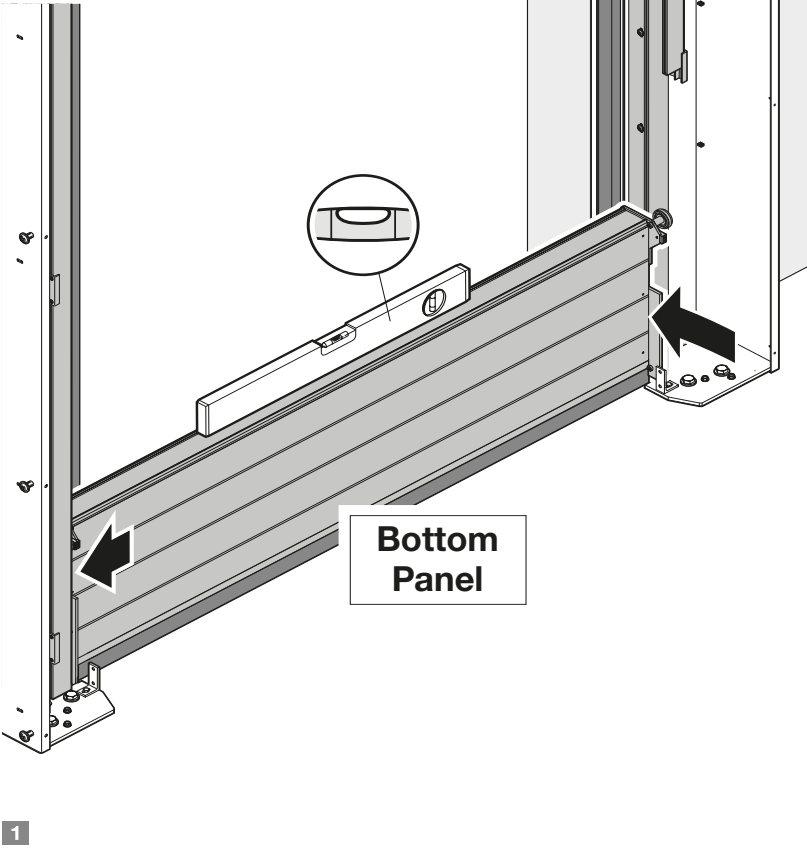

9.3

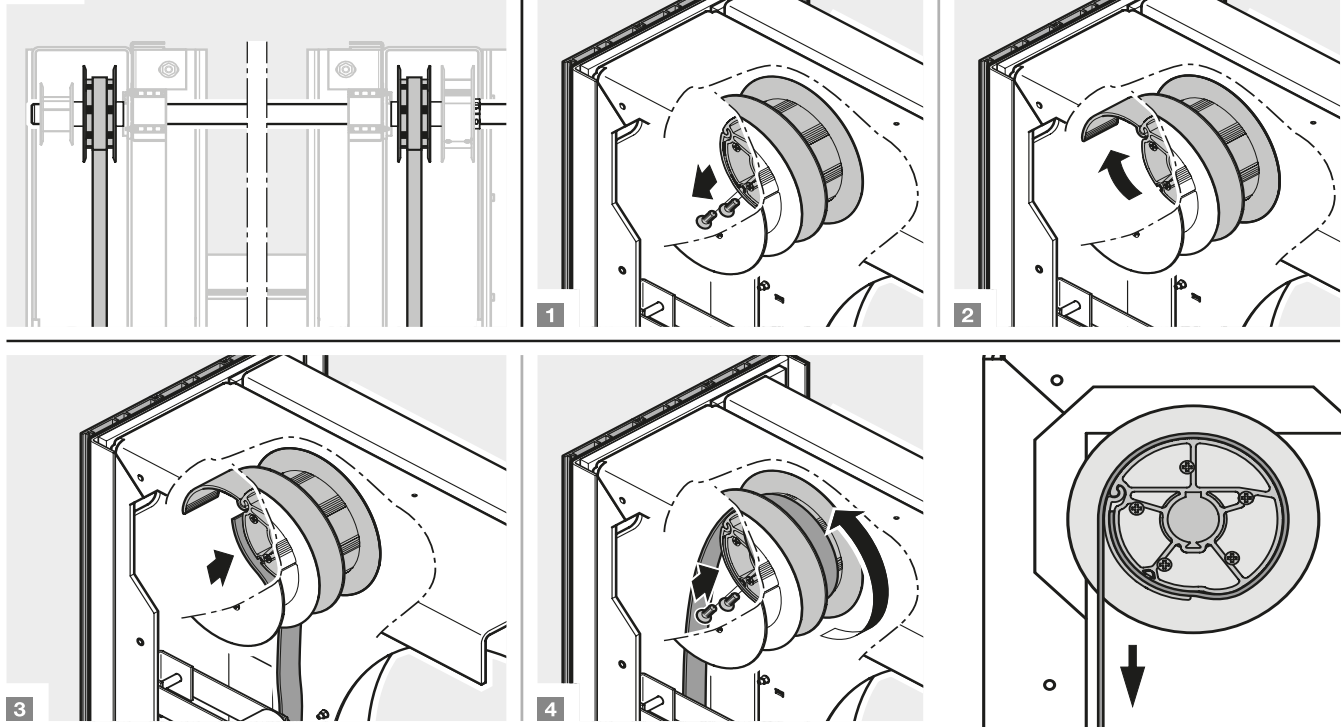

9.4

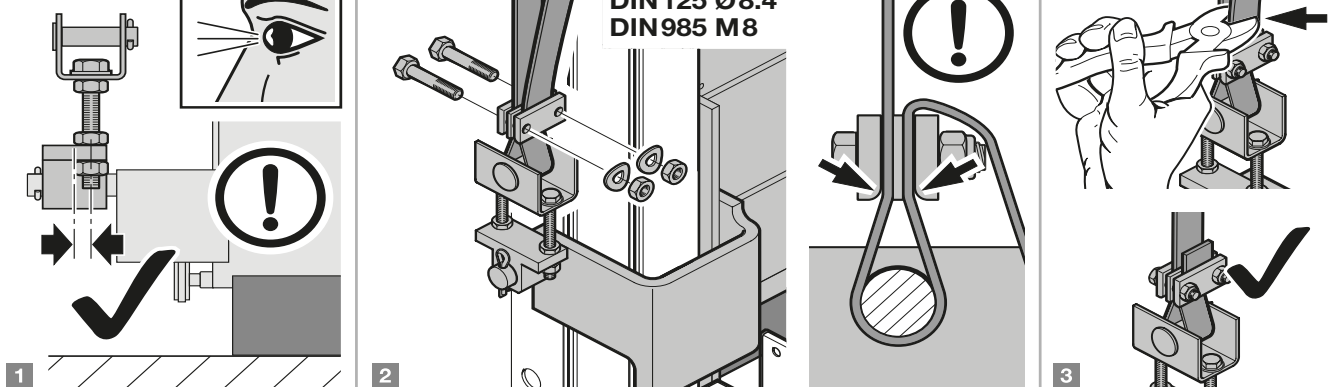

9.5

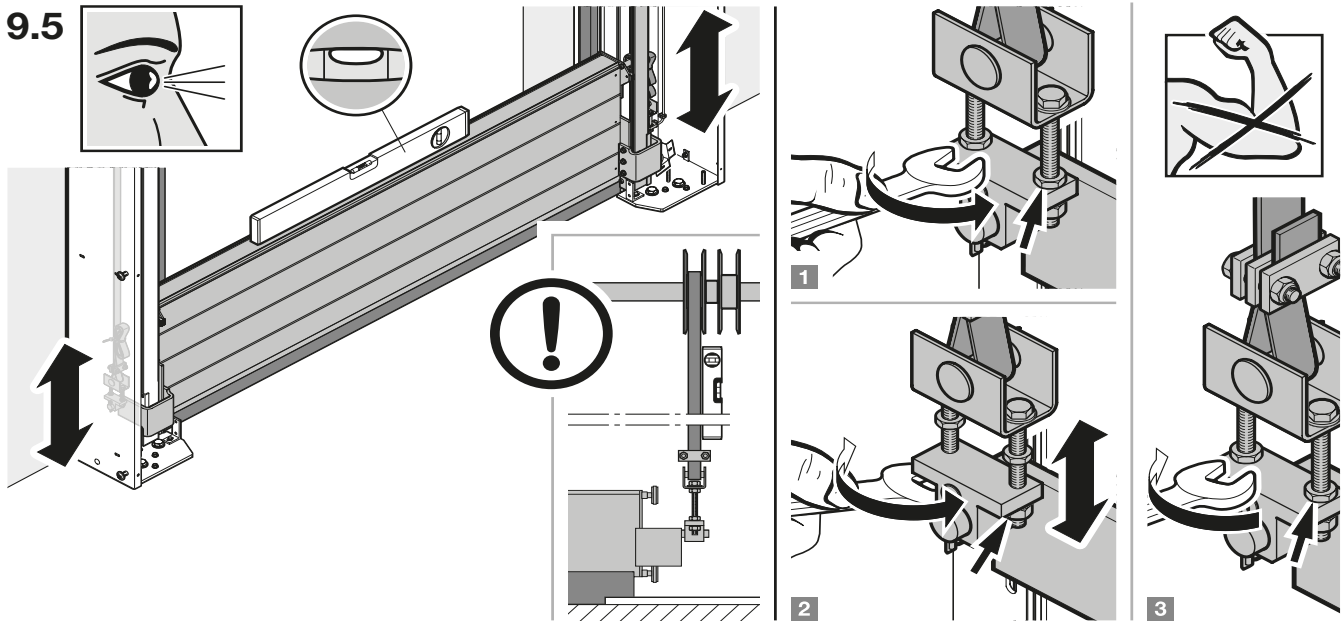

10

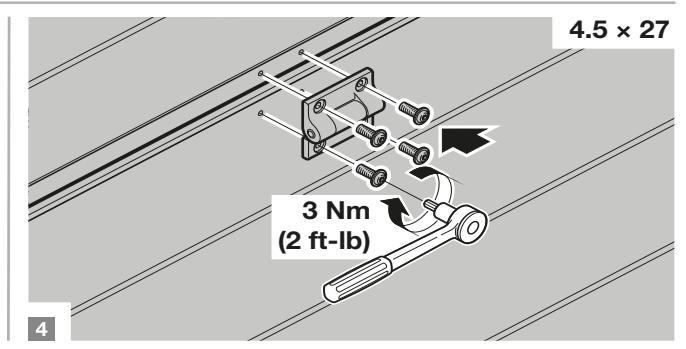
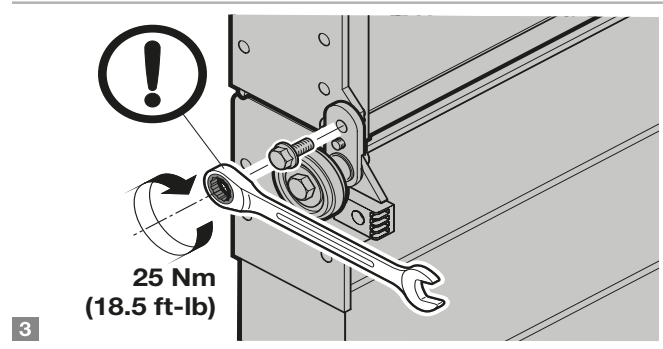
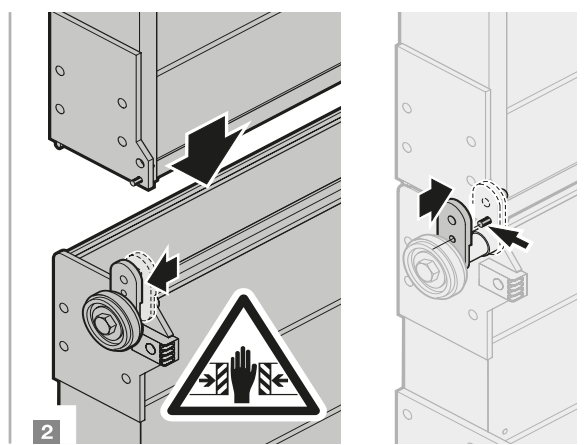
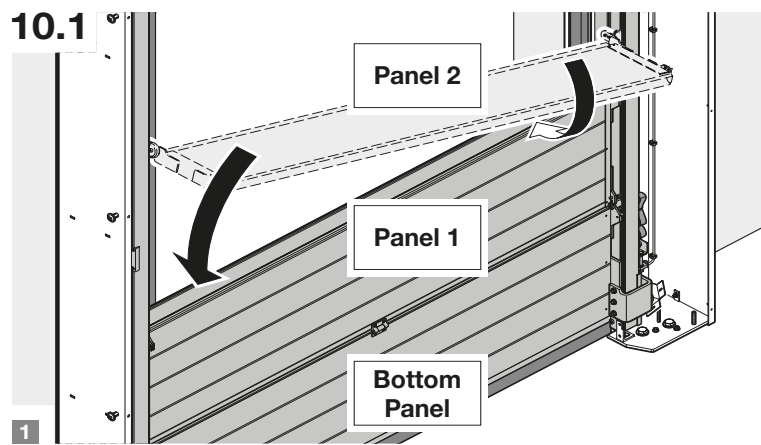
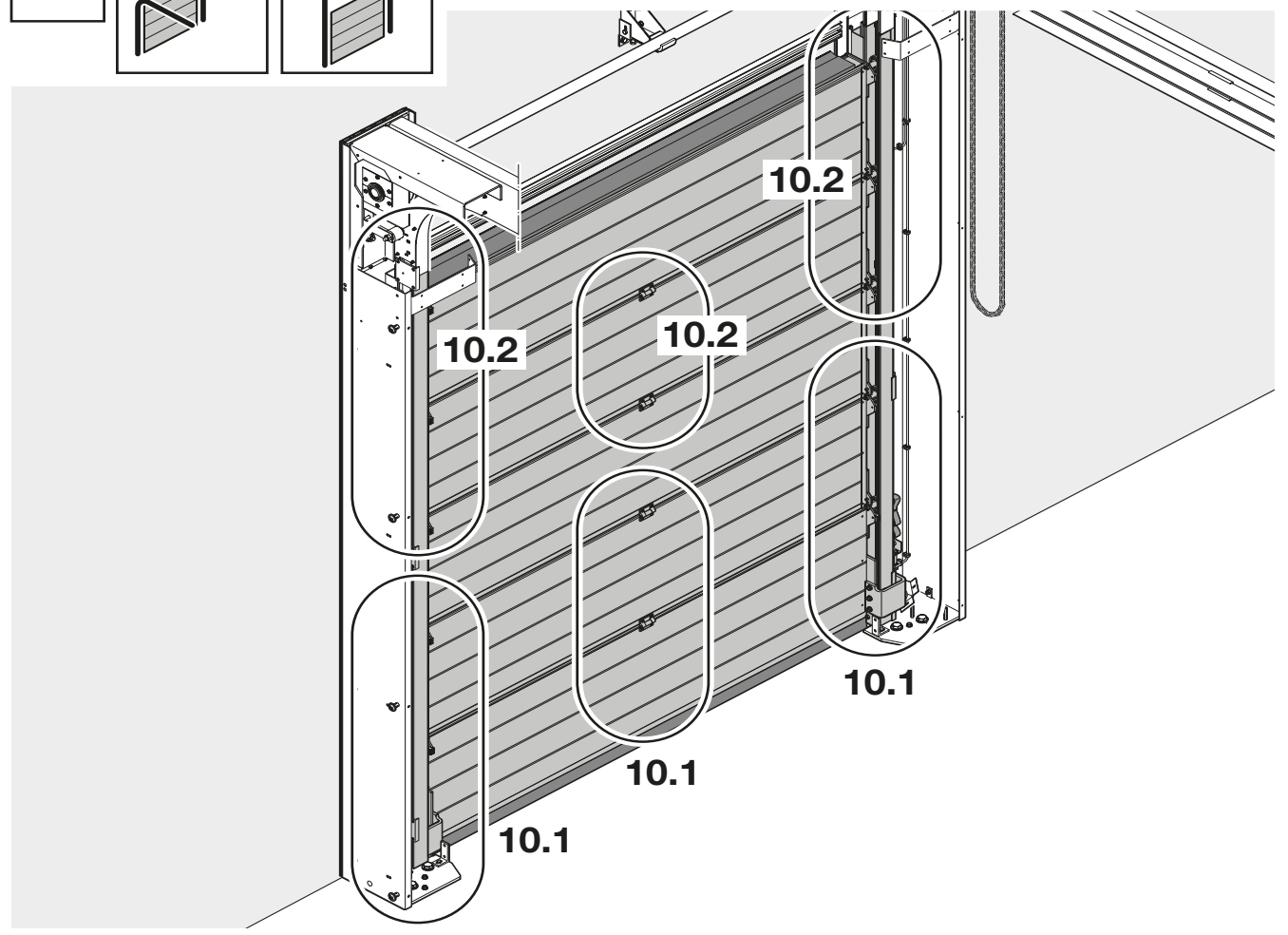
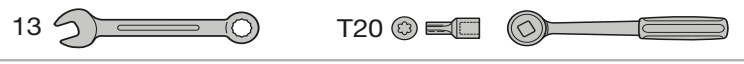
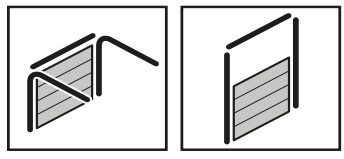

Attention: Do not stack more than the square footage of panels listed before the counterweights are installed. Failure to do so may damage the operator chain fall device.

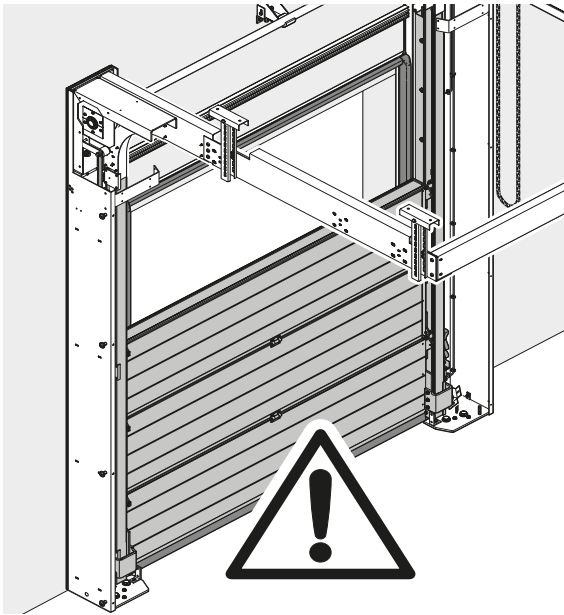

$DW \times DH \leq 25 \text{ m}^2 (269 \text{ ft}^2)$

→ 10.2 | 11 | 12 | 13

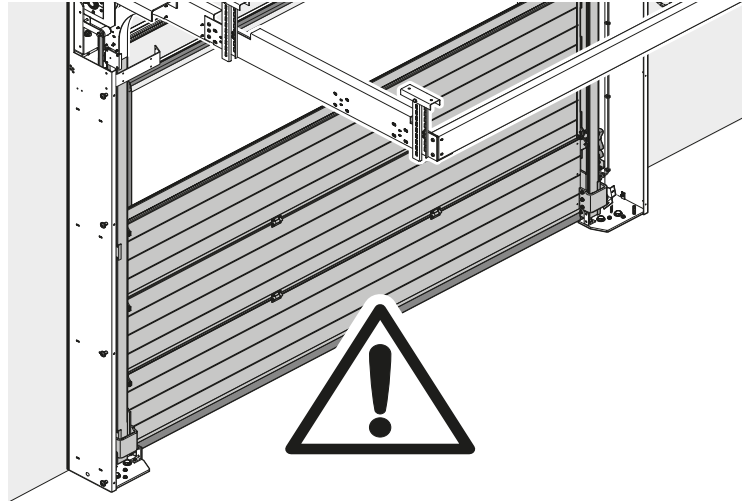

$DW \times DH > 25 \text{ m}^2 (269 \text{ ft}^2)$

→ 11 | 10.2 | 12 | 13

10.2

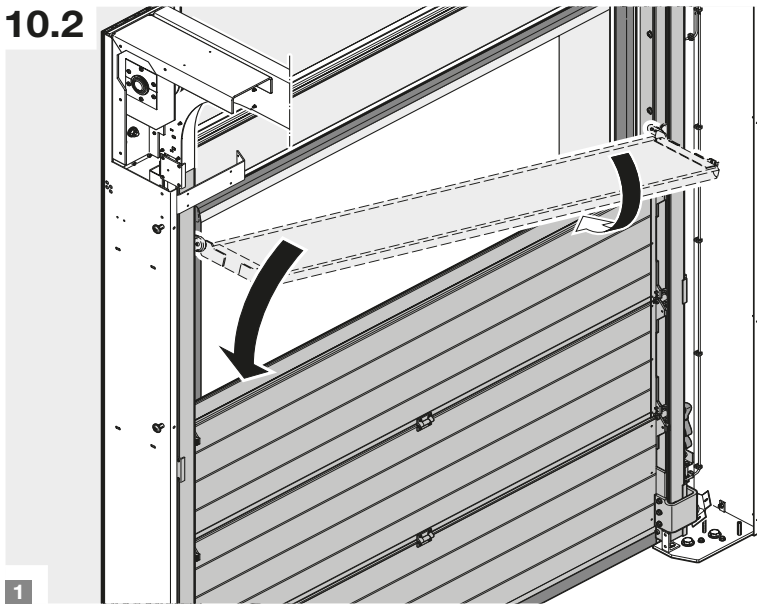

1

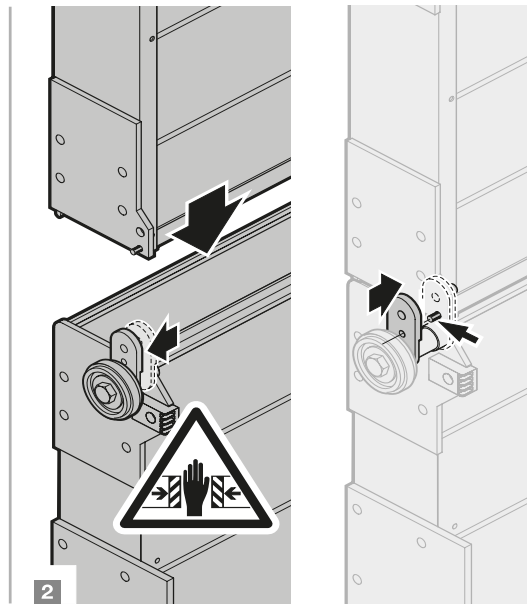

2

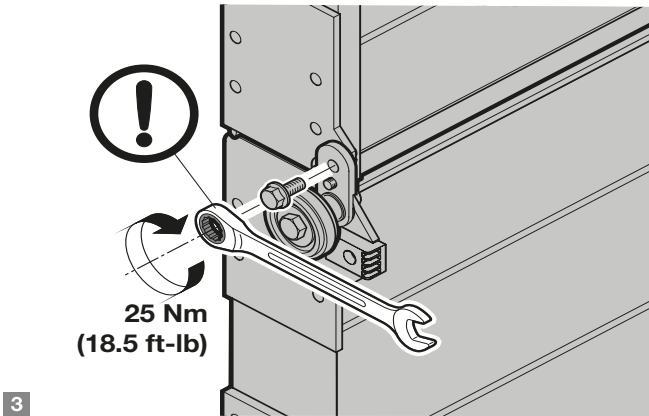

3

! 25 Nm (18.5 ft-lb)

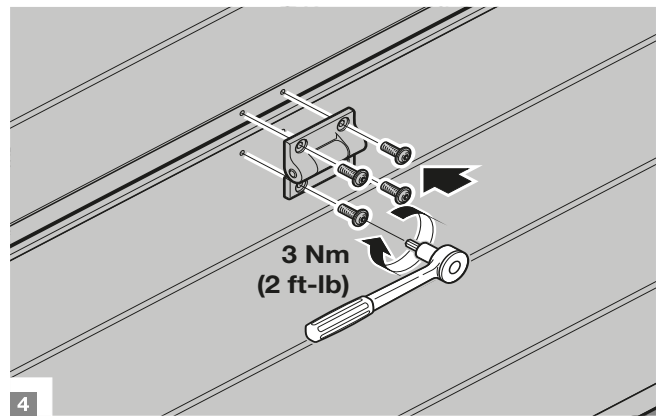

4

3 Nm (2 ft-lb)

11

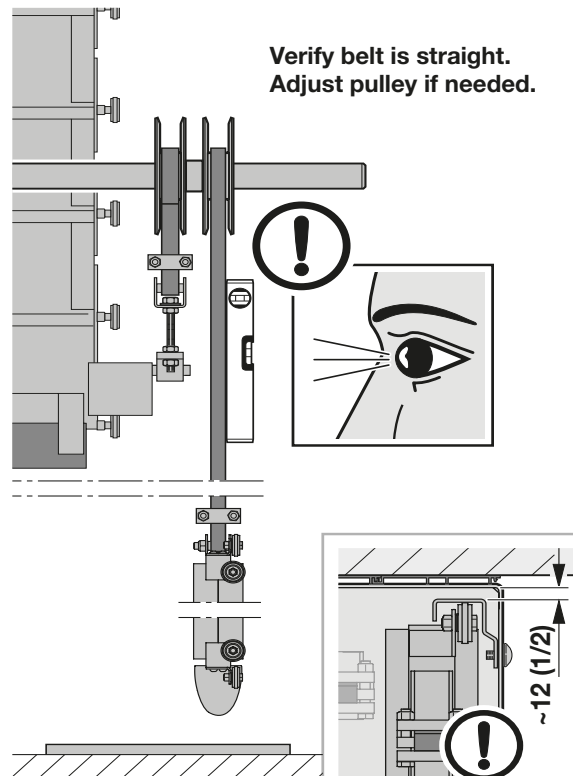
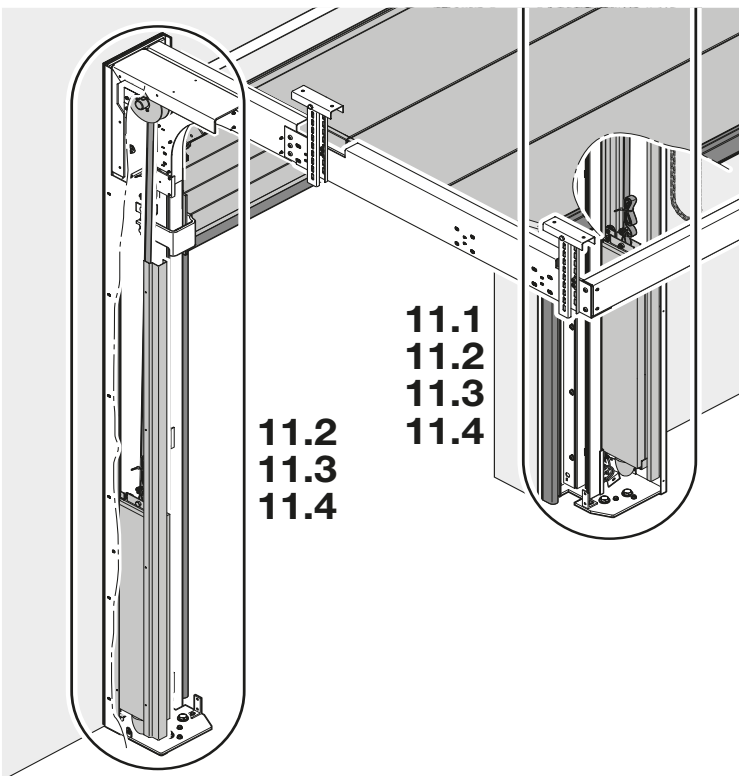
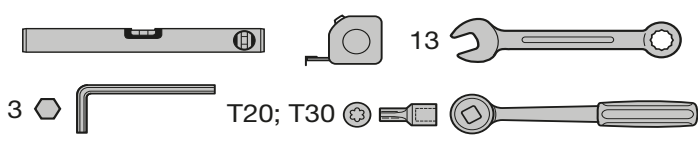
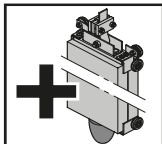
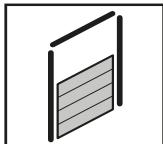
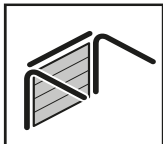

11.1



10.2

Bottom Panel + Panel 1 + ...
...+ Panel N ≤ 25 m² (269 ft²)

1

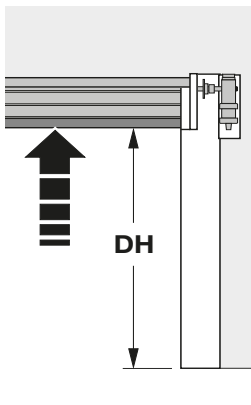
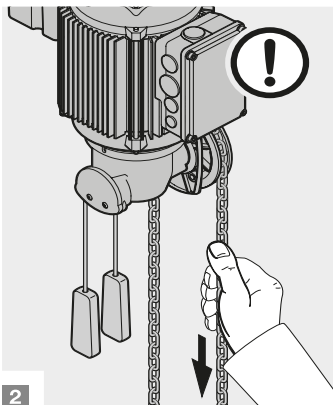
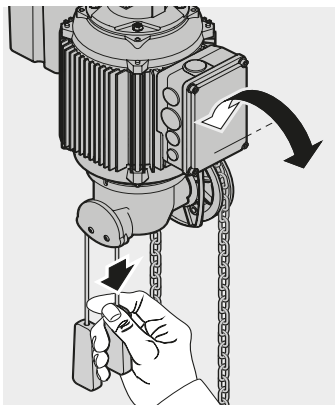

11.2

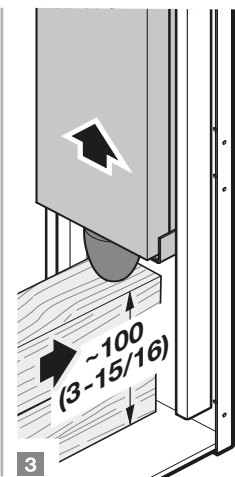
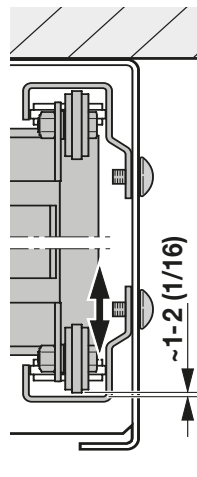
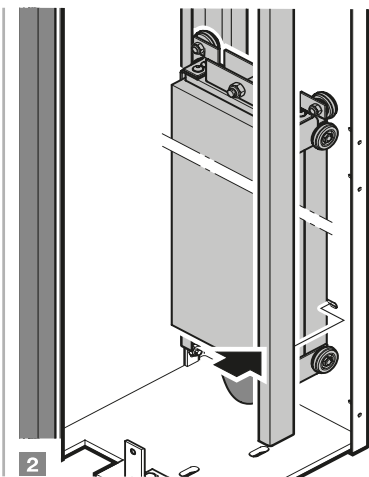
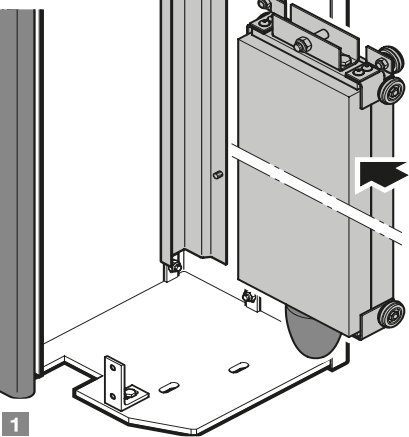

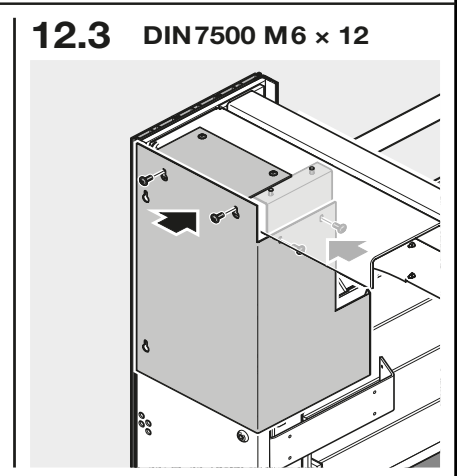
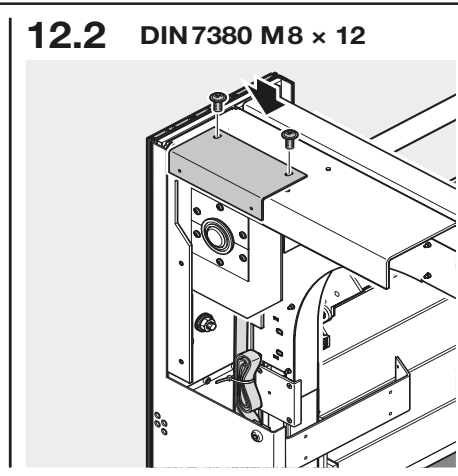
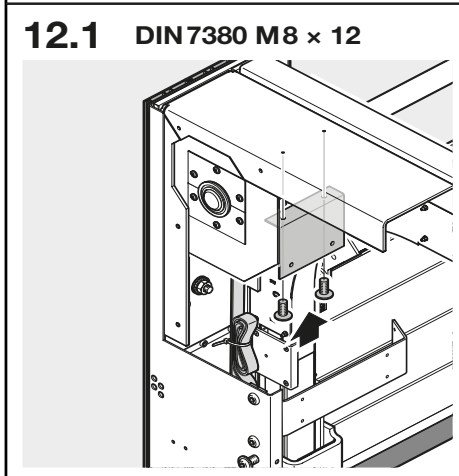
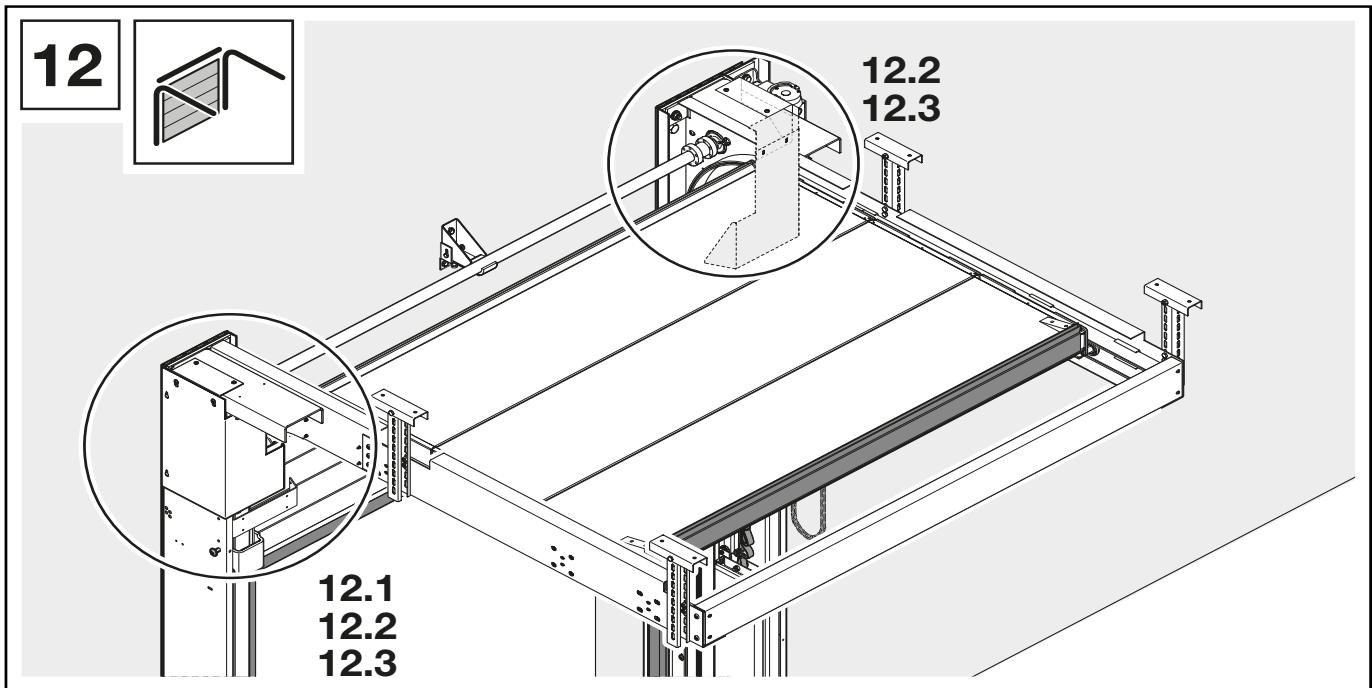
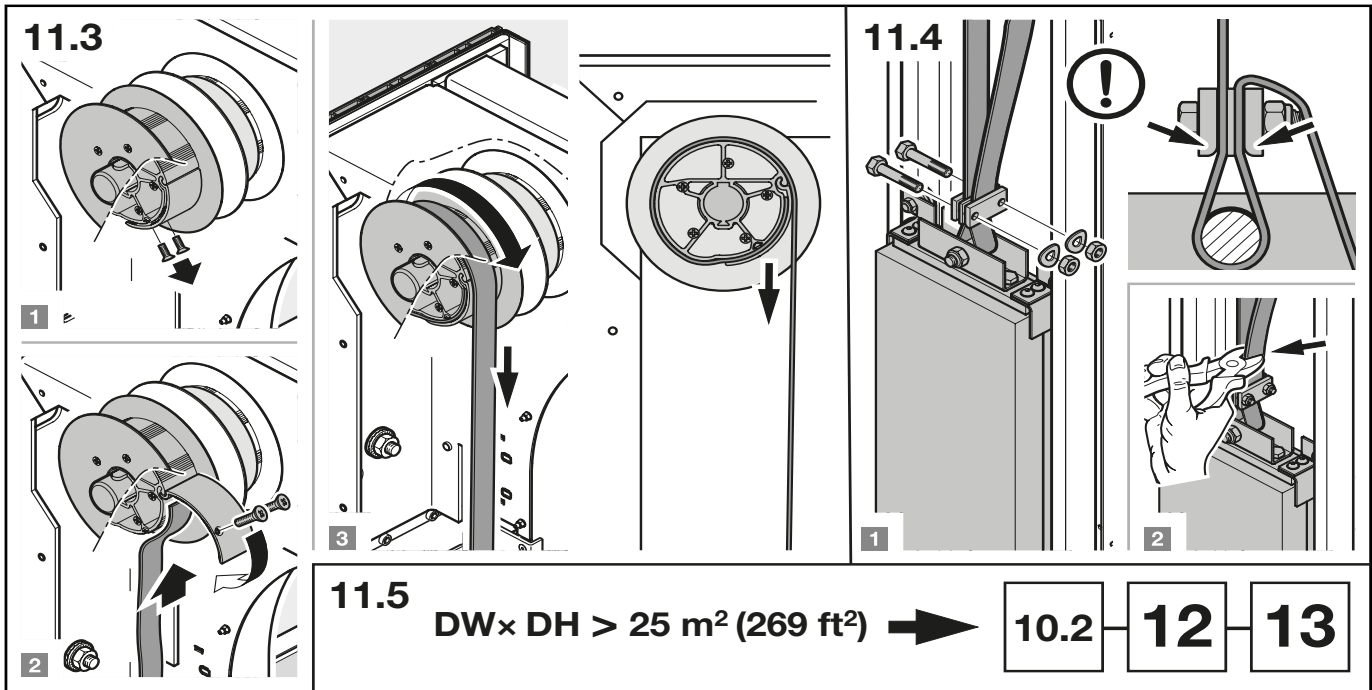

13

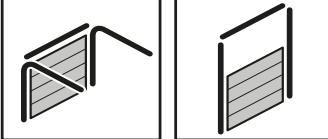

- 3
- 7; 13
- T30

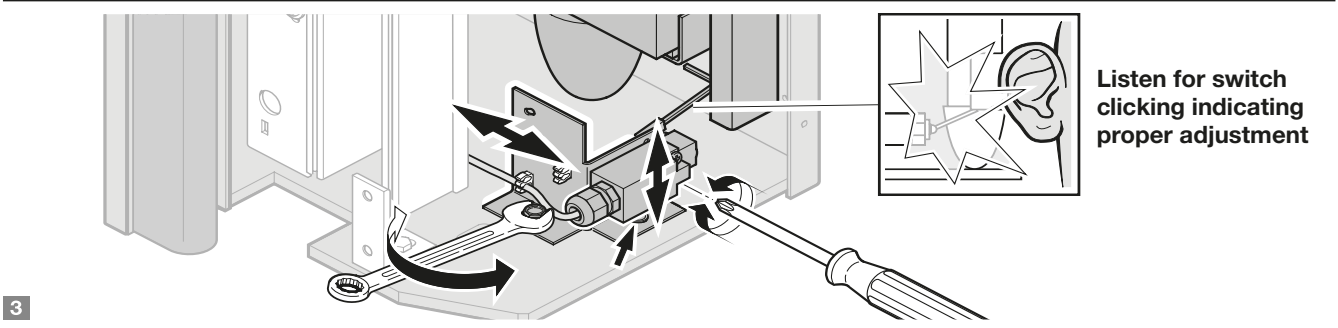
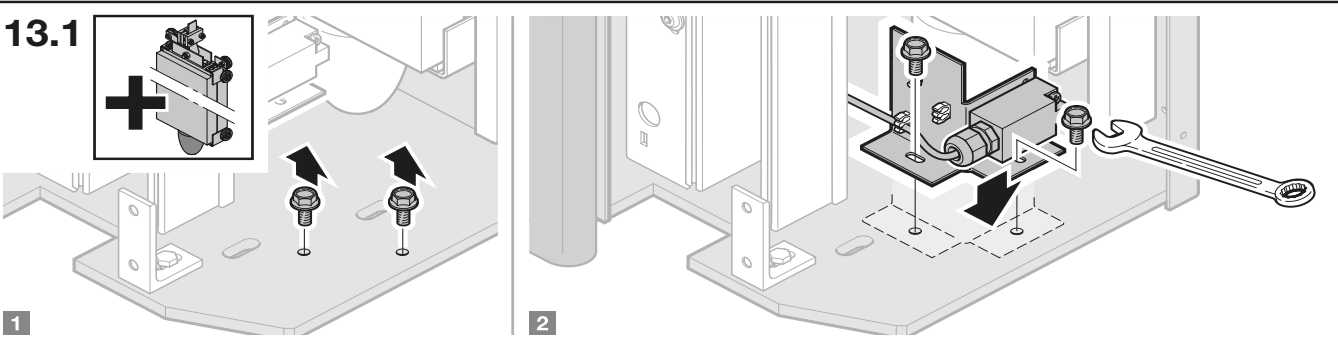
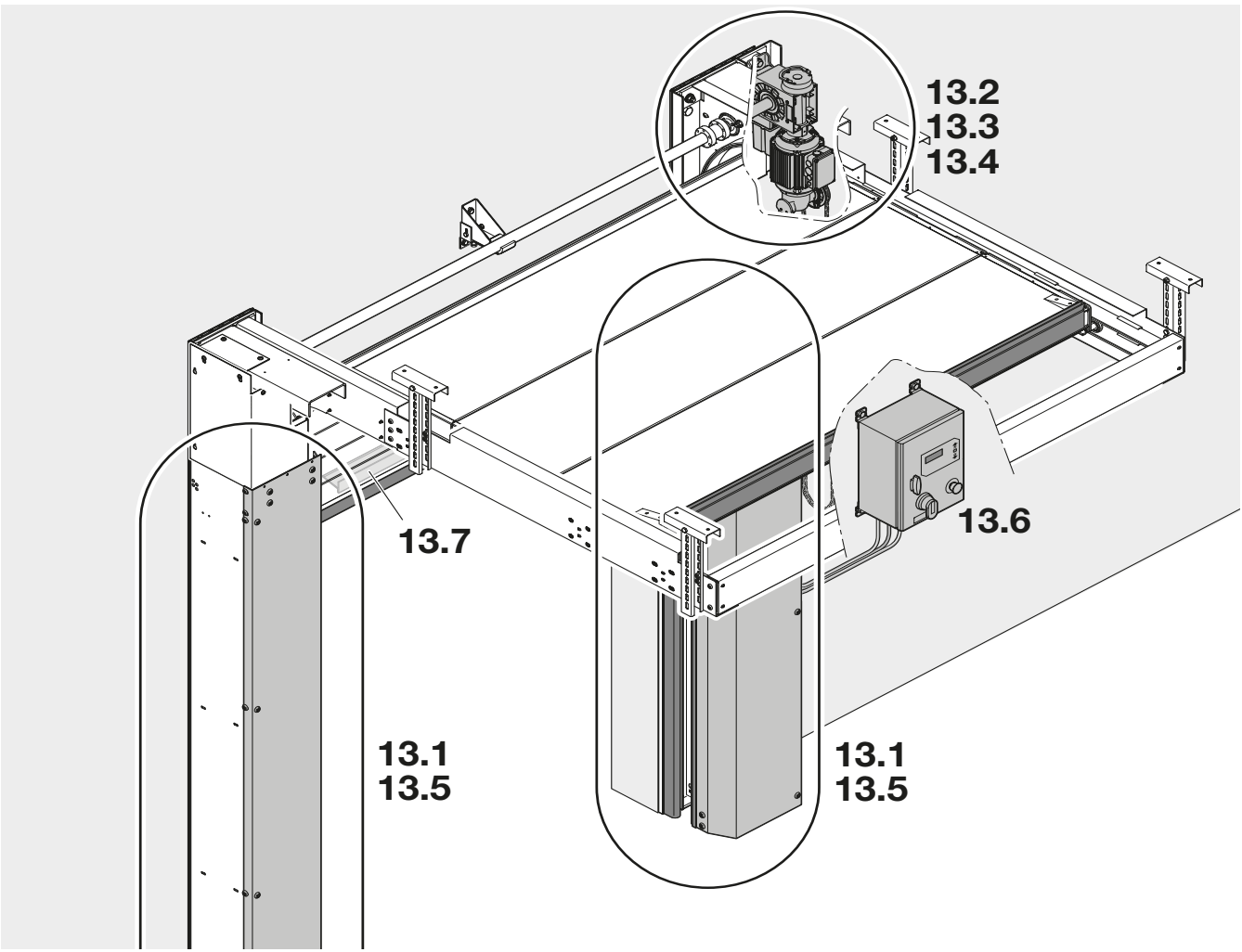

13.2

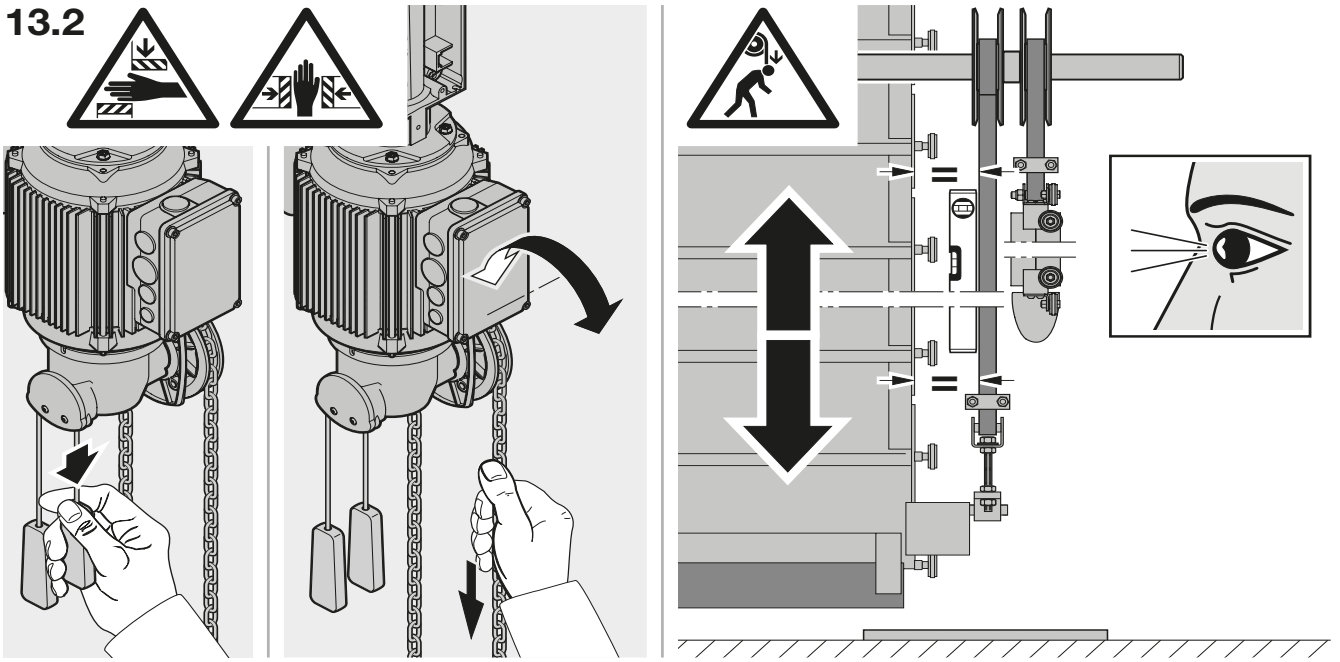

13.3

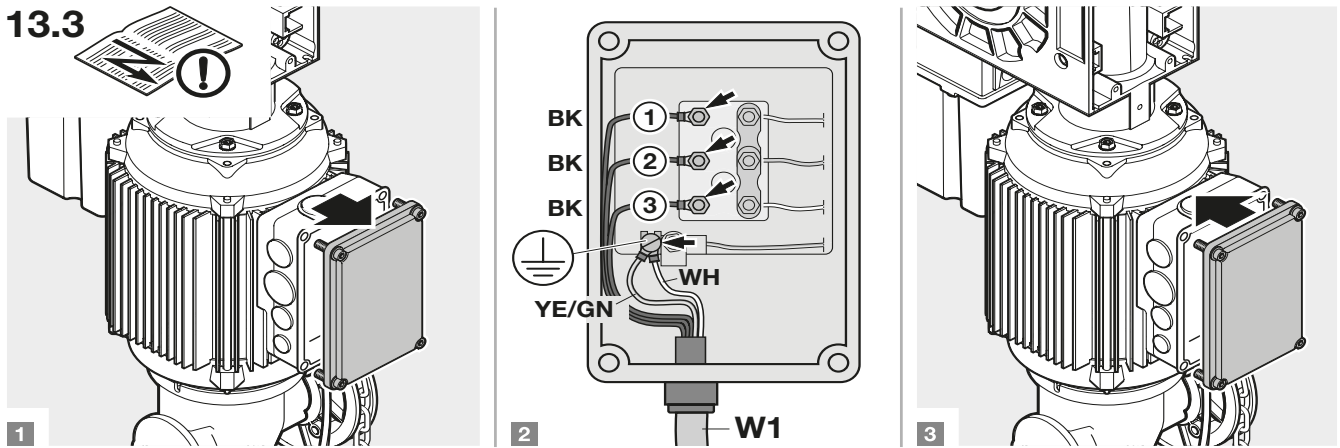

13.4

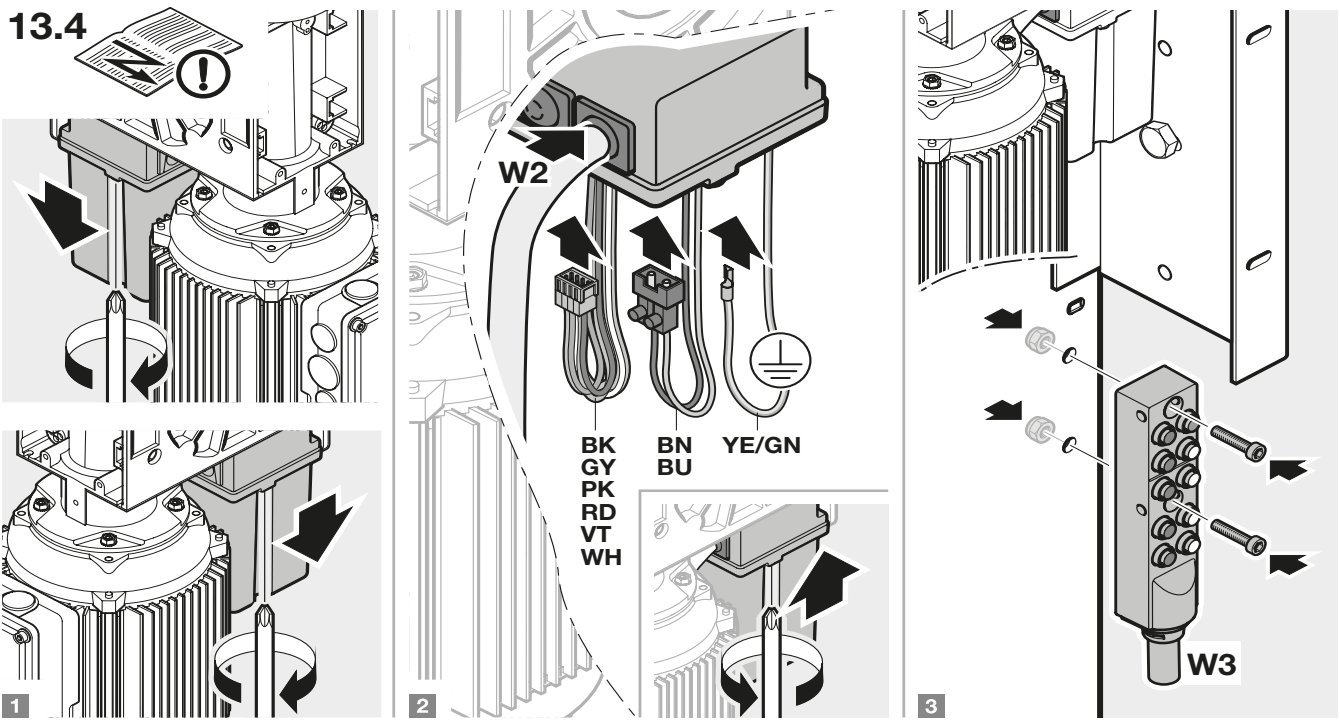

13.5

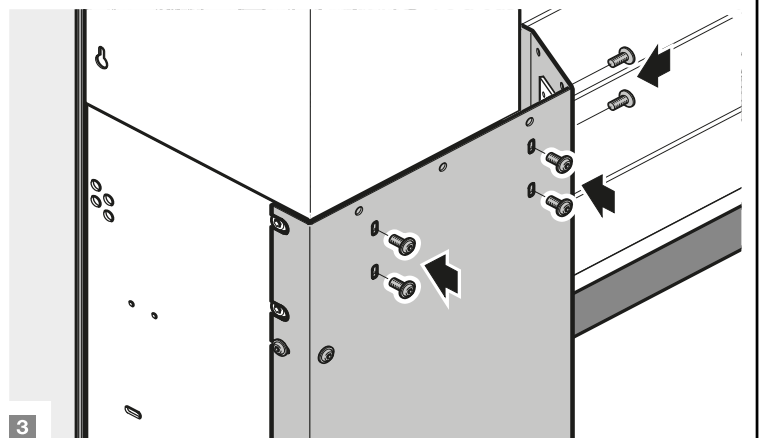
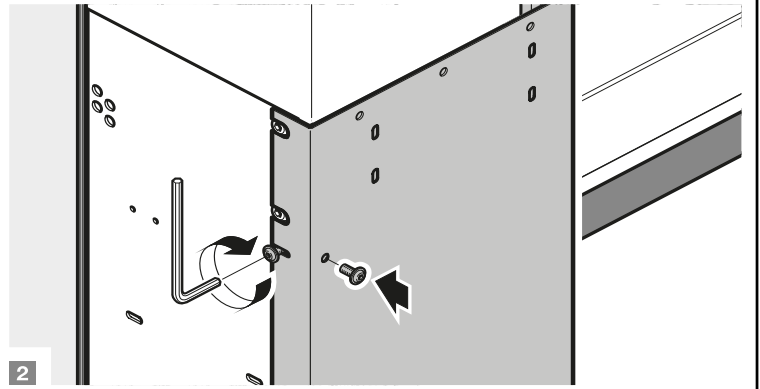
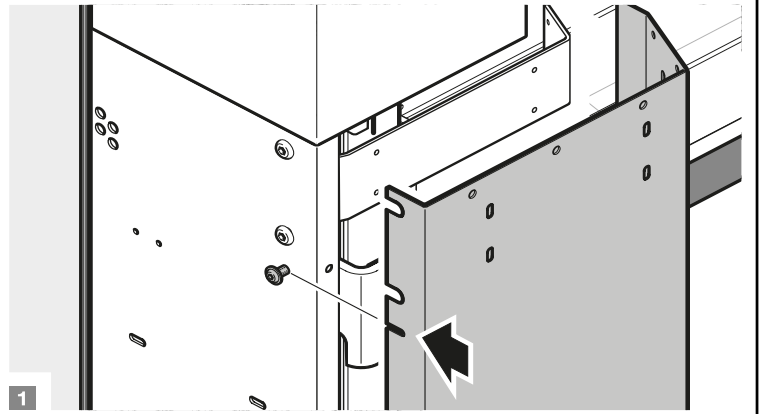
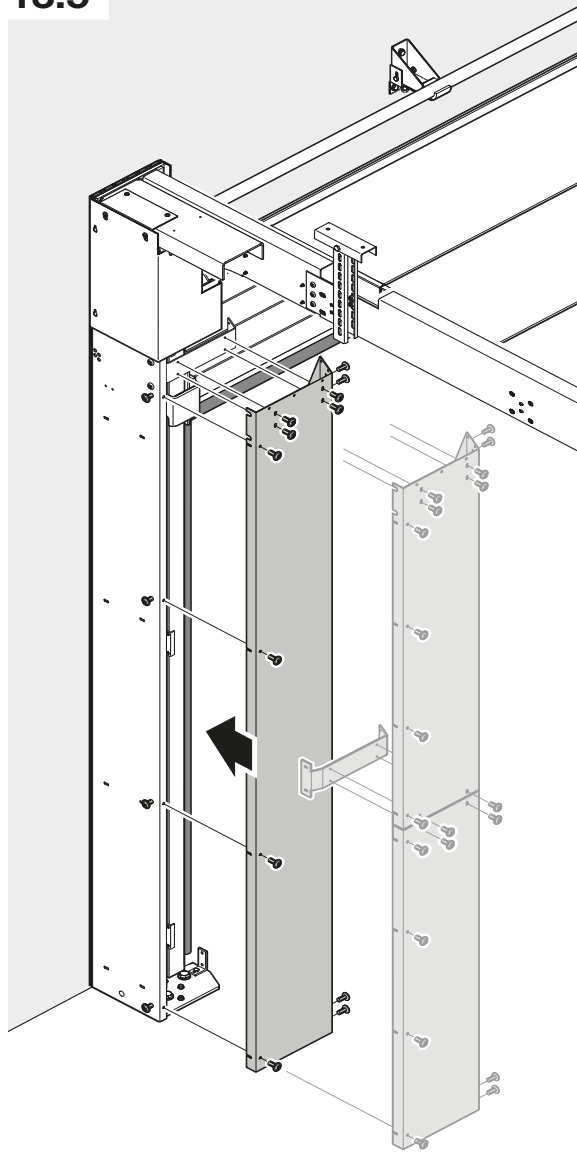

13.6

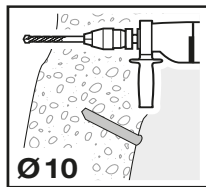

DIN571 8 x 50
S 10

Hardware by
others

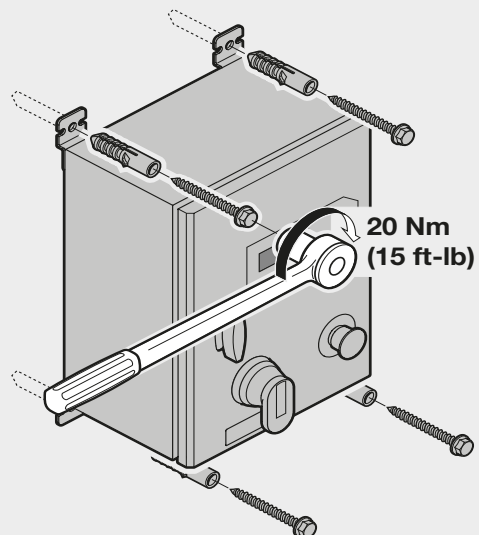

13.7

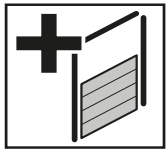

~1500 mm
(~59 1/6)

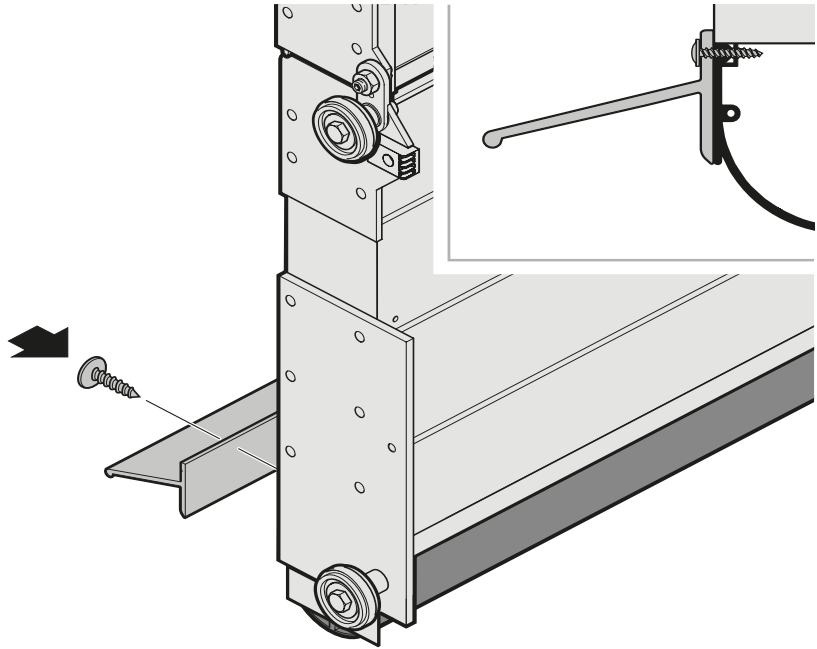

13.8

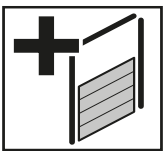
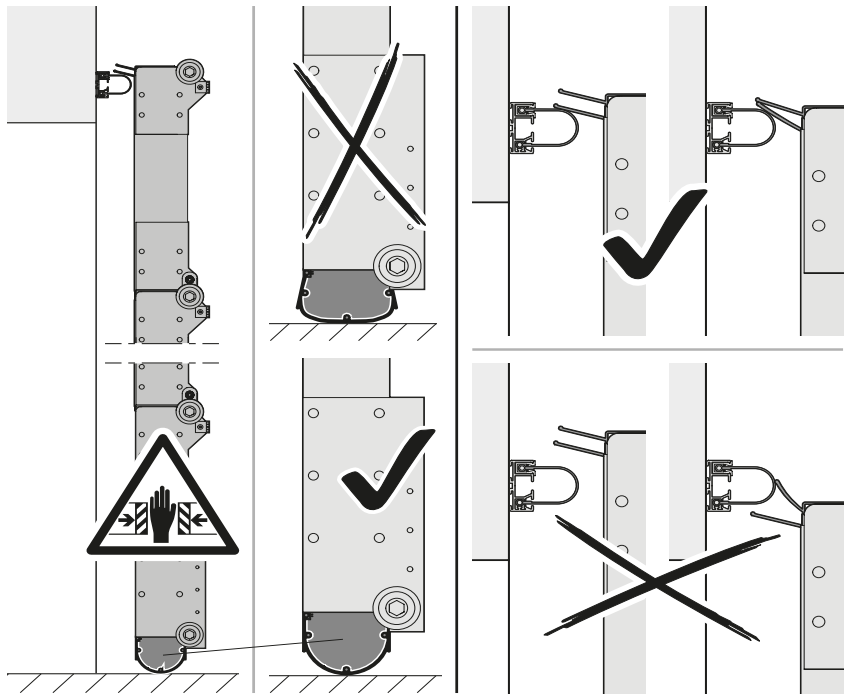

DH

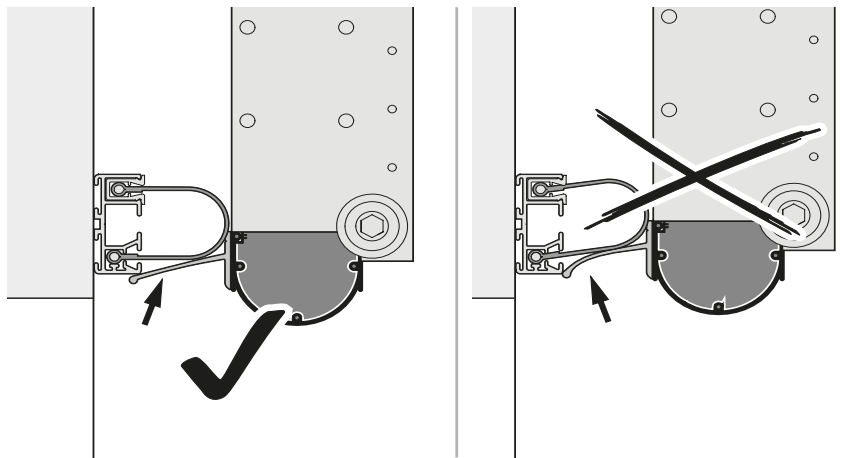

14

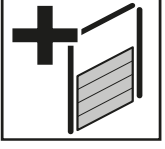

T30

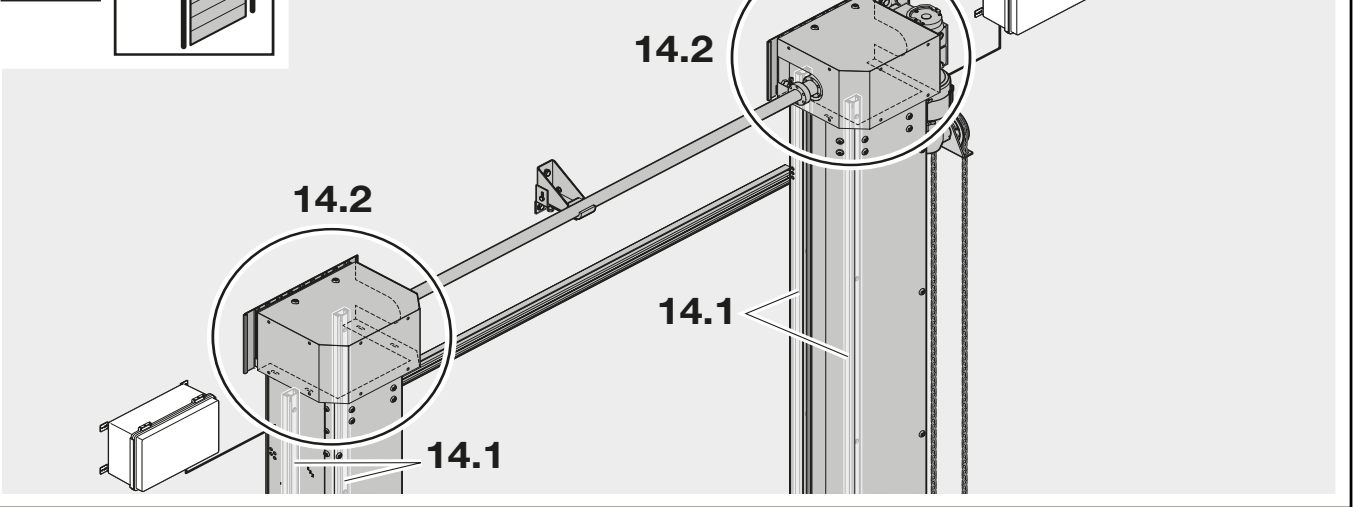

14.1

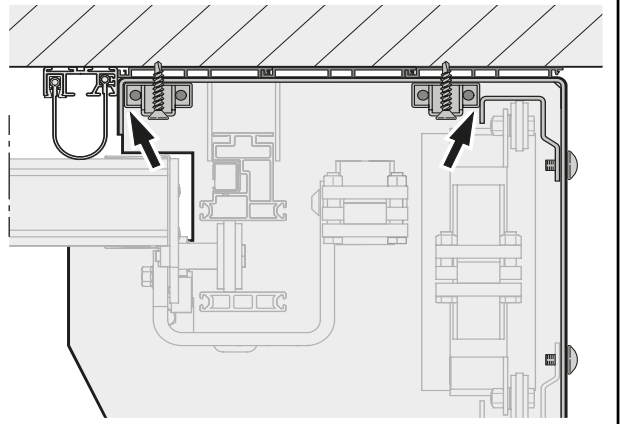
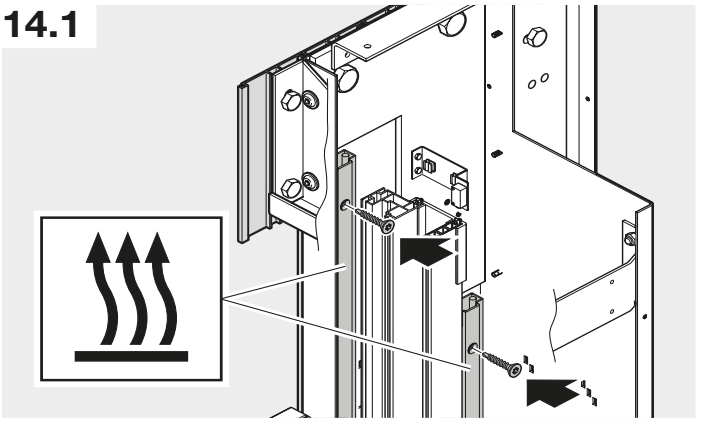

14.2

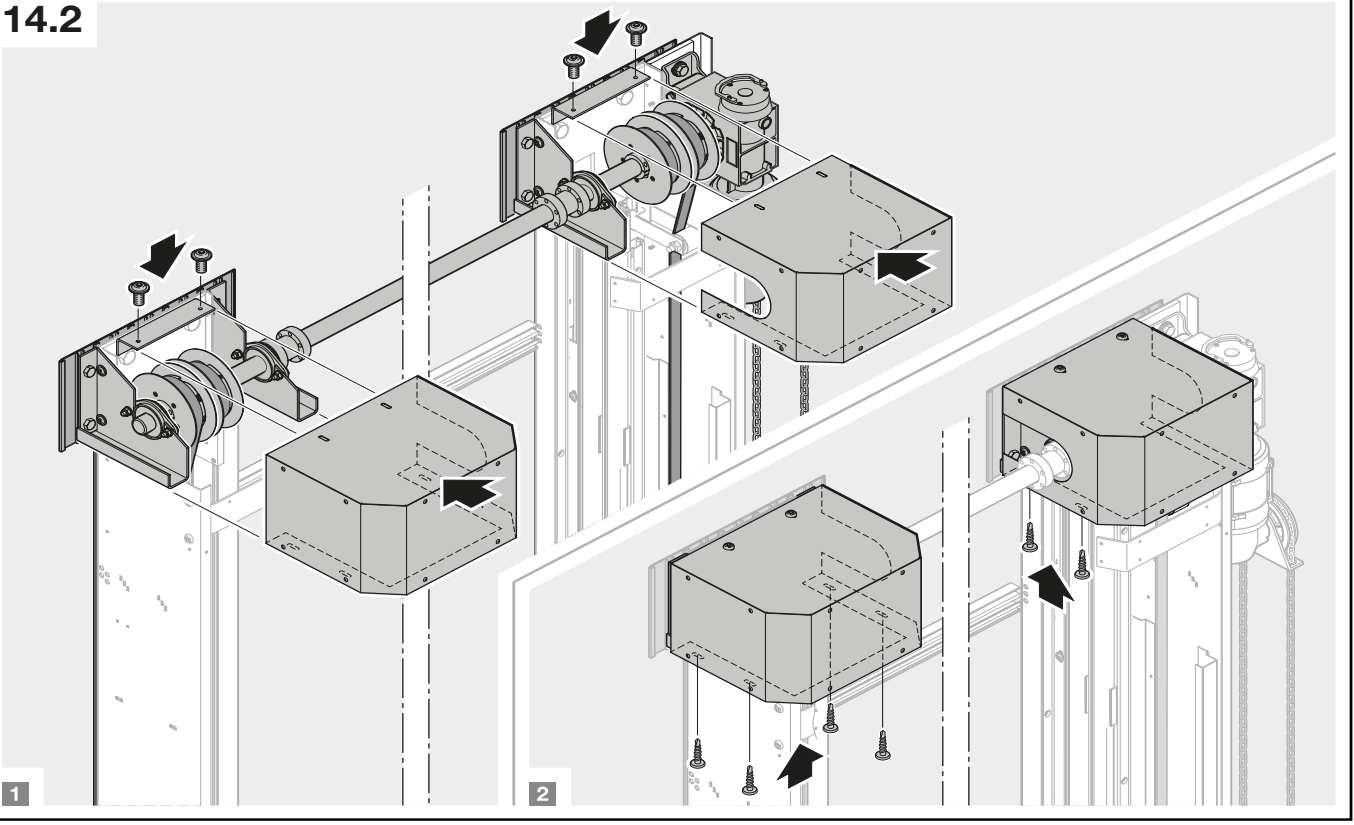

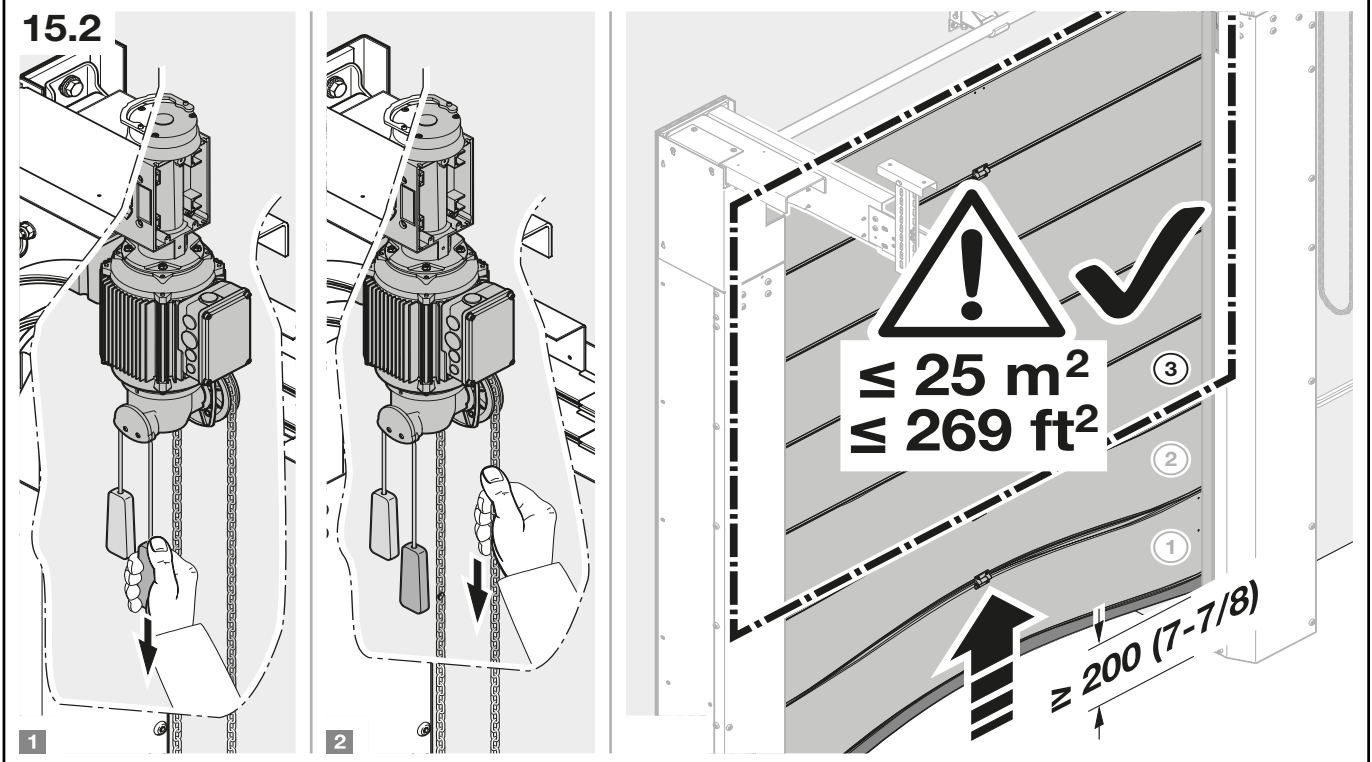
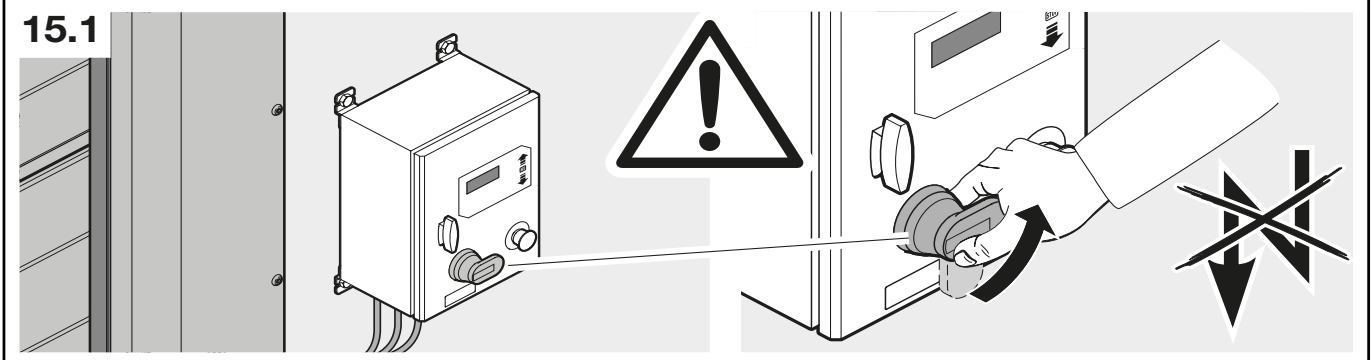
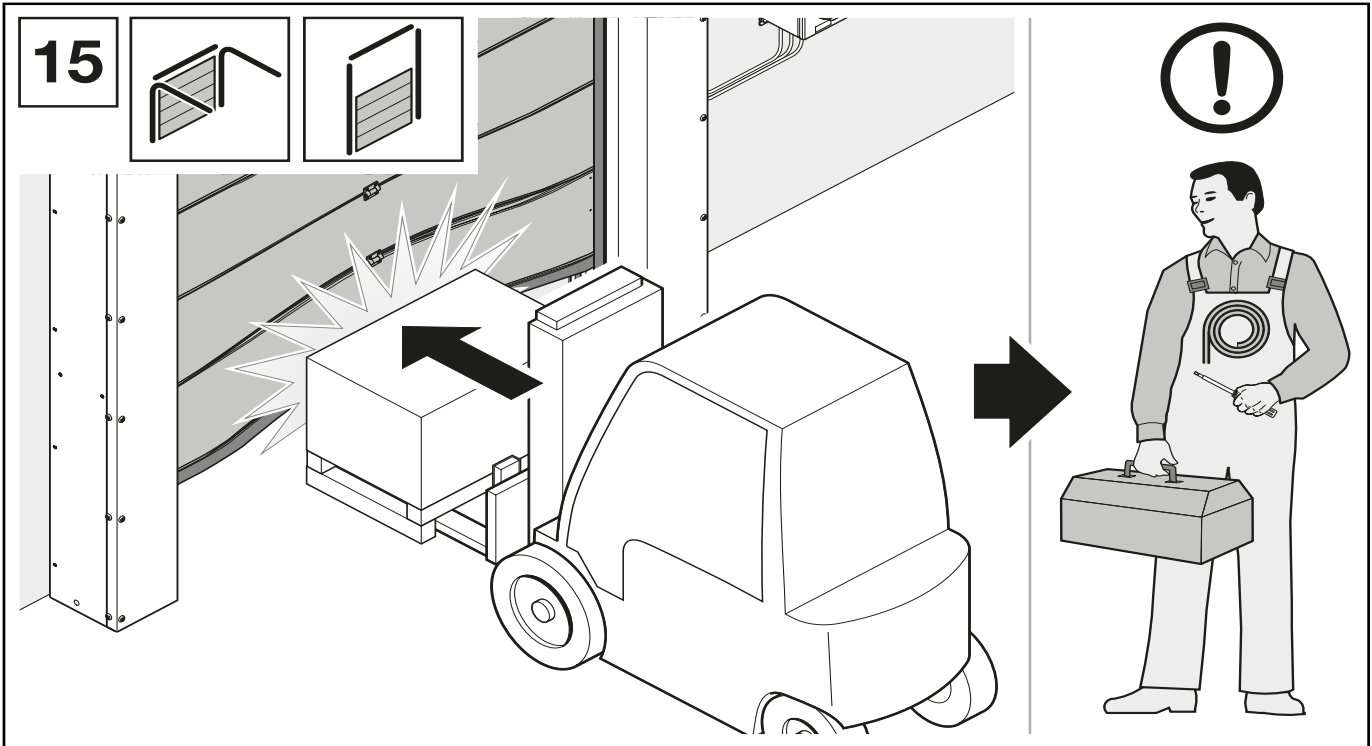

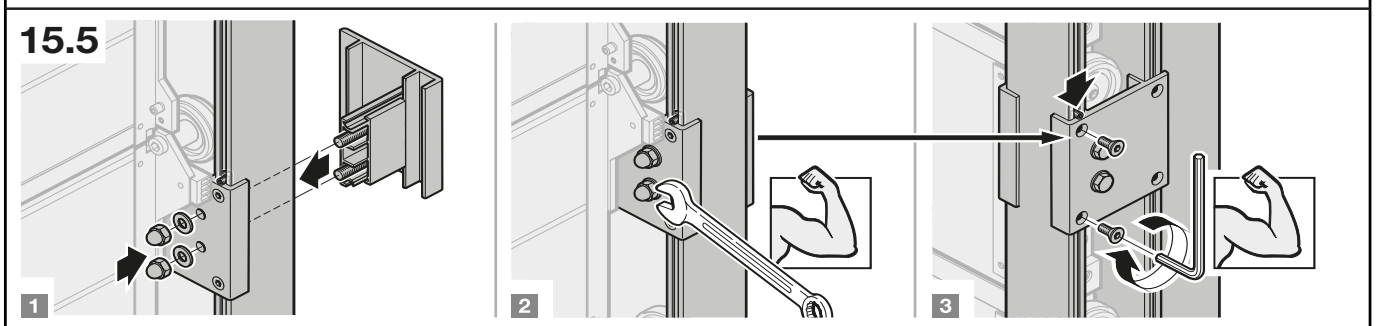
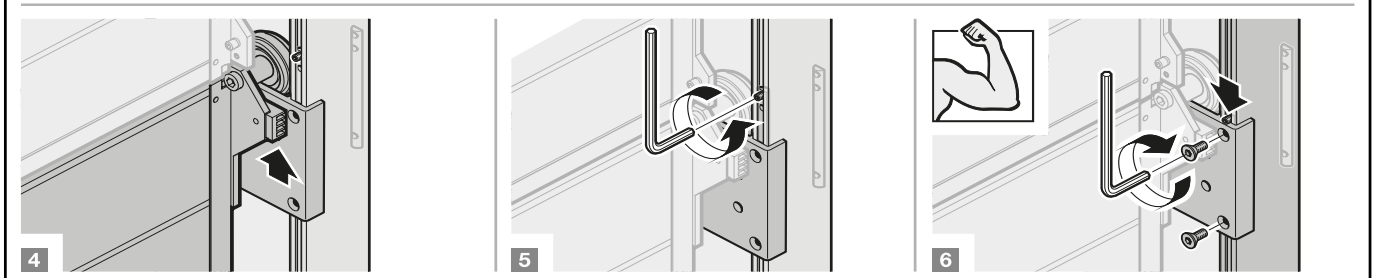
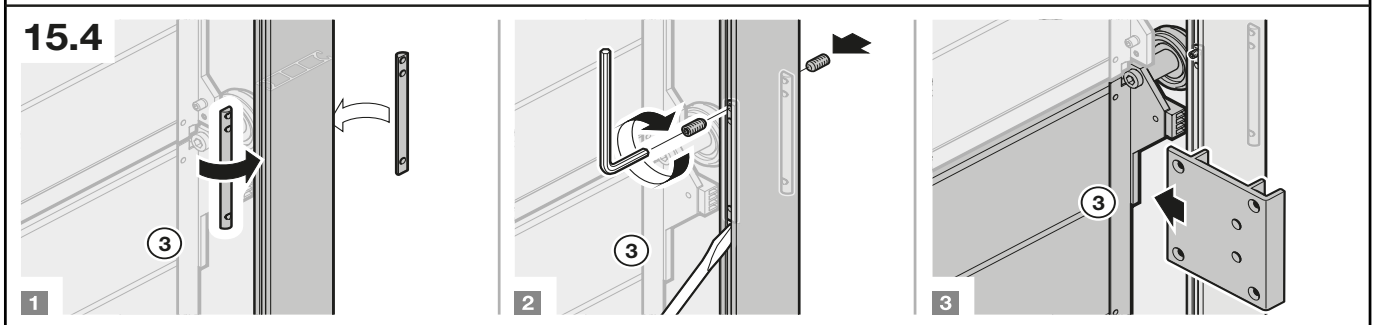
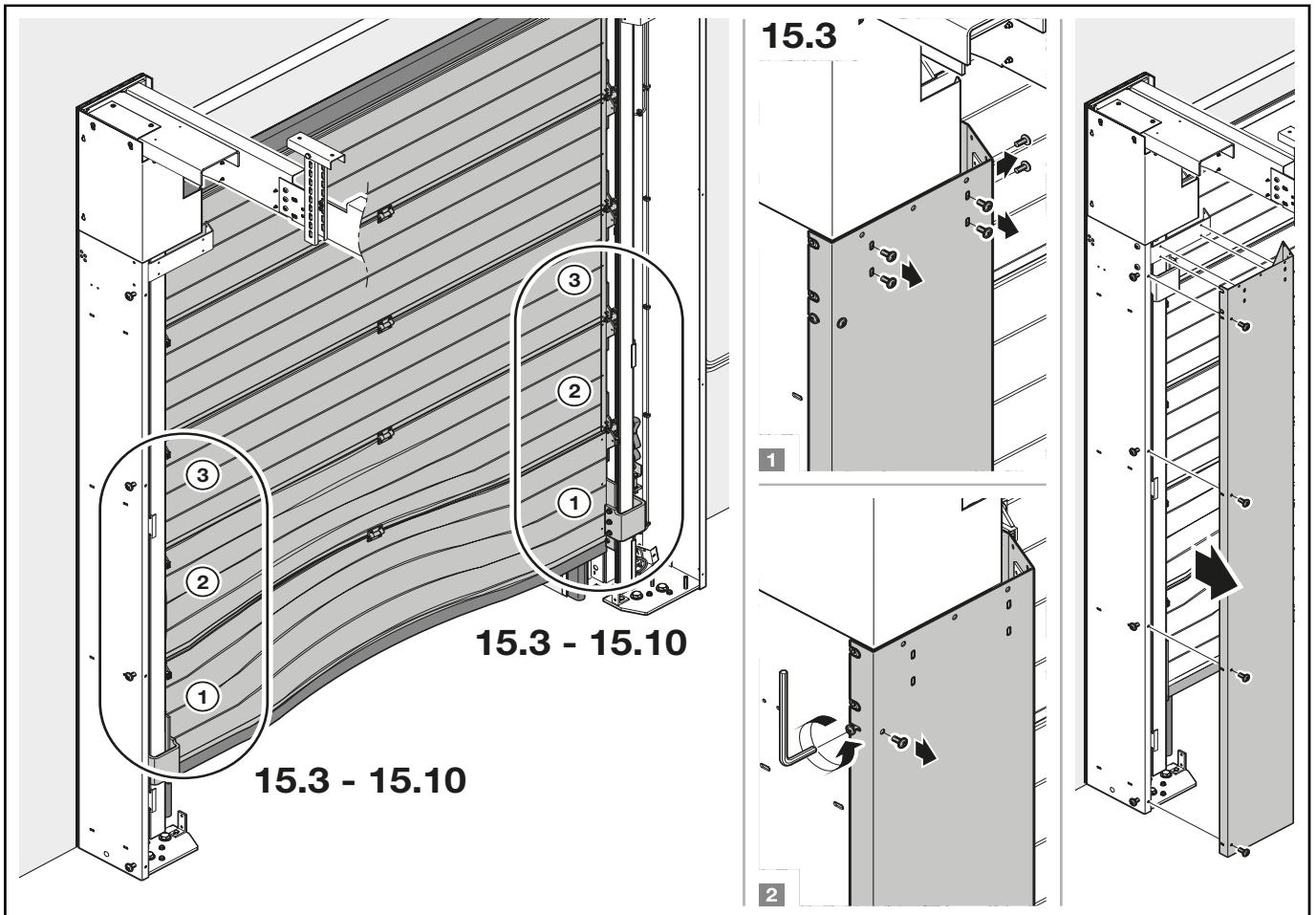

15.6

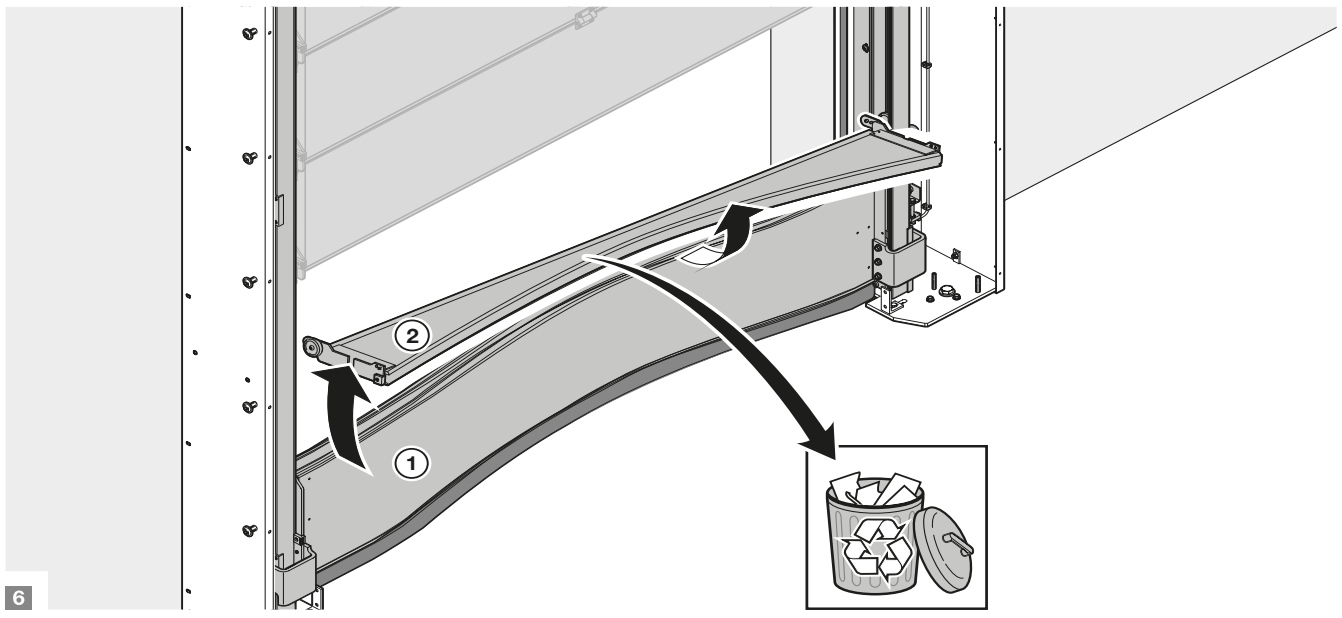
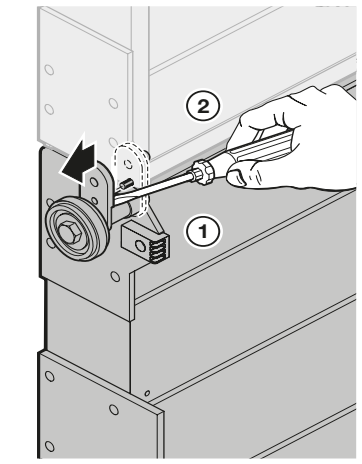
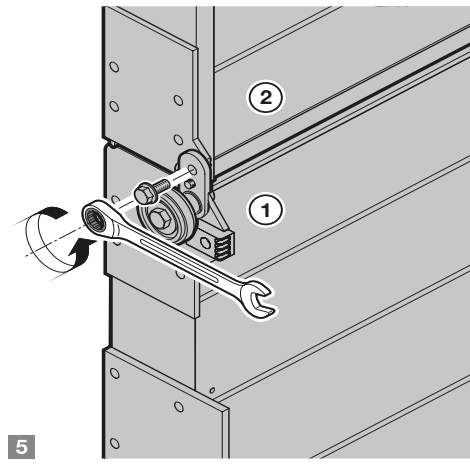
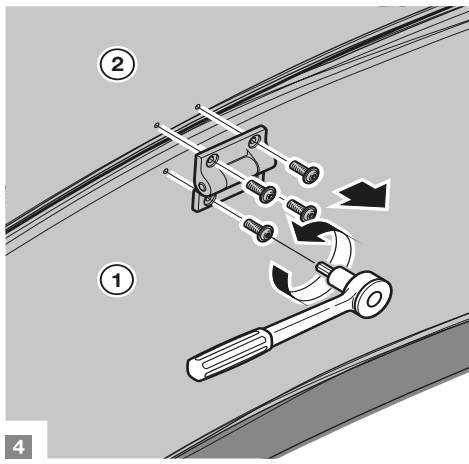
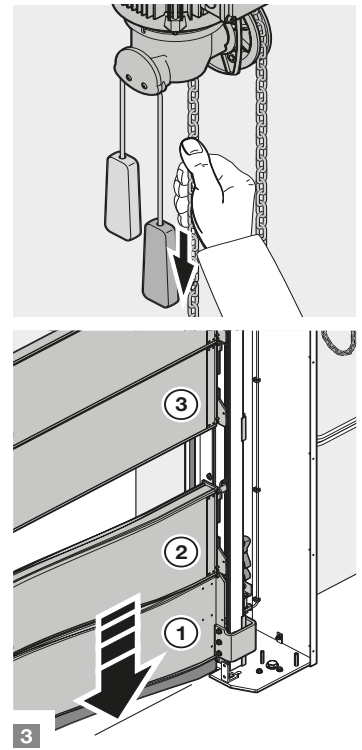
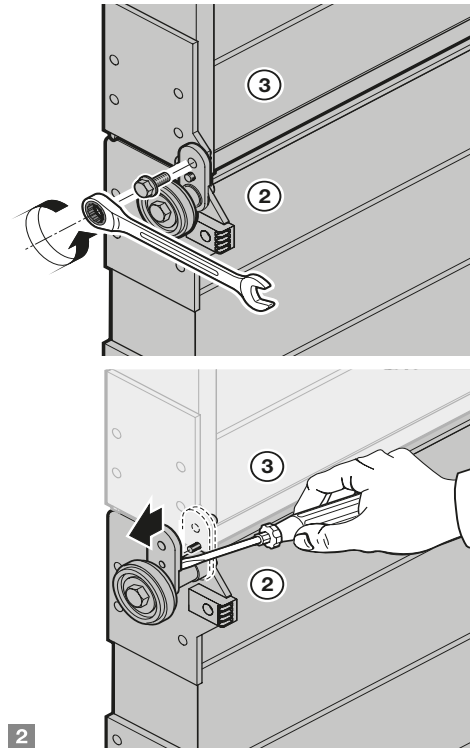
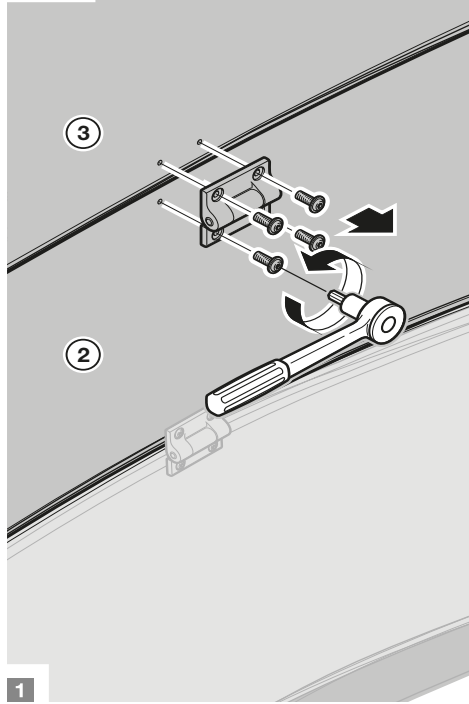

15.7

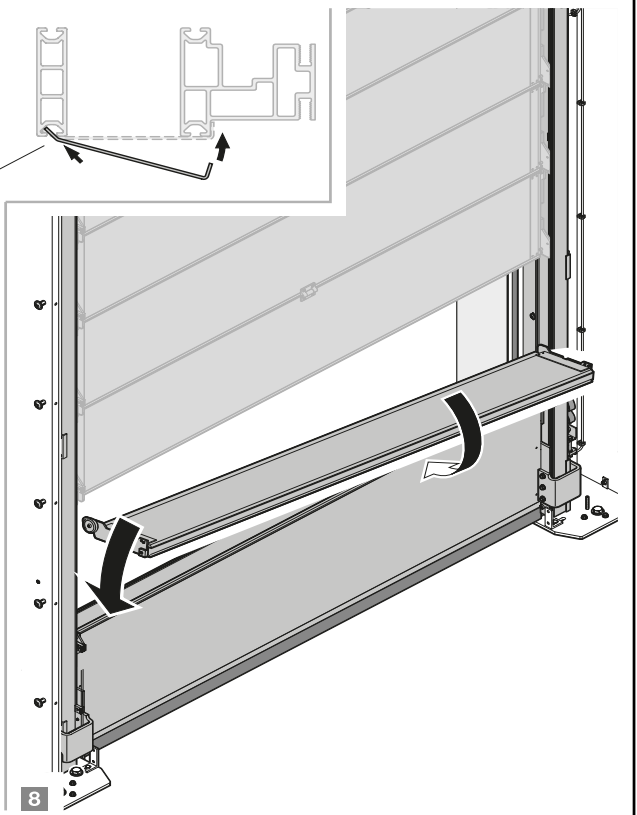
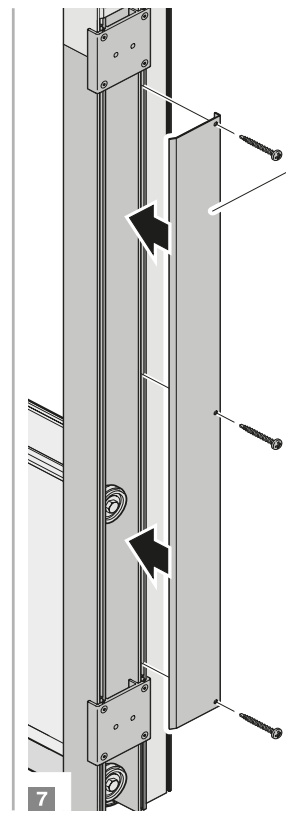
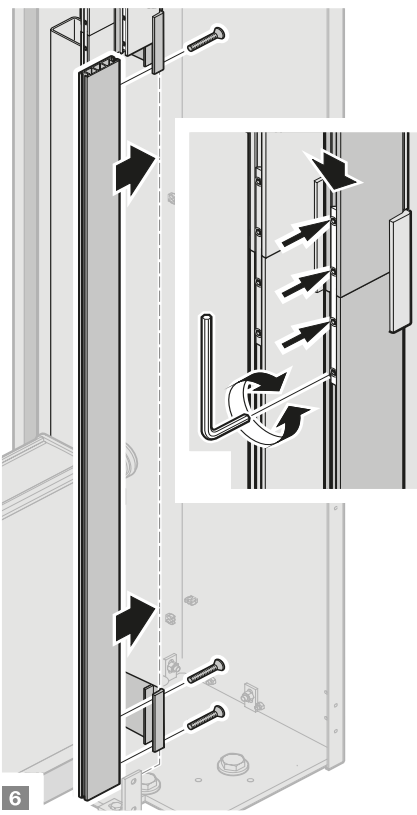
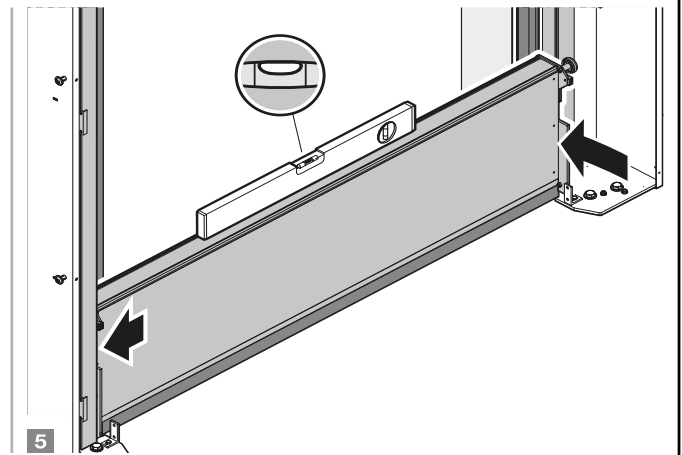
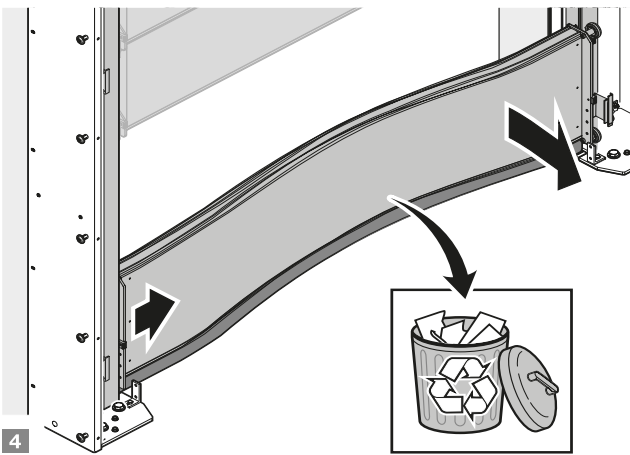
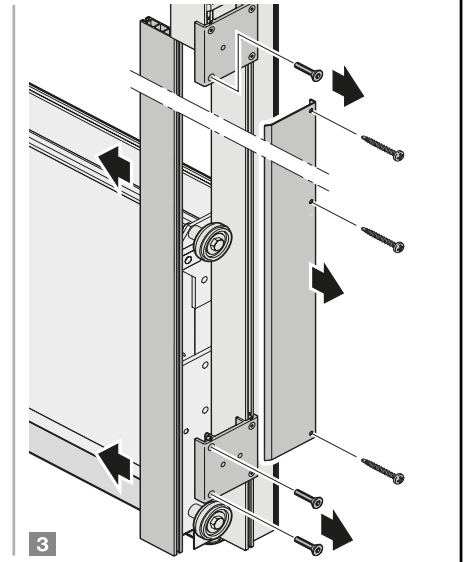
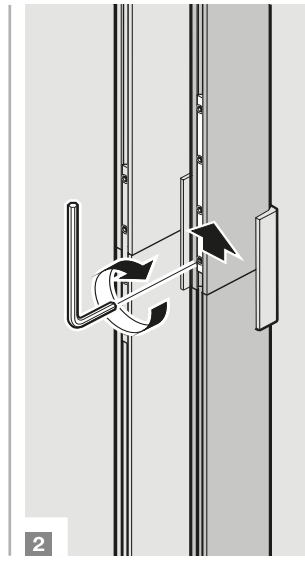
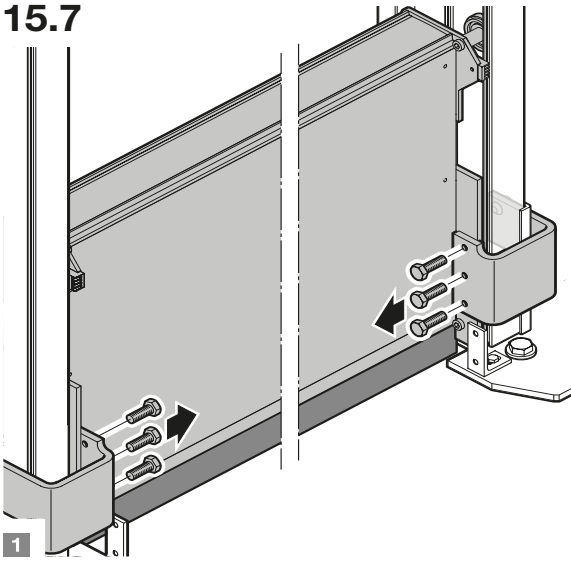

15.8

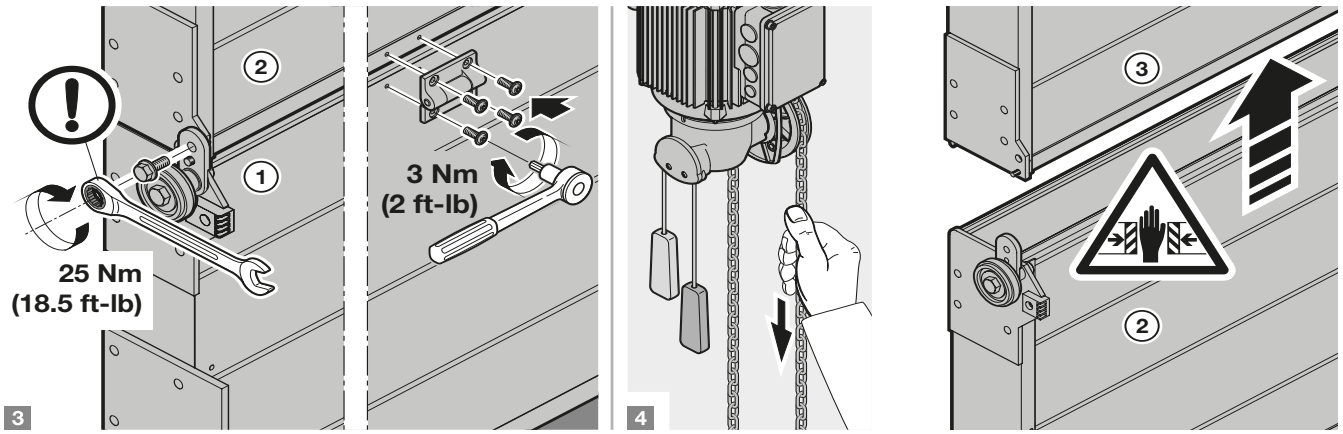
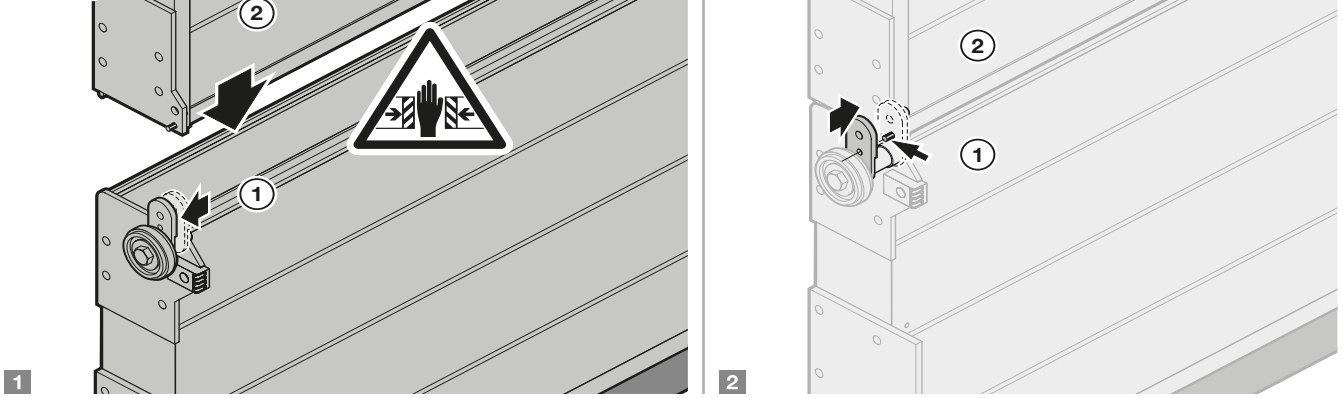

15.9

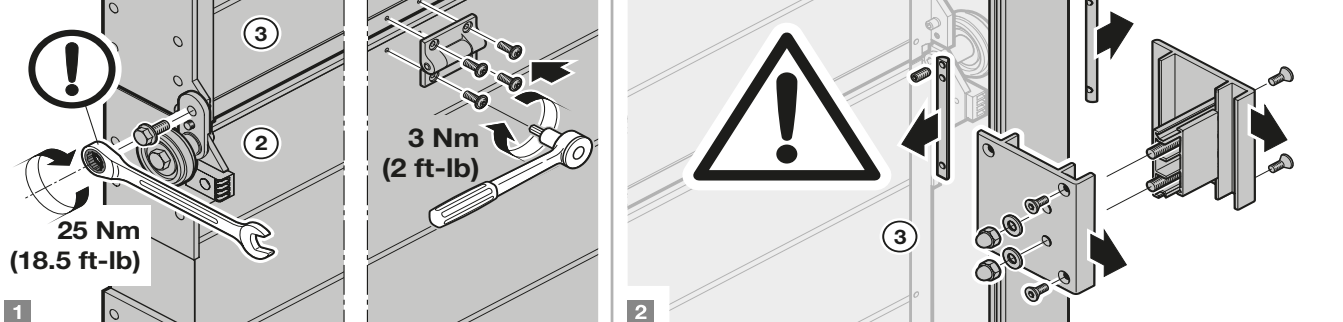

15.10

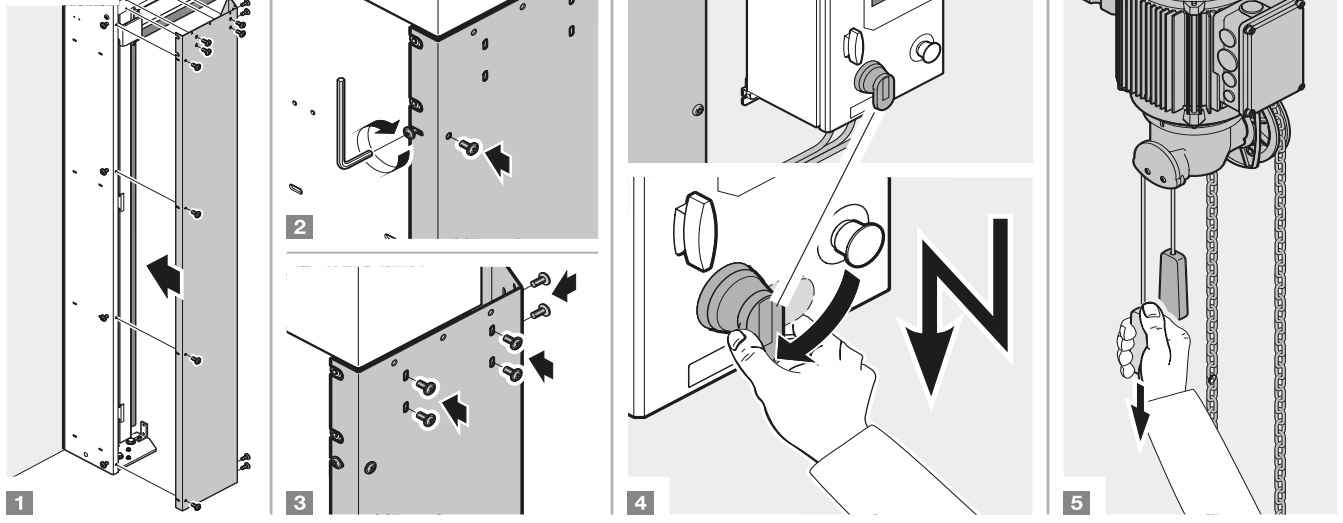

Everything you've always wanted in a high performance door, and more

HÖRMANN

German Engineered, American Made

Our promise to you.

As one of the world's leading manufacturers of doors, we're committed to providing the best quality, value, and selection. Whether industrial or commercial, retail automotive, parking garages, transit,

waste management, fire stations or food processing, we have the door you're looking for. The Hörmann product line has a door for any application, from one manufacturer.



Hörmann High Performance Doors, Burgettstown, PA High Performance Doors



TNR Doors, Barrie, Ontario, Canada High Performance Doors

For assistance, call 1.800.365.3667

CONNECT WITH US



Environmental commitment has been part of our corporate culture for decades. From our manufacturing processes to the products we make.

In everything we do we strive to minimize energy and use of resources through efficient processes, long-lasting quality and innovative engineering.

