

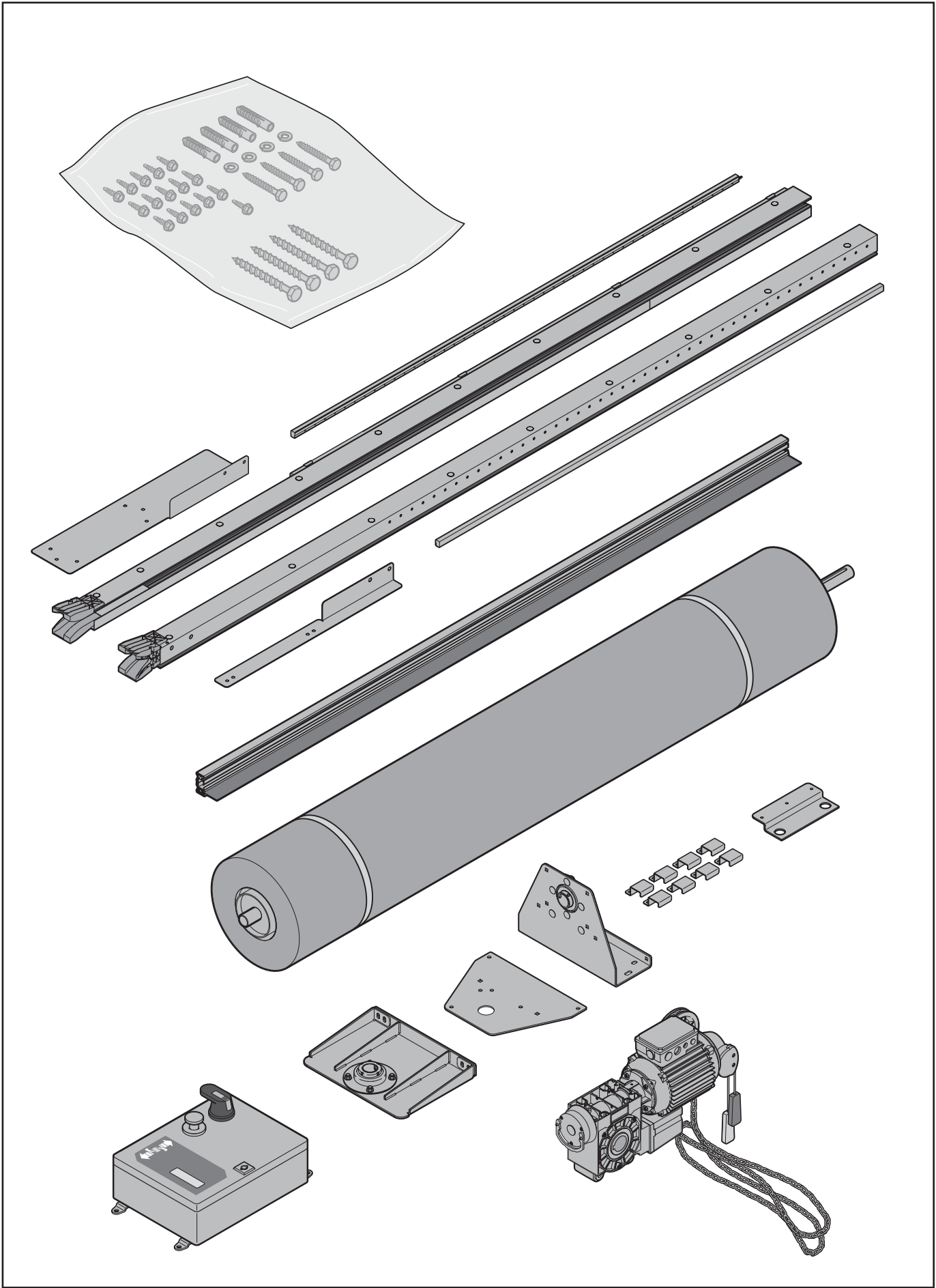

EN

Instructions For Installation, Operating and Maintenance

Steel Ranger 9000 L-LHR



Contents

- 1 About These Instructions..... 4**
- 1.1 Further applicable documents..... 4
- 1.2 Warnings used..... 4
- 1.3 Symbols Used 4
- 1.4 Abbreviations Used 5
- 2  Safety Instructions..... 5**
- 2.1 Intended use..... 5
- 2.2 Organizational Measures 5
- 2.3 Qualification of personnel..... 5
- 2.4 Standards and regulations 5
- 2.5 General safety instructions..... 6
- 2.6 Safety instructions for operation 6
- 2.7 Safety instructions for maintenance and troubleshooting..... 6
- 3 Fitting..... 6**
- 4 Putting into Service 7**
- 4.1 Setting the End-of-travel Positions 7
- 4.2 Test run 7
- 5 Operation..... 7**
- 5.1 Instructed personnel..... 8
- 5.2 Normal wear 8
- 5.3 Emergency-OFF 8
- 6 Inspection and Maintenance 8**
- 6.1 Maintenance intervals..... 8
- 7 Control..... 8**
- 8 Malfunctions and Troubleshooting 9**
- 9 Cleaning and Care 9**
- 10 Extension and Conversion..... 9**
- 11 Dismantling and Disposal..... 9**
- 12 Confirm door opening size and operator mount side from crate labels..... 9**
- 13 Required Fastener for Side Guides..... 10**
- 14 Required Fasteners for Brackets 10**
- 15 Spare Parts..... 25**



..... 11

Dissemination as well as duplication of this document and the use and communication of its content are prohibited unless explicitly permitted. Noncompliance will result in damage compensation obligations. All rights reserved in the event of patent, utility model or design model registration.

Dear Customer,
We are delighted that you have decided to choose a high-quality product from our company.

1 About These Instructions

These instructions are divided into a text section and an illustrated section. The illustrated section can be found after the text section.

These instructions are **original instructions** as outlined in the EC Directive 2006/42/EC. Read through all of the instructions carefully: they contain important information about the product. Pay attention to and follow the instructions provided, particularly the safety instructions and warnings.

Please keep these instructions in a safe place and make sure that they are available to all users at all times.

The manufacturer is not liable for any damage caused as a result of non-compliance with the operating instructions and the information contained therein or due to non-customary use of the industrial door.





Competent operation and proper maintenance influence the performance and availability of your industrial door to a considerable degree. Operating errors and inadequate maintenance lead to avoidable failures. Only competent operation and proper maintenance will guarantee satisfactory, long-term operational safety.

Our customer service department will be happy to assist you. Please contact them if you have any questions after working through these operating instructions.









1.1 Further applicable documents

Depending on the ordered accessories, the delivery includes further instructions, e.g. instructions on how to control the door. Also read these instructions carefully and thoroughly. Pay attention to and follow the instructions provided herein, particularly the safety instructions and warnings.

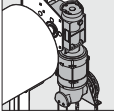
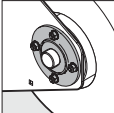
1.2 Warnings used

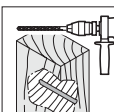
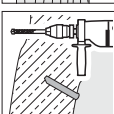
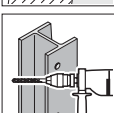
| | |
|--|--|
|  | The general warning symbol indicates a danger that can lead to injury or death . In the text section, the general warning symbol will be used in connection with the caution levels described below. In the illustrated section, an additional instruction refers back to the explanation in the text. |
|  DANGER | |
| | Indicates a danger that leads directly to death or serious injuries. |
|  WARNING | |
| | Indicates a danger that can lead to death or serious injuries. |
|  CAUTION | |
| | Indicates a danger that can lead to minor or moderate injuries. |
| ATTENTION | |
| | Indicates a danger that can lead to damage or destruction of the product . |

1.3 Symbols Used

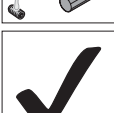
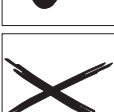
| | |
|---|---|
|  | Important advice to prevent injury to persons or damage to property |
|  | Warning of dangerous electrical voltage |
|  | Operator side |
|  | Bearing side |
|  | Secure |
|  | Drilling in wood |
|  | Drilling in concrete/brick |
|  | Drilling in steel |
|  | Remove residue |
|  | Danger of crushing |
|  | Grease |
|  | Thread lock |
|  | Correct arrangement or activity |
|  | Non-permissible arrangement or activity |



Hand - Tight



Remove and dispose of component or packaging



See text section

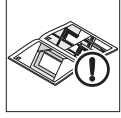

See illustrated section



See separate Fitting Instructions for the control or for the additional electrical control elements

1.4 Abbreviations Used

| | |
|----|-------------------|
| EN | European Standard |
| W | Width |
| LH | Left Hand |
| RH | Right Hand |

2 Safety Instructions

When used properly and for the intended purpose, industrial doors are reliable and safe to operate. Nevertheless, when used incorrectly or for purposes other than those intended, they can pose a risk. We therefore expressly draw your attention to the safety instructions contained in the individual chapters.

2.1 Intended use

Industrial doors are used to close passage openings, to safely shut off rooms, to make machines safe and secure, to save energy costs, to improve the room air conditions and to accelerate the flow of materials.

Intended use also includes paying attention to these instructions and observing inspection and maintenance conditions.

Any other or further use is regarded as non-intended use. The manufacturer/supplier is not liable for any damage resulting from this. The risk is borne solely by the user.

2.2 Organizational Measures

Complying with Laws and Regulations

In addition to the Operating Instructions, generally applicable statutory regulations and other binding regulations for accident prevention and environmental protection must be complied with and corresponding instructions must be given in respect of these. This also applies to national regulations which must be observed locally.

Keeping the Operating Instructions Ready at Hand

Always have the Operating Instructions available at the location where the industrial door is used.

No Conversion Work

Without the supplier's approval, do not carry out any modification, attachment or conversion work on the industrial door which might compromise safety!

No Program Modifications

Do not make any program modifications (software) on programmable control systems!

Fire Extinguishers

The location and operation of fire extinguishers must be indicated by appropriate information signs! Pay attention to the statutory fire-alarm and fire-fighting regulations.

2.3 Qualification of personnel

Only qualified and instructed personnel may fit, operate and maintain the industrial door.

Before commencing work the assigned personnel must read these instructions, particularly chapter 2.

For safety reasons, specify distinct responsibilities for operation, maintenance and repairs to ensure that there are no unclear assignments.

2.4 Standards and regulations

As the operator or owner of the door system, you are responsible for ensuring that the following regulations are observed and complied with (without any claim to completeness).

European Standards

| | |
|------------|---|
| EN 12445 | Doors – Safety in use of power operated doors: Test methods |
| EN 12453 | Doors – Safety in use of power operated doors: Requirements |
| EN 12604 | Doors – Mechanical aspects: Requirements |
| EN 12978 | Doors – Safety devices for power operated doors: Requirements and test methods |
| EN 60335-1 | Safety of electrical equipment for domestic use and similar purposes – part 1: General requirements |
| EN 61508 | Functional safety of electrical / electronic / programmable electronic safety-related systems |

VDE Regulations

| | |
|----------|--|
| VDE 0113 | Electrical installations with electronic equipment |
| VDE 0700 | Safety of electronic devices for domestic use and similar purposes |

Accident prevention regulations

| | |
|----------|--|
| BGV A3 | Electrical installations and equipment |
| ASR A1.7 | Technical Rules for Workplaces |

2.5 General safety instructions

- In addition, also observe the generally applicable statutory regulations and other binding regulations for accident prevention and environmental protection, country-specific regulations, and the recognised specialist technical rules for safe and competent working must be observed. Before beginning work, instruct personnel in accordance with these rules and regulations.
- Always keep these instructions ready to hand at the location where the industrial door is used.
- Without the supplier's prior approval, do not carry out any modification, attachment or conversion work on the industrial door which might compromise safety.
- Do not make any modifications to the software on programmable control systems.
- The location and operation of fire extinguishers must be indicated by appropriate information signs. Observe the statutory fire alarm and fire-fighting regulations.
- All work on the industrial door (such as maintenance, cleaning work and inspections) may only be performed during an operational shutdown.
- Only qualified electricians may perform work on the mains supply.
- Before undertaking any work, disconnect the system from the mains supply and ensure that it cannot be inadvertently turned on. If available, deactivate the emergency opening lever.

2.6 Safety instructions for operation

- Before actuating the door, make sure that no persons or objects are located in the door's area of travel.
- Do not reach into the guide or guide area while the door is in operation.
- Only actuate the industrial door if it is safe and functional. All protective devices and safety-related devices (e.g. detachable protective devices and emergency-OFF devices) must be present and functioning.
- Do not modify or put the safety devices out of operation.

2.7 Safety instructions for maintenance and troubleshooting

- Perform inspection and maintenance work as described in chapter 6. Comply with the maintenance intervals and note the information on the replacement of parts / partial equipment.
- Maintenance and troubleshooting may only be carried out by specialist personnel.
- Only use spare parts that comply with the technical requirements specified by the manufacturer. This is always guaranteed when original spare parts are used.
- Only carry out welding, burning and grinding work on the industrial door if this work has been expressly approved. For example, there may be a risk of fire and explosion! Prior to welding, burning and grinding, remove dust and combustible materials from the industrial door and its surroundings and ensure that there is adequate ventilation (risk of explosion)!
- Before disassembling the operator, fix the shaft on the operator side (e.g. with a forklift).

3 Fitting

DANGER

Mains voltage!

Contact with the mains voltage presents the danger of a deadly electric shock. For that reason, observe the following warnings under all circumstances:

- ▶ Only qualified electricians may perform work on the mains supply.
- ▶ Make sure that the on-site electrical installation complies with the applicable safety requirements.
- ▶ Ensure that the national regulations governing the operation of electrical equipment are complied with.
- ▶ Install the control unit for the industrial door operator within sight of the door.
- ▶ Before undertaking any electrical work, disconnect the system from the mains supply and ensure that it cannot be inadvertently turned on.

ATTENTION

External voltage

External voltage on the connecting terminals of the control will destroy the electronics.

- ▶ Do not apply any external voltage (e.g. mains voltage) to the connecting terminals of the control unit.

ATTENTION

Pull forces on electric cables

Pull forces on electric cables will destroy the electronics.

- ▶ Never pull on the connecting leads of the electrical components.

NOTE:





Also follow the other enclosed instructions for installation of electrical connections and fitting additional electrical control elements.

To fit the door:

1. Take precautionary measures to make the site safe.
2. Check the on-site fitting conditions for the door (check measurements).
3. Check the quality of the structure for its strength.
4. Choose suitable fastenings.
5. Unpack the door and check for damage.
6. If delivered by a freight forwarder: Report any damage immediately.
7. Check that the delivery is complete.
The delivery must include:
 - 2 side elements
 - Barrel with curtain
 - 1 box containing hardware and operator
 - Operator and shaft cladding (option)
8. Dispose of the packaging material.
9. Fit the door as shown in the illustrated section.

4 Putting into Service

|  WARNING | |
|--|--|
| Faulty door | |
| A faulty door may injure persons or damage objects. | |
| ▶ Only put the door into service if it is in perfect condition. | |

|  WARNING | |
|---|---|
|    | Door movements Door travel may injure persons or damage objects. <ul style="list-style-type: none"> ▶ Make sure that no persons or objects are in the door's closing area during operation. ▶ Never use the door to lift objects or persons. ▶ Never reach into the guide, guide are, chain, toothed wheel or return pulley during door operation. |

4.1 Setting the End-of-travel Positions

The end-of-travel positions of the door are set on the control cabinet.

NOTE:

Please follow the instructions supplied with the operator and control unit.

4.1.1 CLOSE end-of-travel position

| ATTENTION |
|---|
| Exceeding the CLOSE end-of-travel position If the door travels beyond the <i>Close</i> end-of-travel position, the bottom profile may be compressed. This could disrupt the diode deactivation of the light grille. |
| ▶ Never exceed the <i>CLOSE</i> end-of-travel position. |

- ▶ Set the *CLOSE* end-of-travel position so that the bottom profile makes full contact with the floor. If the guide is supported or the floor uneven, select the bottom edge of the side element as the end-of-travel position.

4.1.2 OPEN end-of-travel position





| ATTENTION |
|---|
| Exceeding the OPEN end-of-travel position If the door travels beyond the <i>OPEN</i> end-of-travel position, there is a risk of the door curtain slipping out of the side guides and sustaining damage. |
| ▶ Never exceed the <i>OPEN</i> end-of-travel position. |

- ▶ Set the *OPEN* end-of-travel position so that the lower edge of the bottom profile corresponds to the dimension for the door height.

4.2 Test run

1. After fitting the door, test the functional safety according to the acceptance / handing-over report.
2. Verify in the test log book (dated and signed) that a test run has been successfully completed.
3. Hand the entire door documentation over to the owner or operator of the door.

5 Operation

|  WARNING | |
|--|---|
|    | Door movements Door travel may injure persons or damage objects. <ul style="list-style-type: none"> ▶ Make sure that no persons or objects are in the door's closing area during operation. ▶ Make sure that the door has opened completely before driving in or out! Never drive or walk through doorways unless the door has reached the <i>OPEN</i> end-of-travel position. ▶ Whenever driving in or out of the opening, always check that the door curtain has travelled up far enough to provide the necessary passage height. ▶ Never use the door to lift objects or persons. ▶ Do not reach into the guide or guide area while the door is in operation. |

| ATTENTION |
|---|
| Emergency operation devices Too frequent use of the emergency operation devices may damage them. This will also void the warranty for the door. |
| ▶ Only use the emergency operation devices in the case of a power failure or during repair work. |

| ATTENTION |
|---|
| Aggressive media, wind and heat Aggressive media, wind and heat may damage the door. |
| ▶ Protect the door from aggressive media: <ul style="list-style-type: none"> – Saltpeter from stone or concrete – Cement – Plaster – Acids – Alkali – Road salt – Aggressive paints or sealants – Aggressive sealants |
| ▶ Avoid temperatures greater than 50°C near the door. |

5.1 Instructed personnel

The door may only be operated by persons who have been instructed in its proper use. A person is considered to be instructed (EN 12453), if he/she has received instruction as to how to operate the door safely and has received permission from the owner to use the door system.

5.2 Normal wear

The design of the door represents state-of-the-art technology. Pressure marks and abrasive wear are design-related and cannot be avoided.





5.3 Emergency-OFF



- ▶ In emergency situations, de-energise the control by actuating the main switch, pulling the mains plug or, if available, actuating the red **emergency-OFF** button.

6 Inspection and Maintenance

|  WARNING | |
|---|--|
| Unmaintained doors | |
| There is a danger of injury and damage if the door is not regularly maintained. This will also void the warranty. | |
| ▶ Inspect and maintain the door regularly as described in these instructions or entrust this work to the manufacturer's service department. | |

|  DANGER | |
|---|--|
| Mains voltage! | |
| Contact with the mains voltage presents the danger of a deadly electric shock. | |
| ▶ Before undertaking any electrical work, disconnect the system from the mains supply and ensure that it cannot be inadvertently turned on. | |

|  WARNING | |
|--|--|
|    | Door movements There is a danger of injury and damage if the door is actuated during inspection or maintenance work. |
| | ▶ Before undertaking any work, disconnect the system from the mains supply and ensure that it cannot be inadvertently turned on. |
| | ▶ If available, deactivate the emergency opening lever / handle. |

|  WARNING | |
|--|---|
|  | Falling parts During dismantling, parts may fall and injure persons or damage property. |
| | Cladding (option) ▶ Fix the cladding (e.g. with a forklift) before dismantling. |
| | Shaft ▶ Fix the shaft (e.g. with a forklift) before dismantling the operator. |

Only inspect and maintain the door yourself if you are a qualified specialist (competent person according to EN 12635). In other words, you have the suitable training, specialist knowledge and practical experience to allow you to carry out inspection and maintenance correctly and safely. Observe all the applicable regulations governing work safety.

In general, we recommend entrusting maintenance / inspection to the manufacturer's service department.

The high-speed door is low-maintenance. In normal operating conditions, all the bearings, including the gears, are lubricated for life and are maintenance-free.

6.1 Maintenance intervals

In compliance with the guidelines for power-operated windows, doors and gates (ASR A1.7) testing and maintenance of the door must be carried out once a year, and as far as possible at the same intervals.

Depending on the size of the door and the annual number of door cycles, we recommend the following maintenance intervals:

In the case of a high number of door cycles (> 50000 per year):

Servicing of the functional elements every six months:

- Electric operator and brake
- All screw connections
- Travel limit cut-off / creep speed switch-over
- Control / impulse generator

In the case of a smaller number of door cycles:

Annual servicing in conjunction with the stipulated test procedures according to German accident prevention regulations UVV (in compliance with ASR A1.7).

- ▶ Check the function of the "D" devices (photocell / light grille) every six months.

7 Control

The control system is manufactured individually for each door ordered. The respectively applicable wiring diagram is deposited in the control cabinet.

- ▶ Add the wiring diagram and software description to these instructions.

Each control cabinet has its own identification number.

- ▶ Always quote this number in the case of queries.

8 Malfunctions and Troubleshooting

In the case of malfunctions, contact the Customer Service.

Operator power

The operating voltage must be 230 V ± 5 % or 480 V ± 5 %. If the voltage deviates greatly from this, there may be problems with the operator power.

9 Cleaning and Care

Use warm water together with a neutral, non-abrasive cleaning agent (household detergent, pH value 7).

To clean the surface, use only a soft cloth or window leather. Rinse off any dirt and dust particles with clear water.



10 Extension and Conversion

|  WARNING |
|---|
| <p>Unsuitable components</p> <p>Unsuitable components could overload the door construction. This could lead to serious injury.</p> <ul style="list-style-type: none"> ▶ Only use components approved by the manufacturer. |

Only extend or convert this door system with the manufacturer's permission.

Carrying out any structural alterations to the product without the manufacturer's permission renders the warranty and product liability null and void.

11 Dismantling and Disposal

|  WARNING | |
|--|---|
|  | <p>Falling parts</p> <p>During dismantling, parts may fall and injure persons or damage property</p> <p>Cladding (option)</p> <ul style="list-style-type: none"> ▶ Fix the cladding (e.g. with a forklift) before dismantling. <p>Shaft</p> <ul style="list-style-type: none"> ▶ Fix the shaft (e.g. with a forklift) before dismantling the operator. |

Only dismantle this door if you are qualified to do so (i.e. are a competent person in accordance with EN 12635). In other words, you have the suitable training, specialist knowledge and practical experience to allow you to dismantle the door correctly and safely.

Observe all the applicable regulations governing work safety when dismantling the door.

To dismantle and dispose of the door:

1. Open the door fully.
2. Carefully roll up the door manually (emergency manual operation).

3. Tape round the door curtain several times with strong adhesive tape (e.g. packing tape) to prevent it from unrolling.
4. Drive a forklift truck with suitable pallet or supporting frame underneath the shaft, so that the shaft rests on the pallet or supporting frame.
5. Release the fastenings securing the bearing and the operator.
6. Lift the shaft or top part together with the operator off the support brackets.

CAUTION

The operator may slide off the barrel journal

- ▶ When letting the shaft or top part down, take care to keep it level.
7. Dismantle the side guides or side elements and support brackets.
 8. Disassemble the door into component parts and dispose of them properly.

| ATTENTION |
|---|
| Do not unwrap curtain until mounted on structure |

12 Confirm door opening size and operator mount side from crate labels

Assure that required tools are available for installation:

| Required tools | |
|----------------|--------------------------------------|
| Allen Wrench | 10 mm |
| Wrench | 19 mm / 17 mm / 15 mm / 13 mm / 7 mm |
| Bubble Level | 48 inch |
| Water Level | |

| Tape Measure | |
|------------------|--|
| Drill – Concrete | Ø 10 mm × 70 mm |
| Drill – Steel | Ø 8.5 mm × 40 mm Ø 7.0 mm × 30 mm Ø 6.4 mm × 40 mm |
| Drill – Wood | Ø 5.5 mm × 40 mm |

- Fork Lift
- Knife
- Plastic Bar Clamp

13 Required Fastener for Side Guides

| Material | Description | Drilling Parameters | Required Tools | Tightening Torqu |
|--|---|--------------------------|---|------------------|
| Wood | Ø 6 × 60, Torx Pan Head Sheet Metal Screw | No Drilling Required | Torx Screw Driver T30 * | Hand-Tight |
| Brick | Ø 6 × 60, Torx Pan Head Sheet Metal Screw Wall Anchor, Würth W-ZX 8 | Ø 8 mm Depth: 70 mm | Drill Ø 8 mm Torx Screw Driver T30 * | |
| Concrete | Ø 6 × 60, Torx Pan Head Sheet Metal Screw Wall Anchor, Würth W-ZX 8 | Ø 8 mm Depth: 70 mm | Drill Ø 8 mm Torx Screw Driver T30 * | |
| Sheet Metal (t ≤ 3 mm) | Ø 6.3 × 19, Torx Pan Head Sheet Metal Screw | Ø 5 mm Depth: 25 mm | Drill Ø 5 mm Torx Screw Driver T30 * | 7-9 ft·lb |
| Steel (t > 3 mm) | Ø 6.3 × 19, Torx Pan Head Sheet Metal Screw | Ø 5.7 mm Depth: 30 mm | Drill Ø 5.7 mm Torx Screw Driver T30 * | |
| * Depending on the clamps used a drill and tool length of approx. hole depth + 80 mm is required | | | | |

14 Required Fasteners for Brackets

| Material | Description | Drilling Parameters | Required Tools | Tightening Torqu |
|------------------------|--|--------------------------|---------------------------------------|------------------|
| Wood | Ø 8 × 60, Hex Washer Head Lag Screw | Ø 5.5 mm Depth: 40 mm | Drill Ø 5.5 mm Wrench 13 mm | Hand-Tight |
| Brick | Ø 8 × 60, Hex Washer Head Lag Screw Wall Anchor, Würth W-ZX 10 | Ø 10 mm Depth: 70 mm | Drill Ø 10 mm Wrench 13 mm | |
| Concrete | Ø 8 × 60, Hex Washer Head Lag Screw Wall Anchor, Würth W-ZX 10 | Ø 10mm Depth: 70 mm | Drill Ø 10 mm Wrench 13 mm | |
| Sheet Metal (t ≤ 3 mm) | Ø 8 × 22, Serrated Indented Hex Washer Sheet Metal Screw | Ø 7 mm Depth: 30 mm | Drill Ø 7 mm Wrench 13 mm | 18.5 ft lb |
| Steel (t > 3 mm) | Ø M8 × 30, Serrated Indented Hex Washer Machine Screw M8 × 24 Fender Washer, M8 Hex Nut | Ø 8.5 mm Depth: 40 mm | Drill Ø 8.5 mm Wrench 13 mm | |
| Steel (t ≥ 12 mm) | Ø M8 × 30, Serrated Indented Hex Washer Machine Screw | Ø 6.4 mm Depth: 40 mm | Drill Ø 8.5 mm Tap M8 Wrench 13 mm | |

1



$W \pm 3/16''$

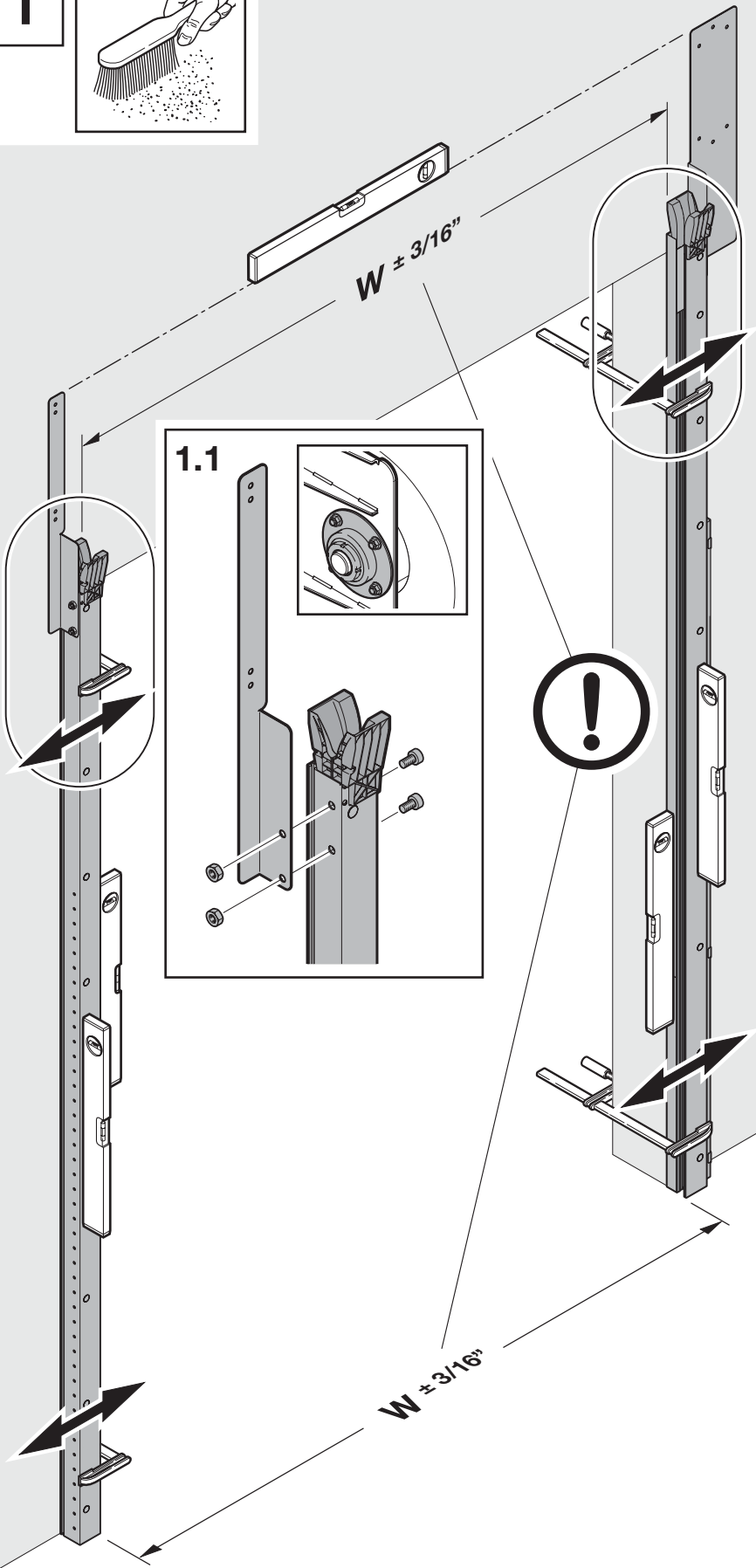

1.1

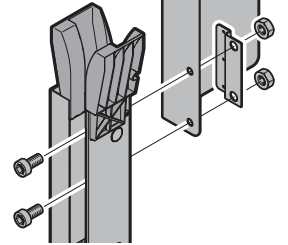
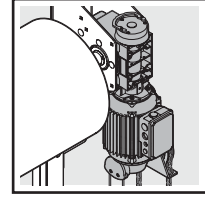

1.1

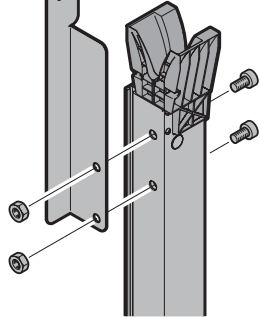
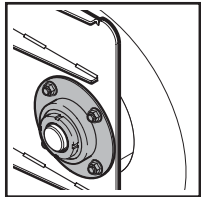

1.2

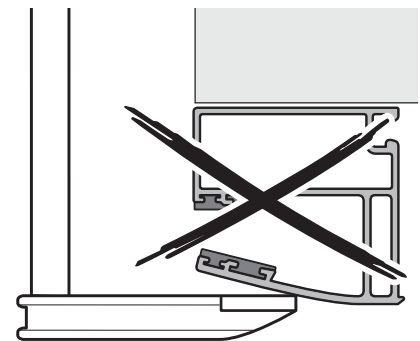
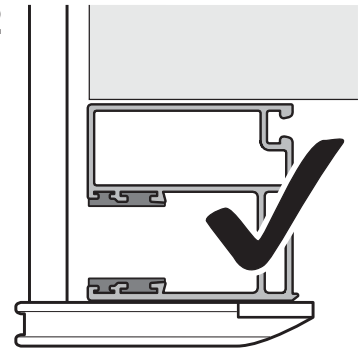

2



2.2

2.2

2.1

2.1

$W \pm 3/16''$

$W \pm 3/16''$

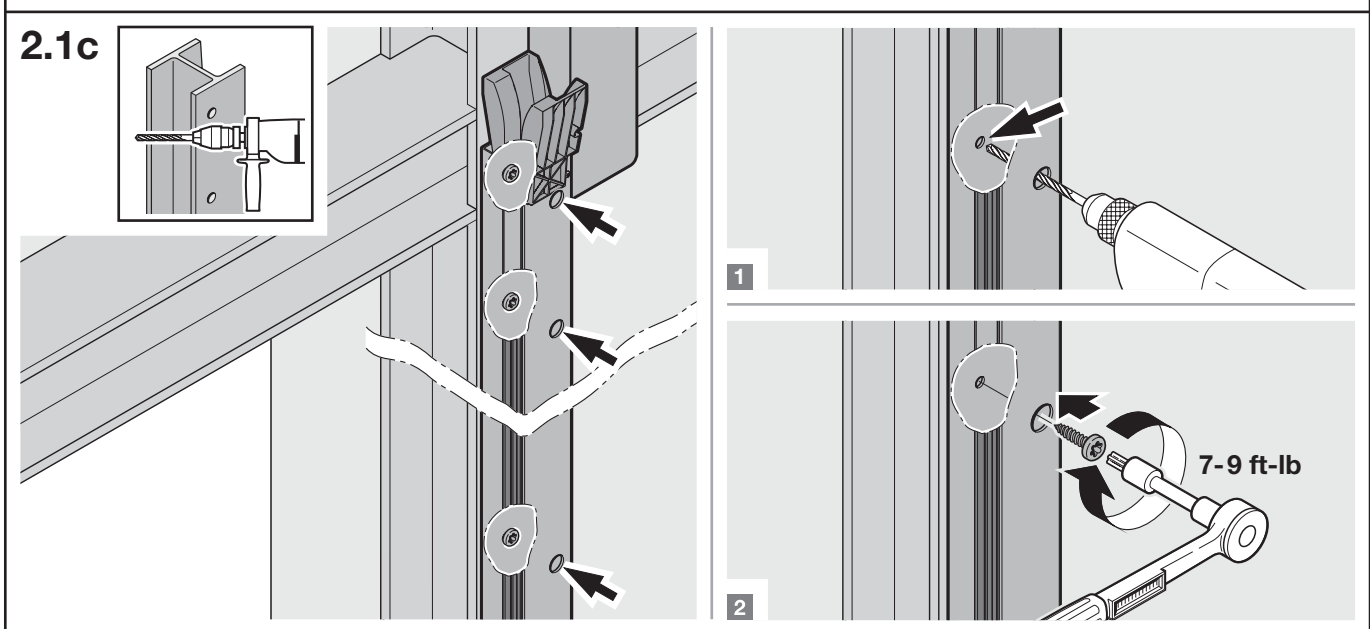
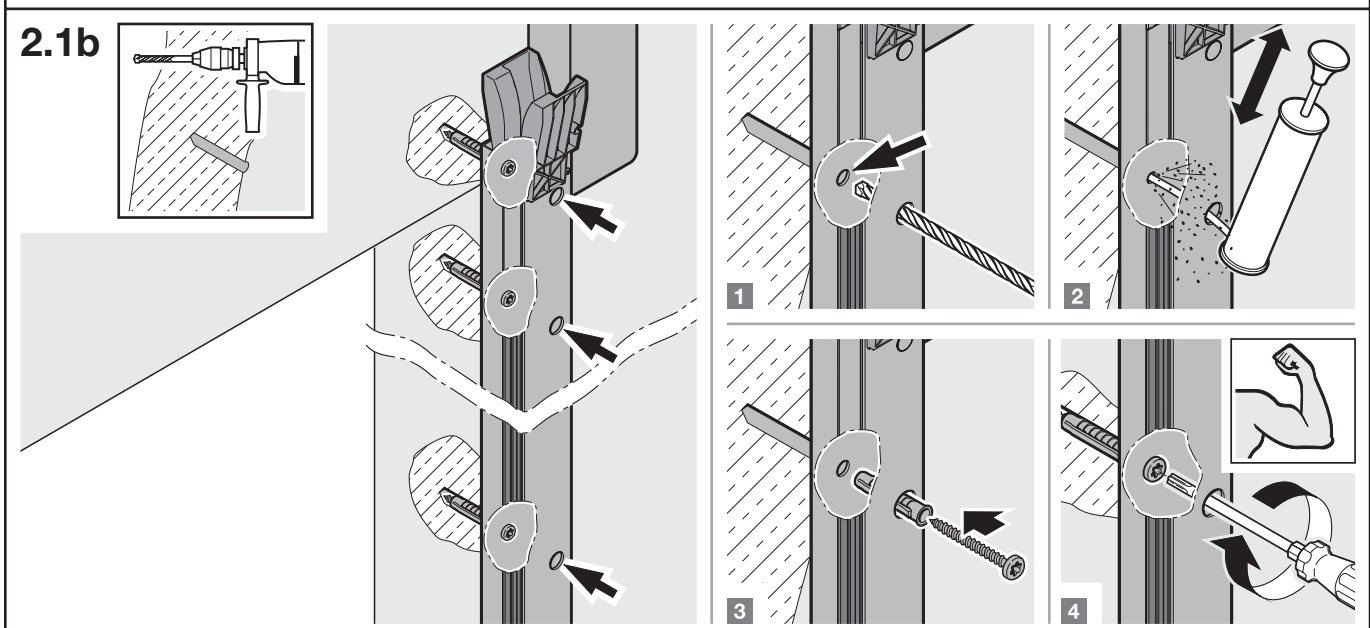
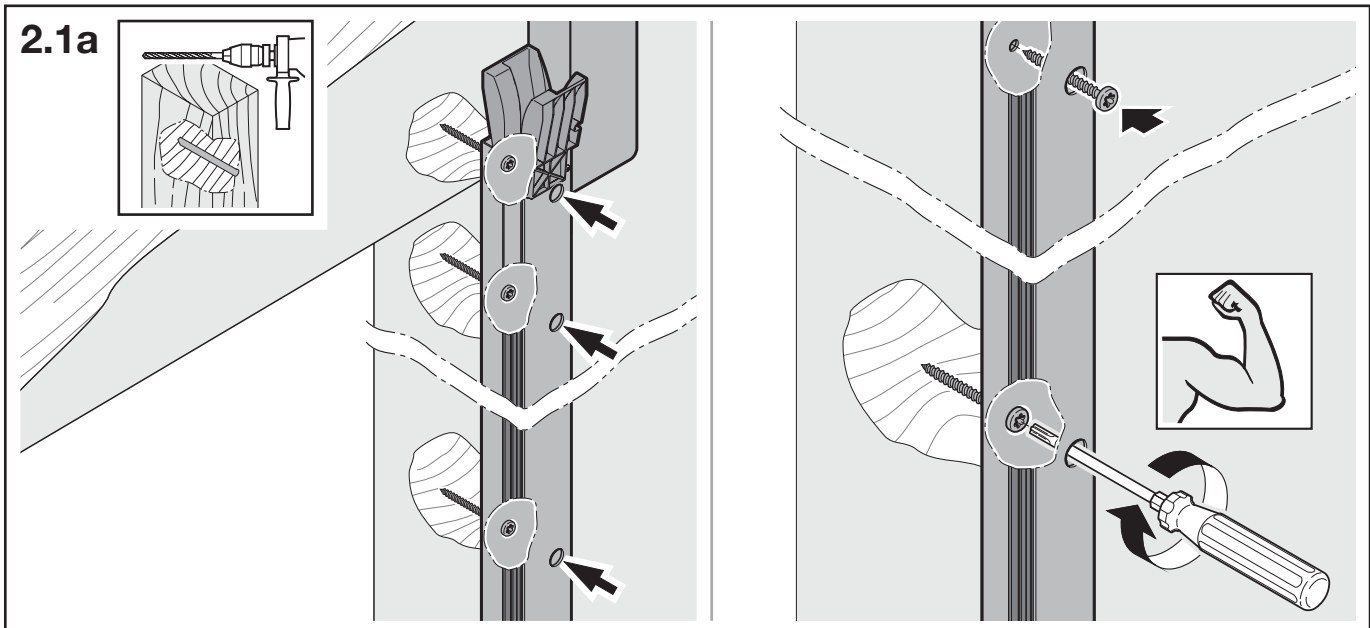

2.2a

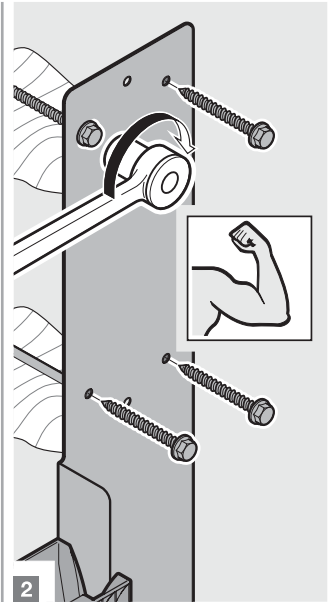
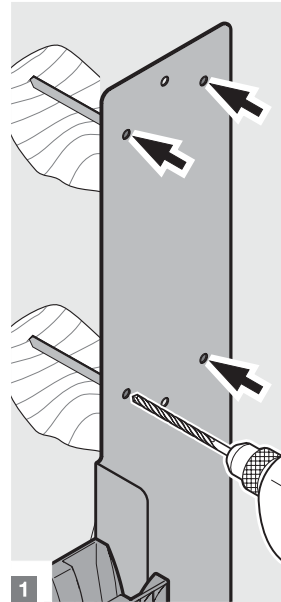
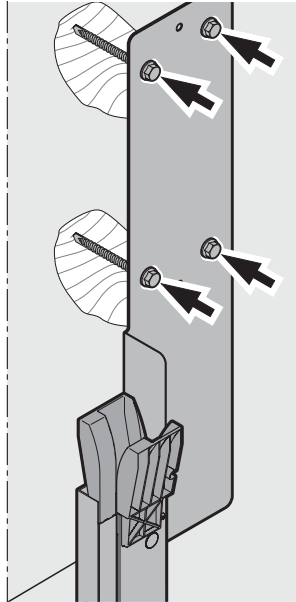
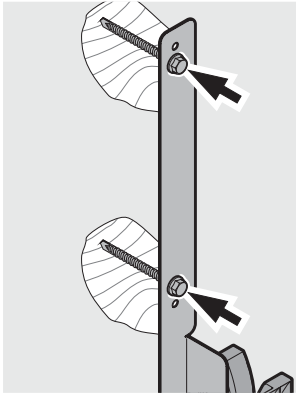
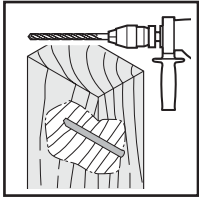

2.2b

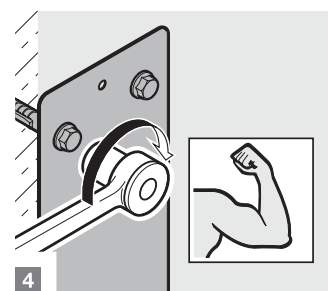
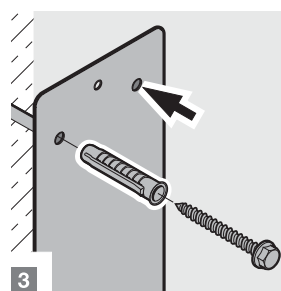
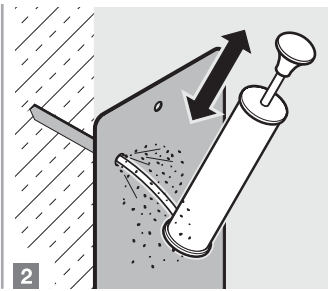
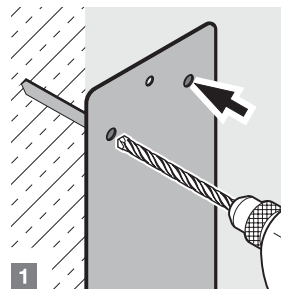
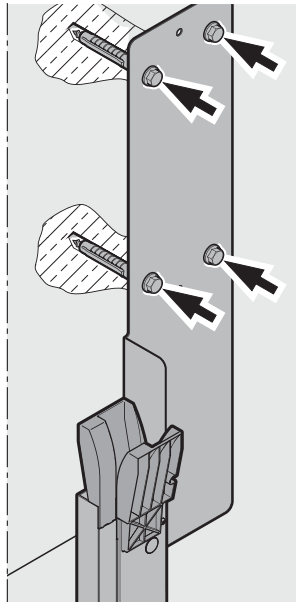
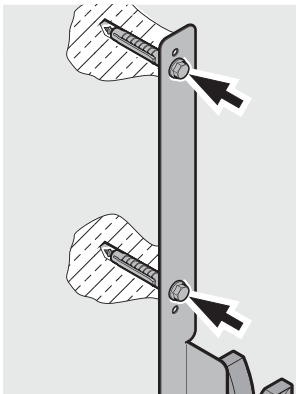
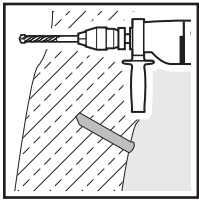

2.2c

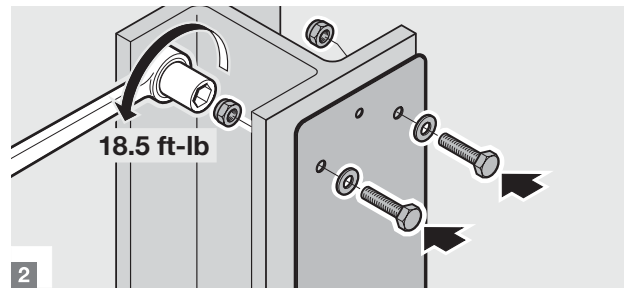
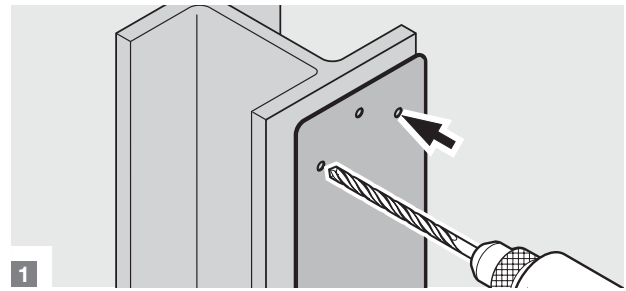
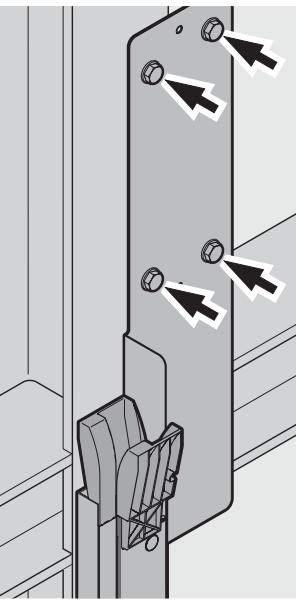
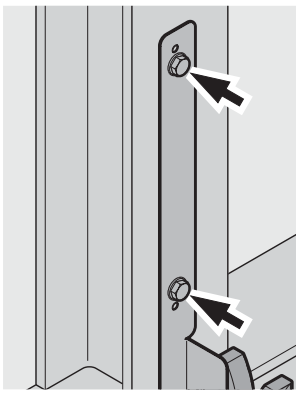
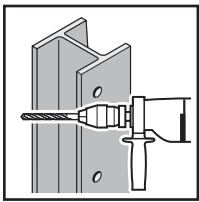

3

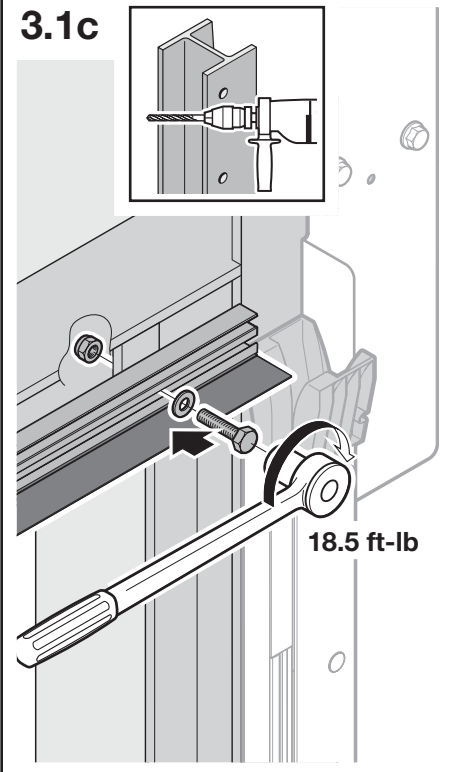
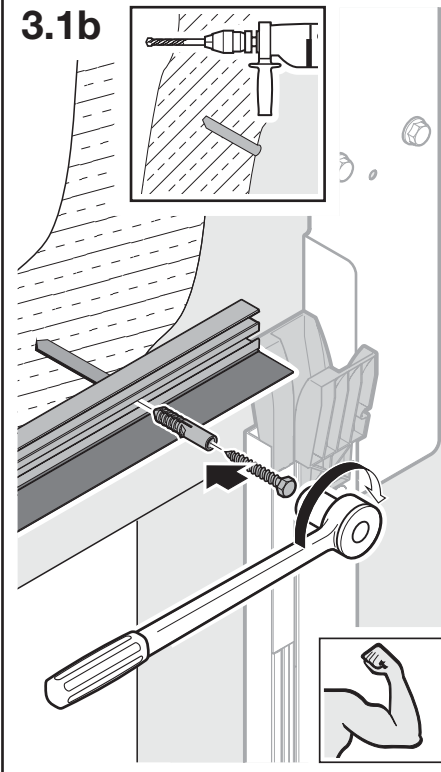
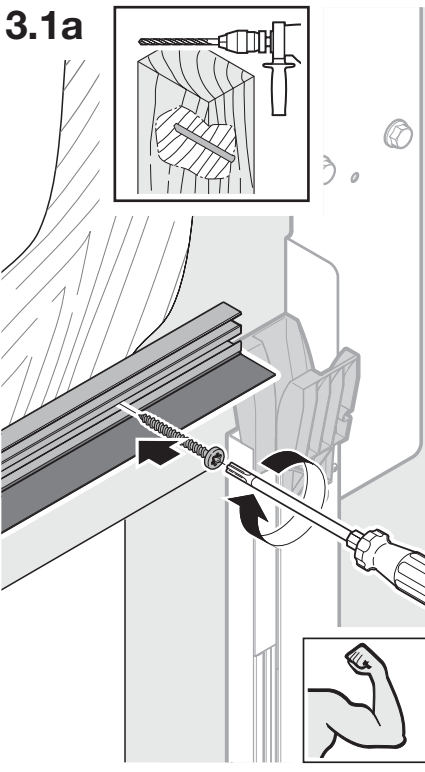
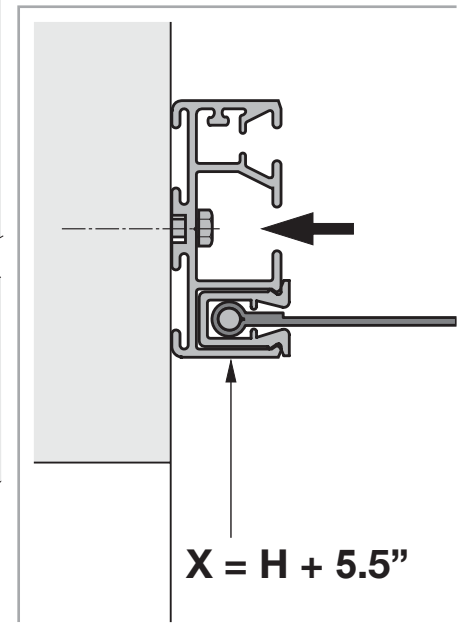
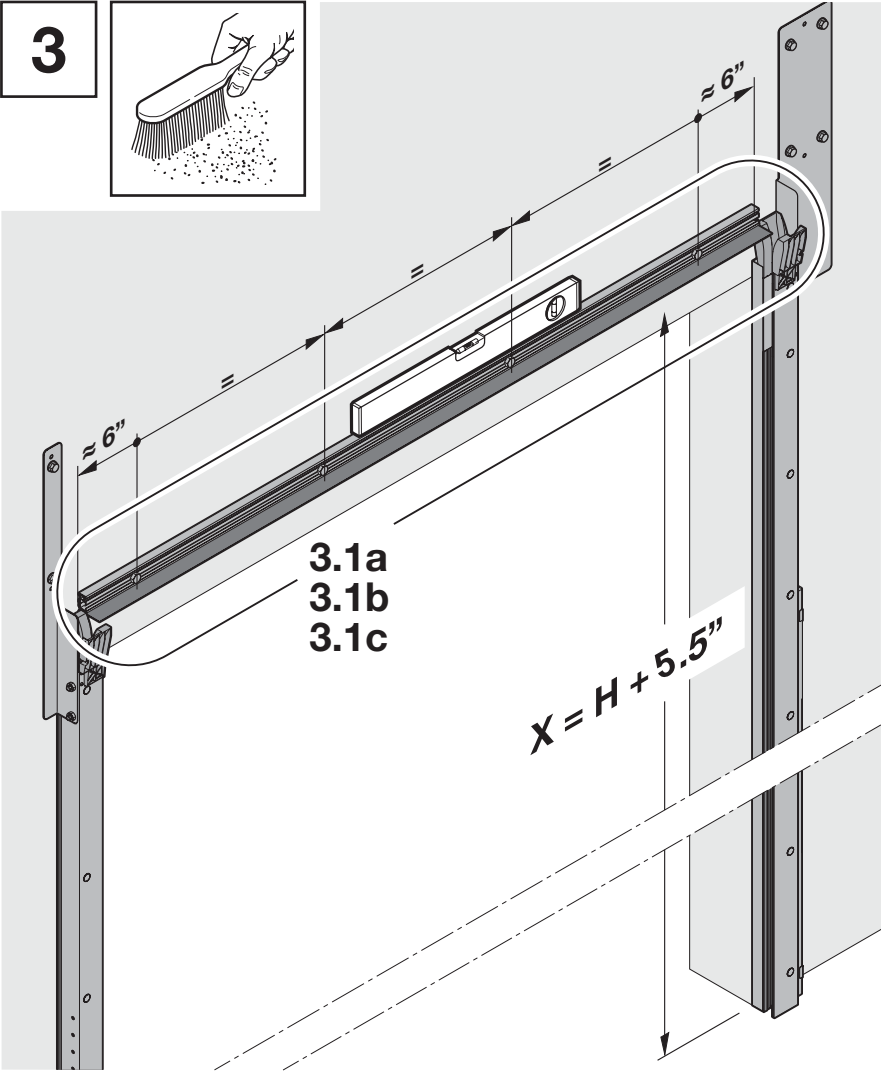

4

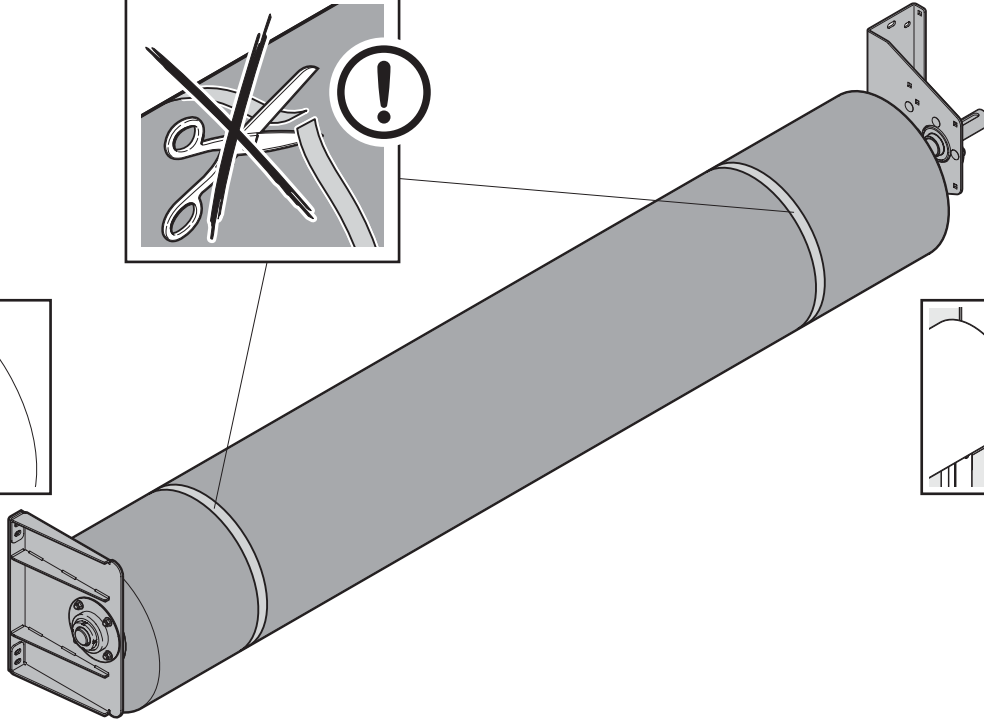
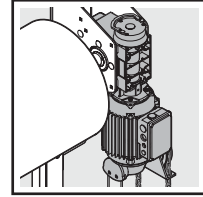
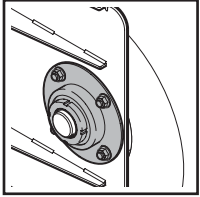
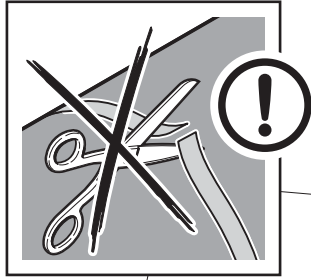

4.1

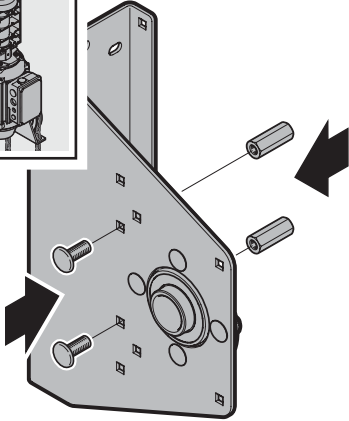
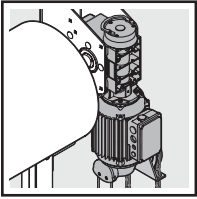

4.2

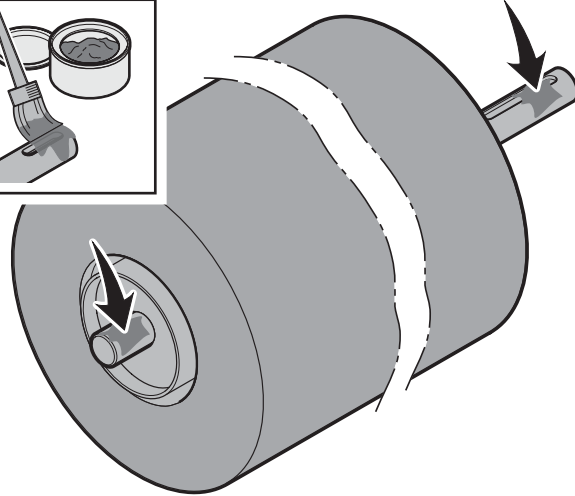
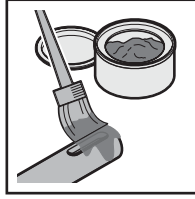

4.3

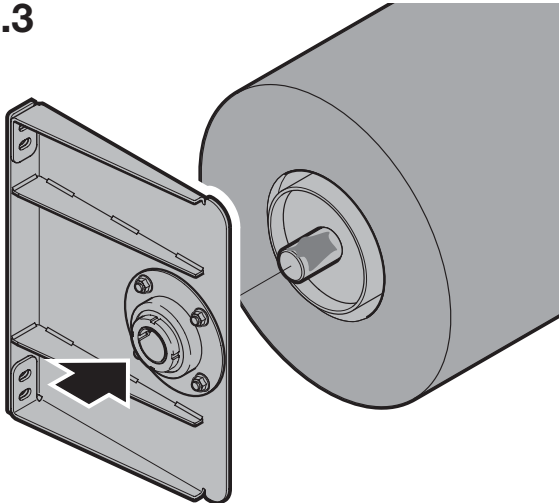

4.4

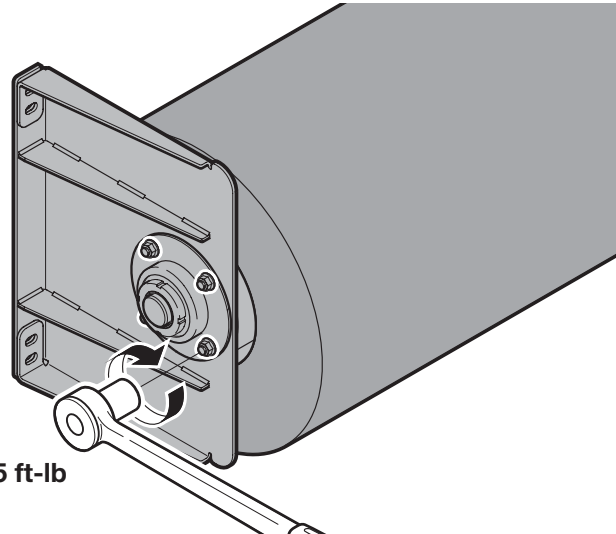

45 ft-lb

5

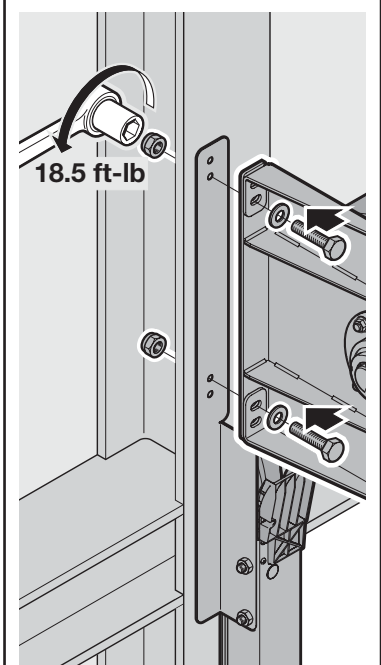
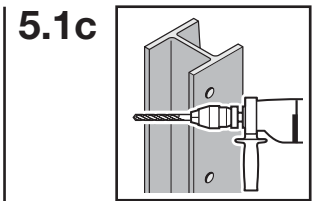
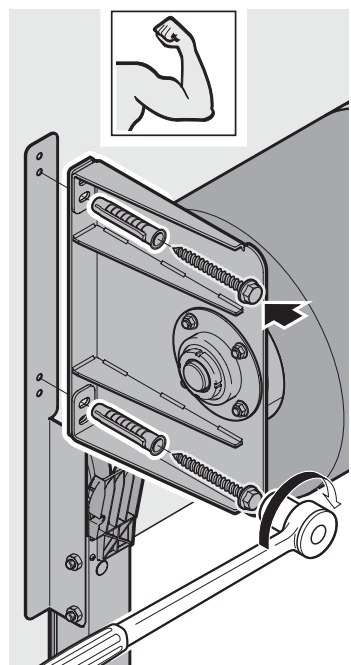
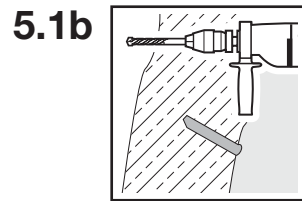
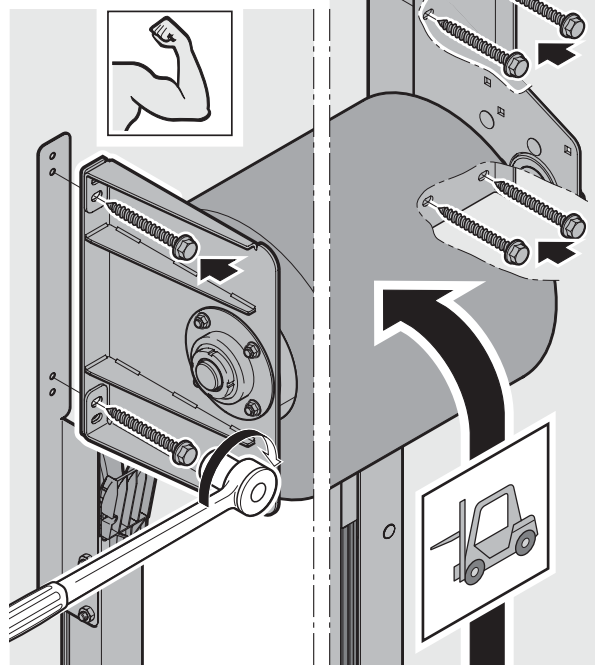
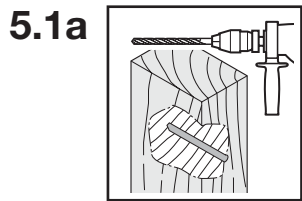
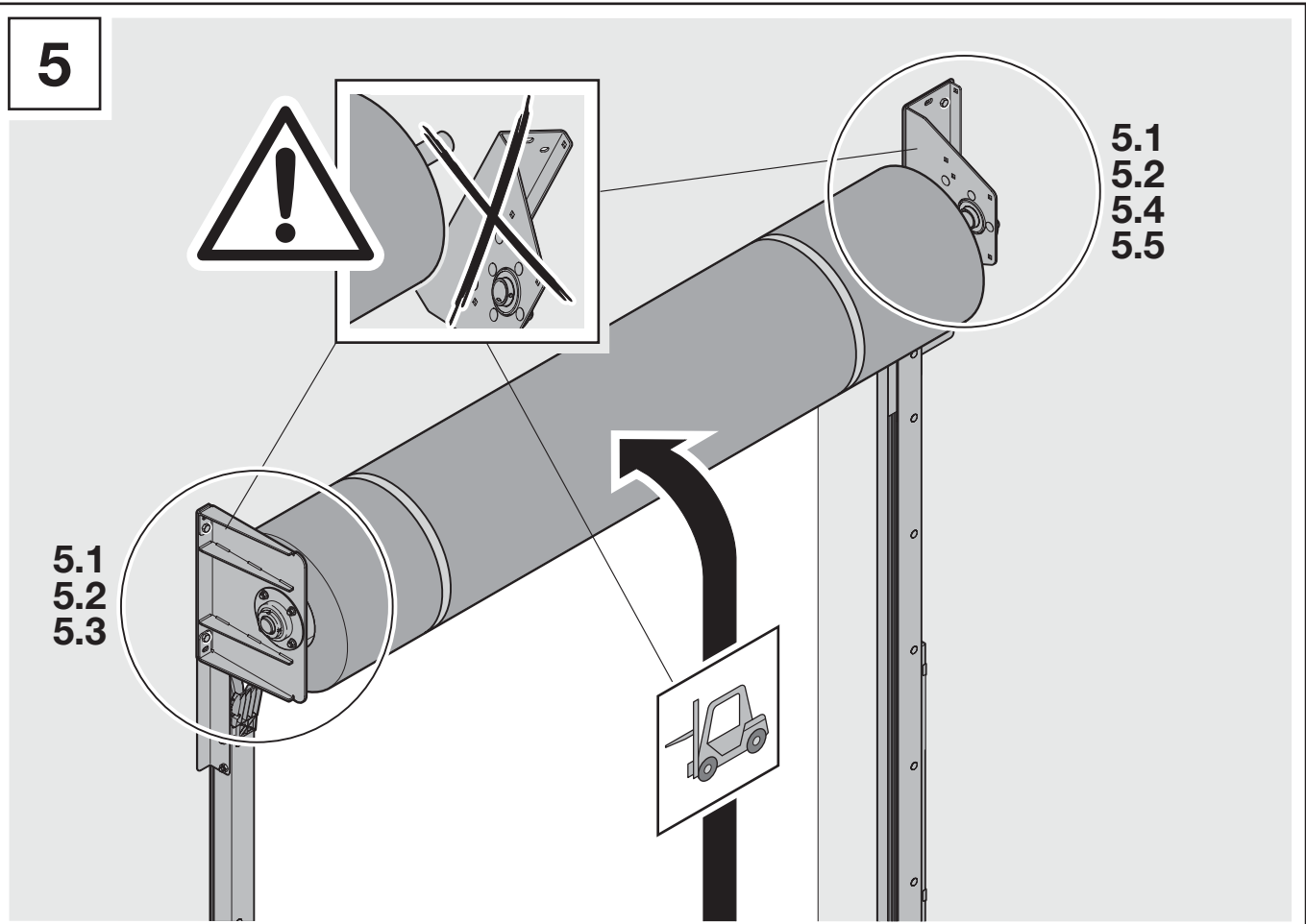

5.2

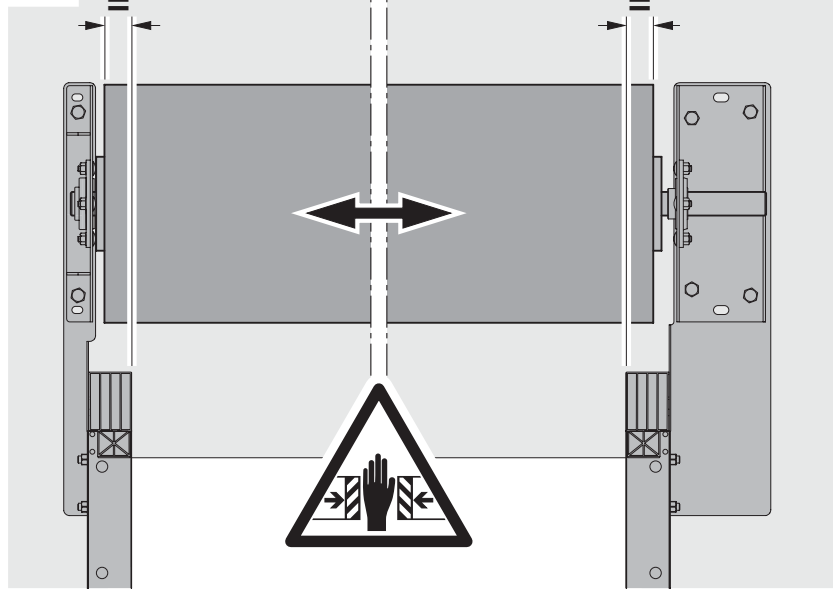

5.3

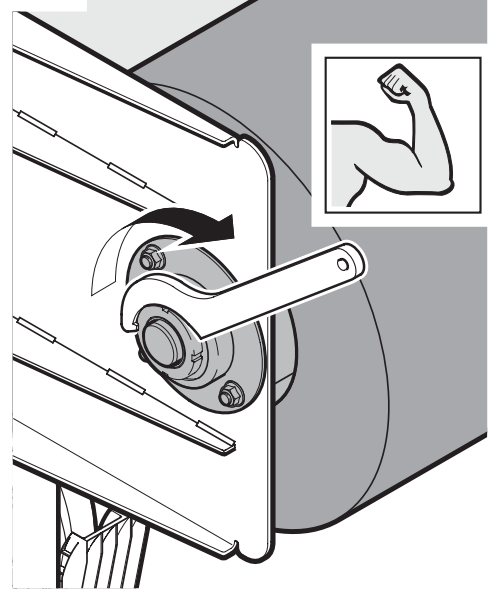

5.4

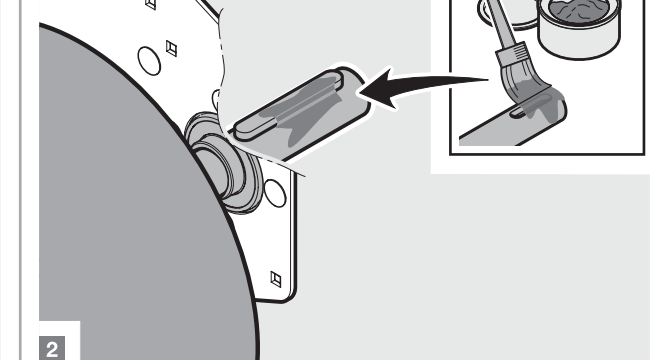
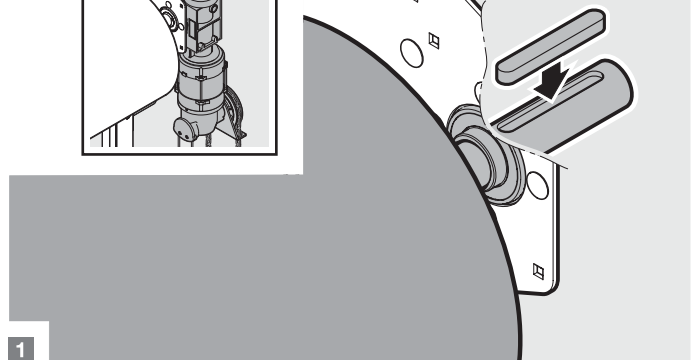

5.5

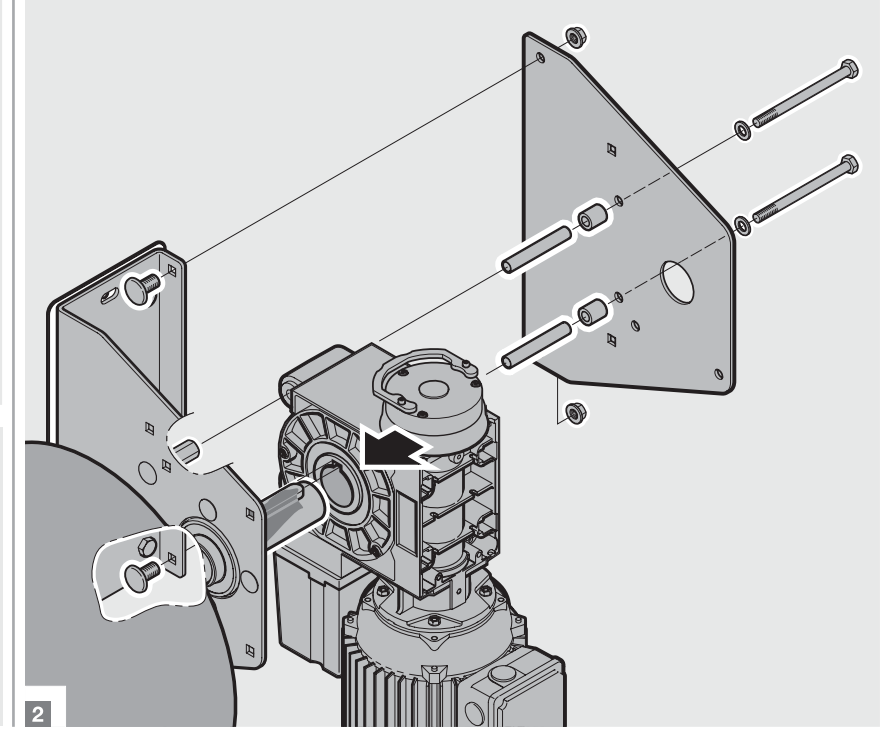
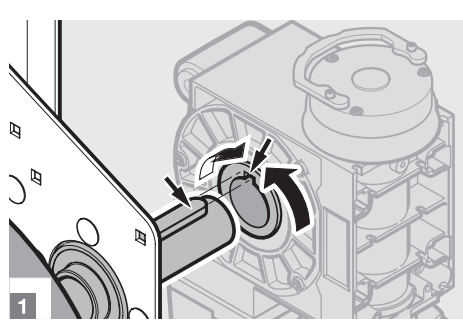
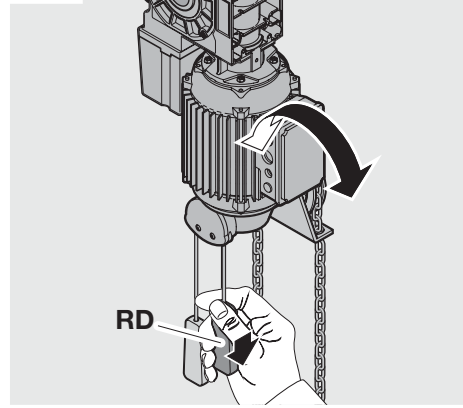

6

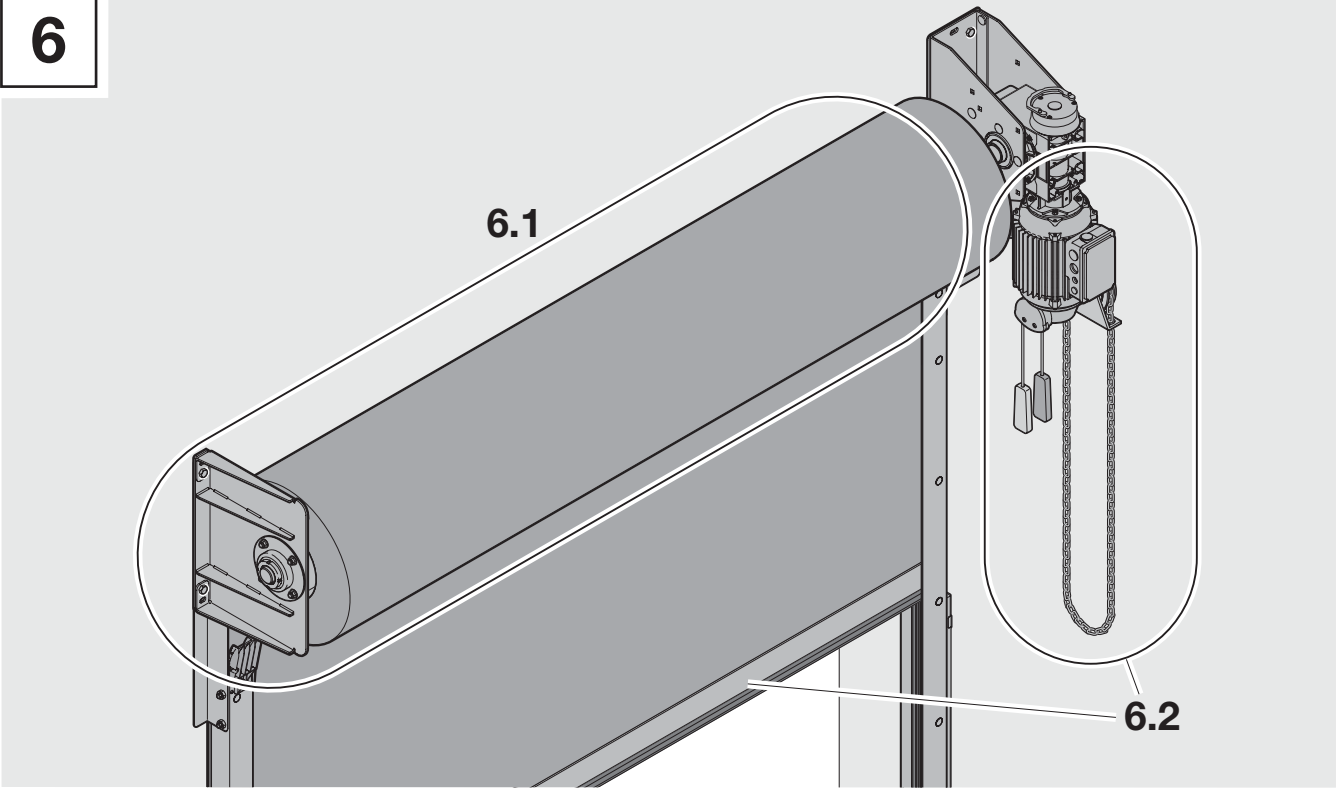

6.1

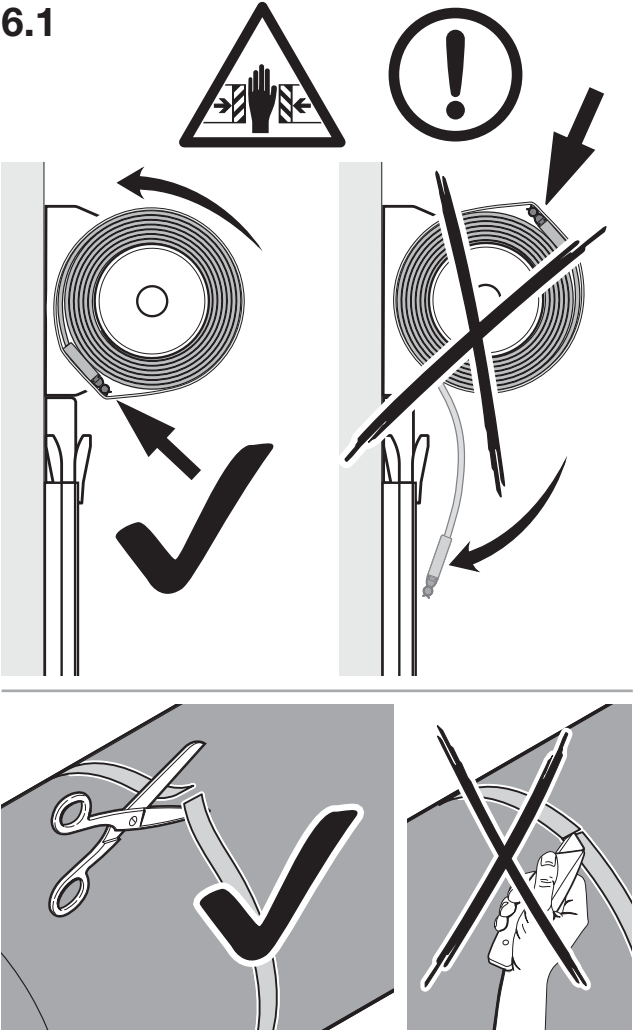

6.2

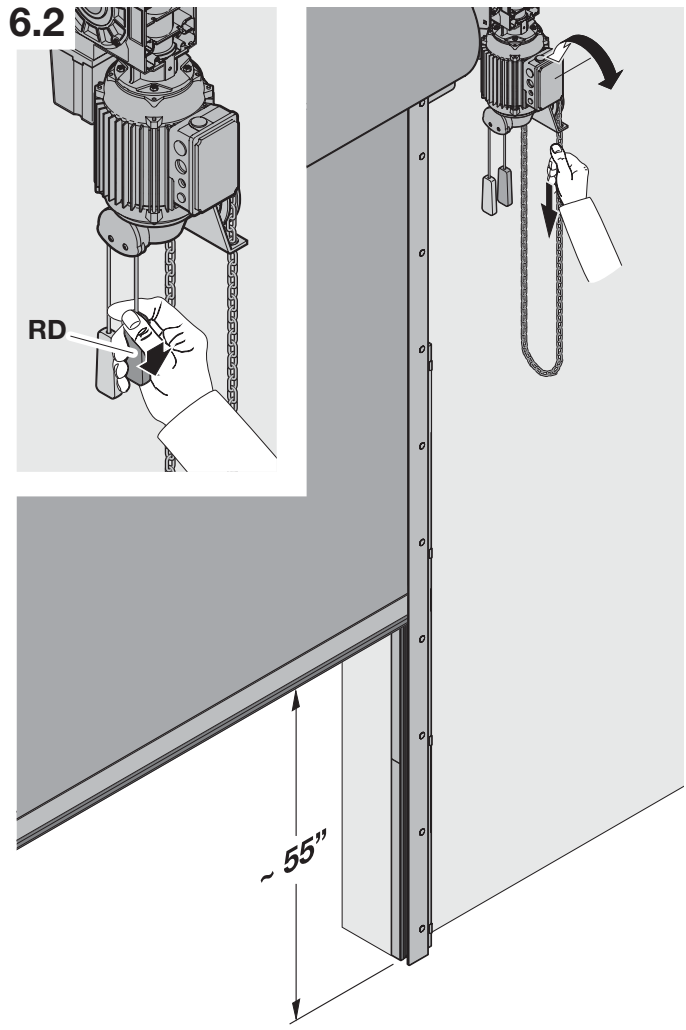

7

7.1

INSTALL SGR
(RECEIVER) TO
LH TRACK
(READ FROM LC
LABEL)

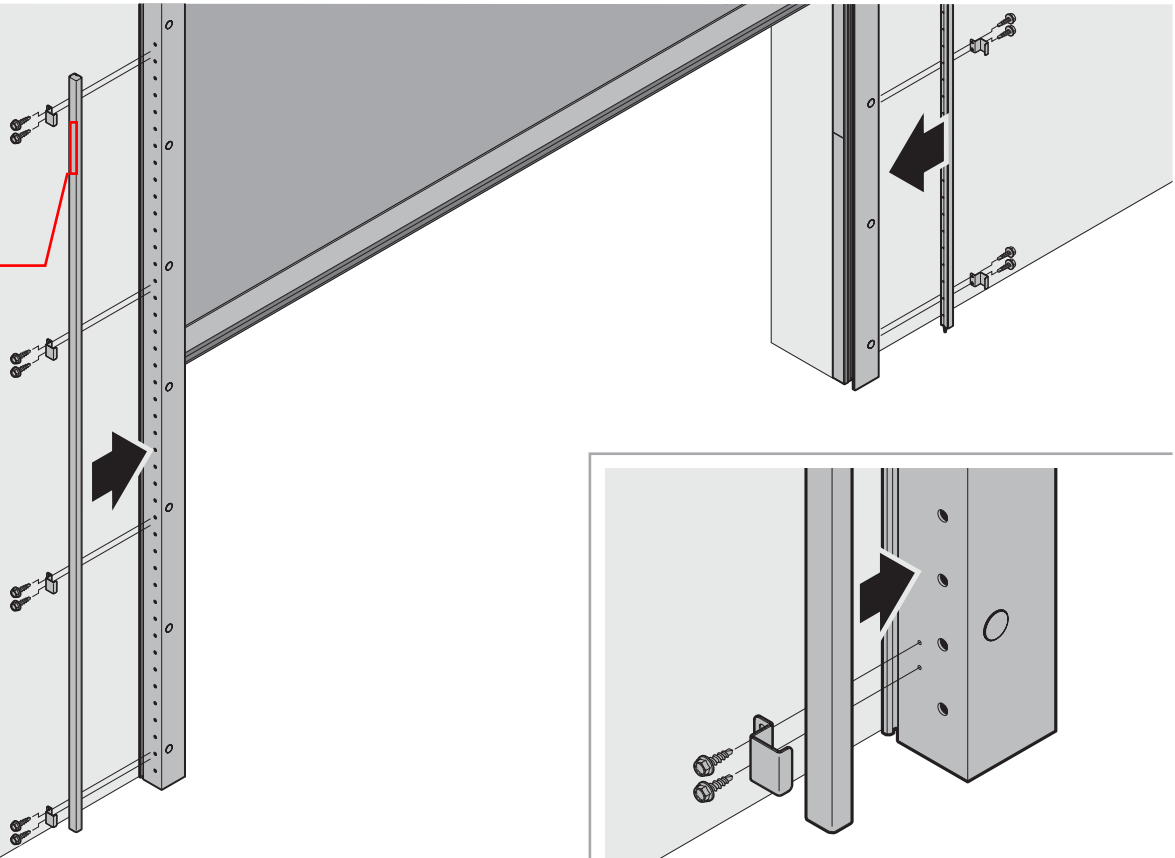

7.2

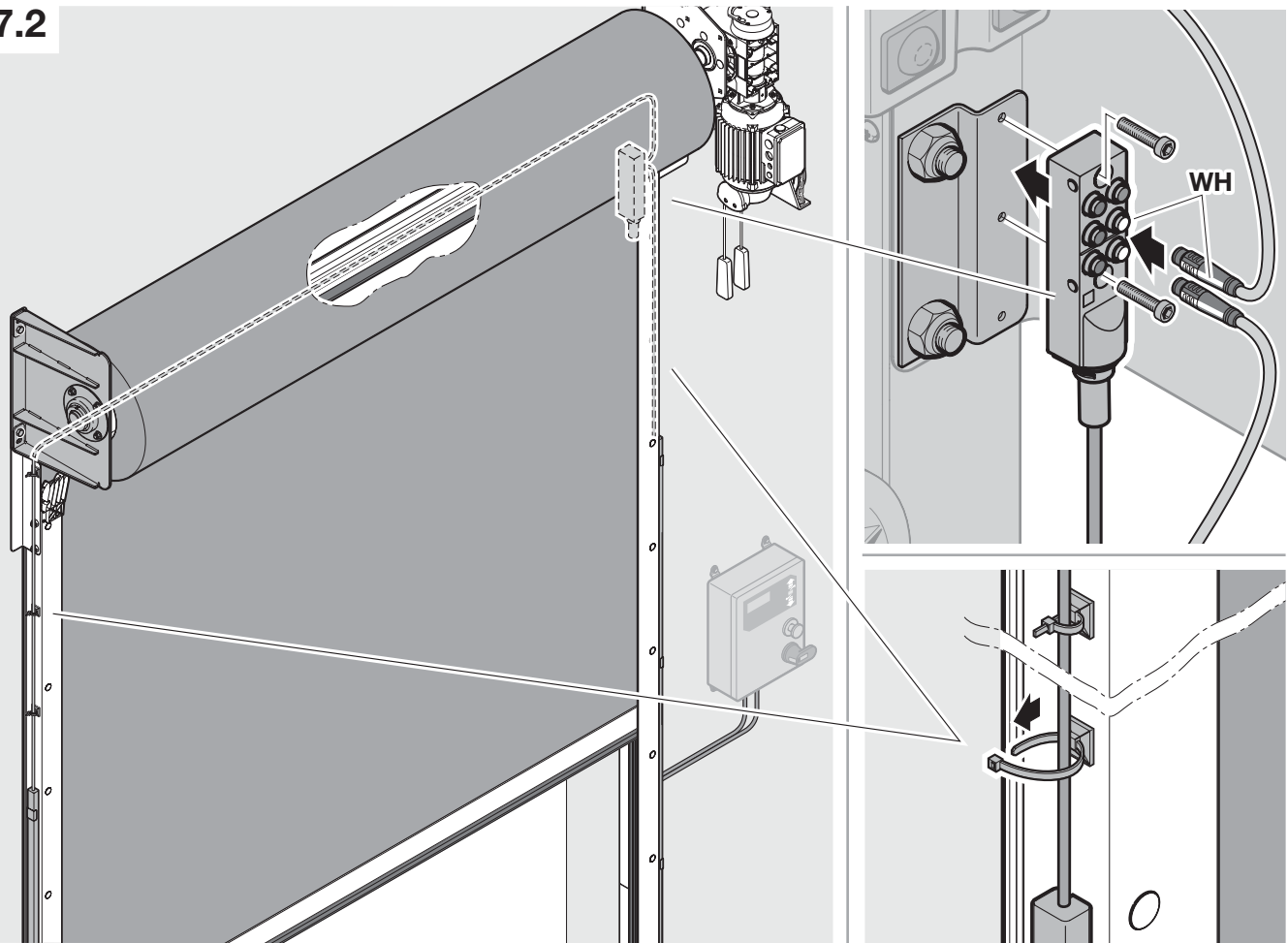

8

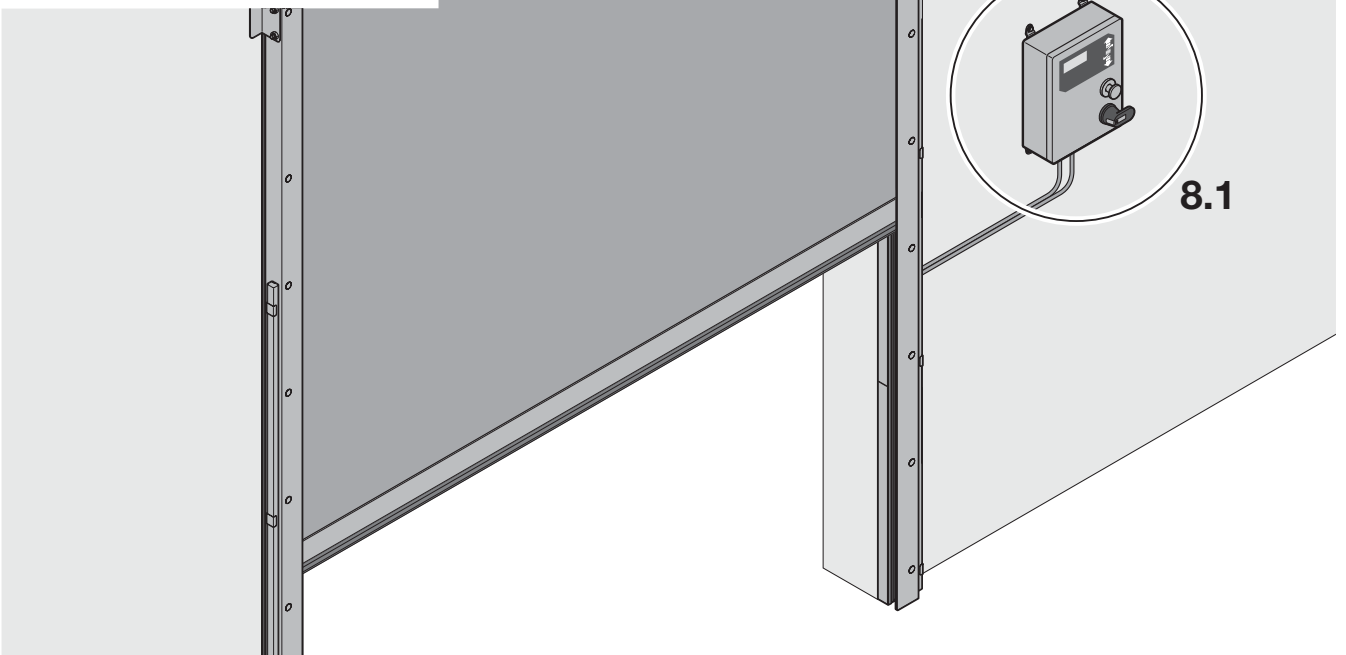

8.1

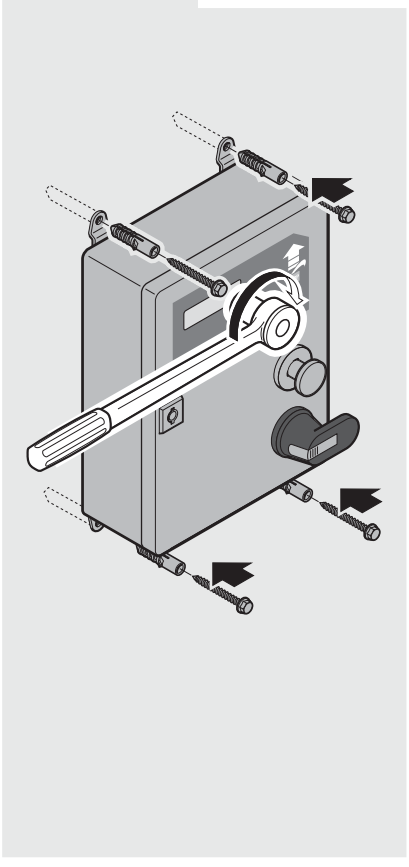
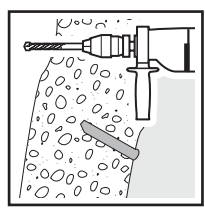

8.2

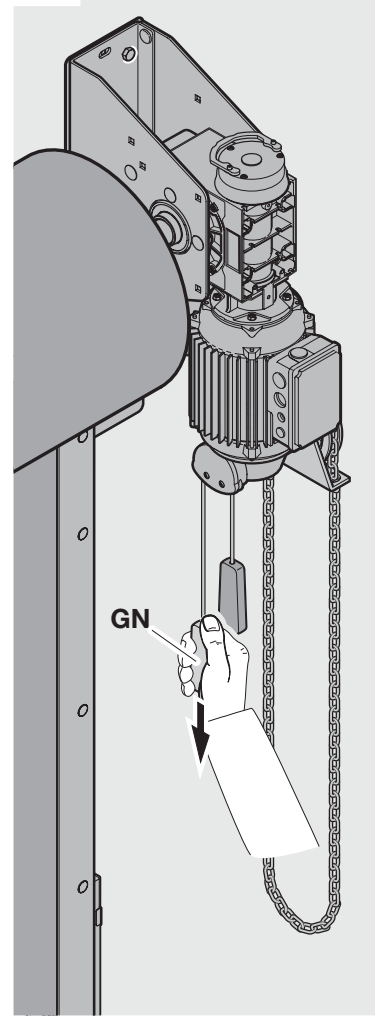

8.3

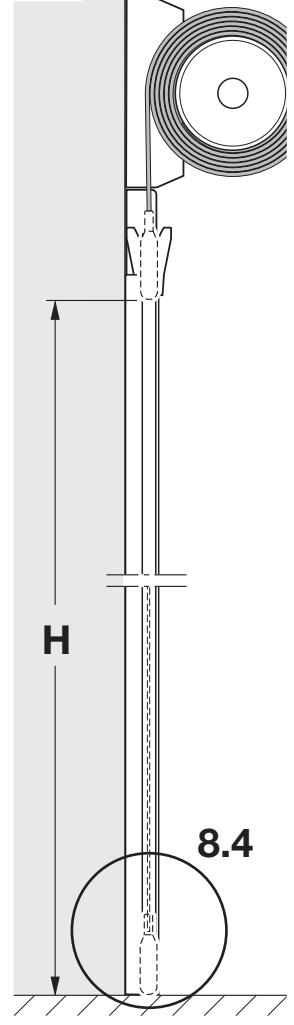

8.4

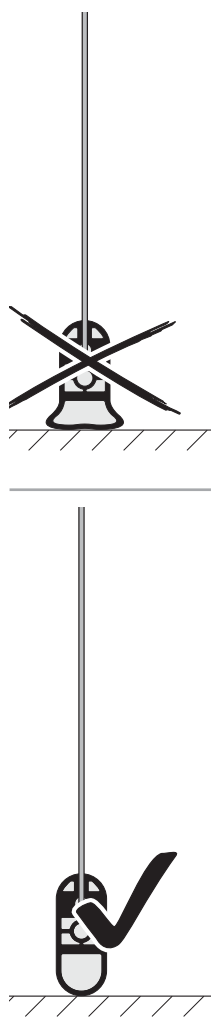

9

9.1
9.2
9.3
9.4

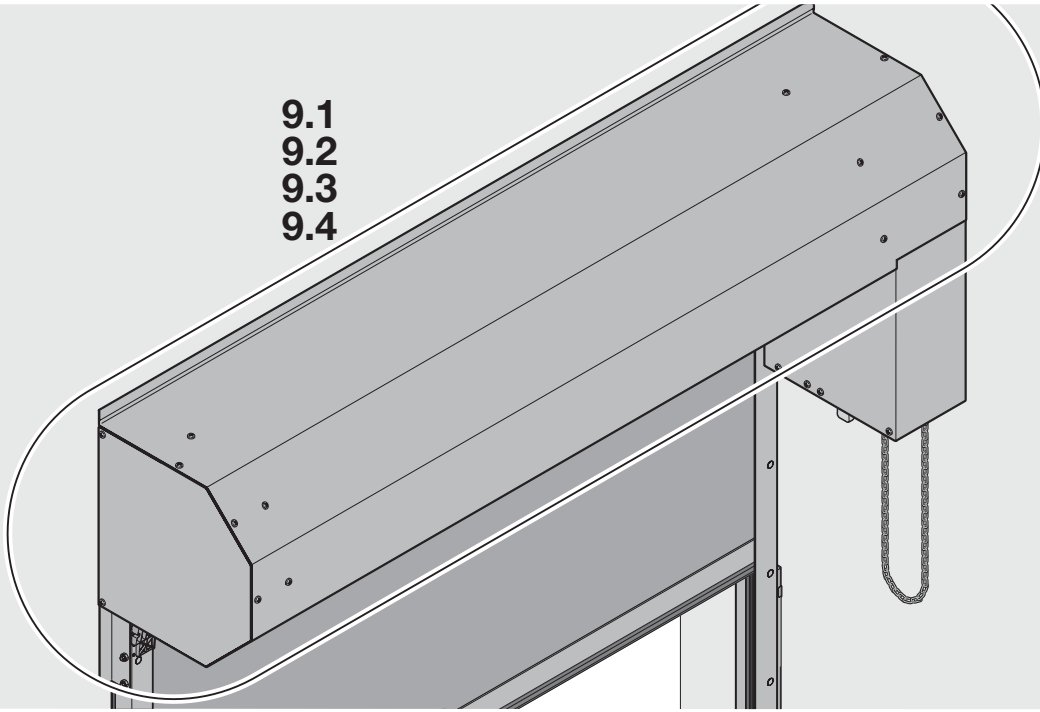

9.1

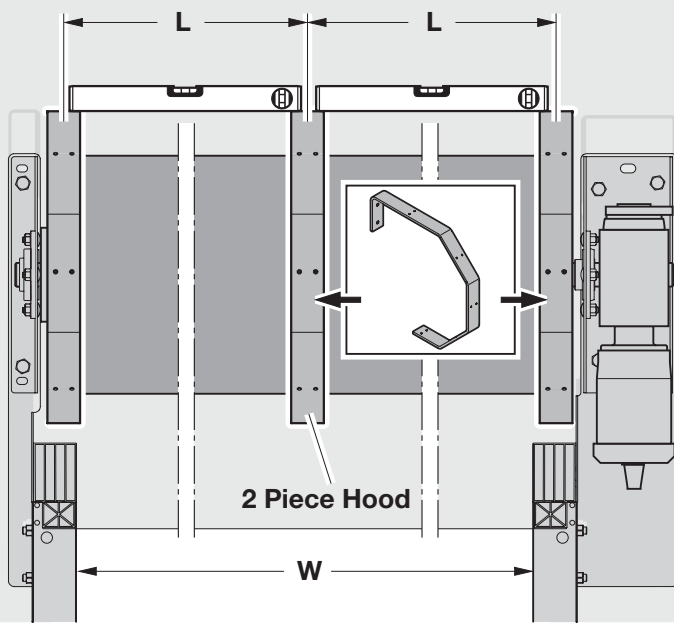

1 Piece Hood

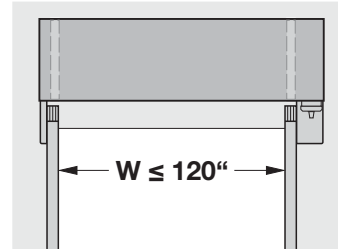

2 Piece Hood

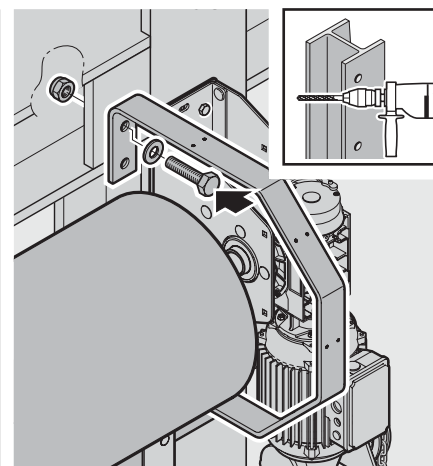
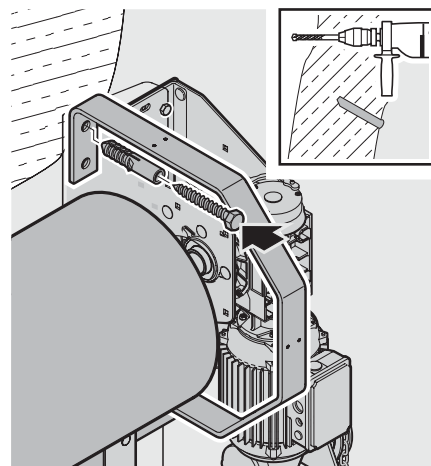
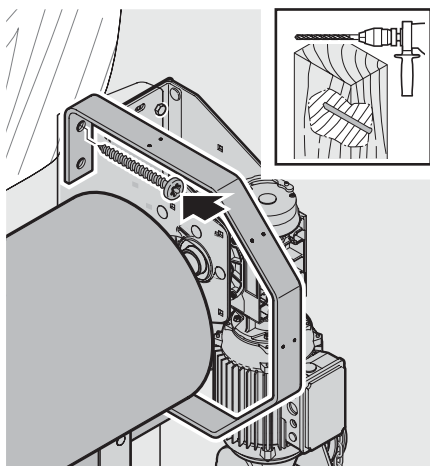
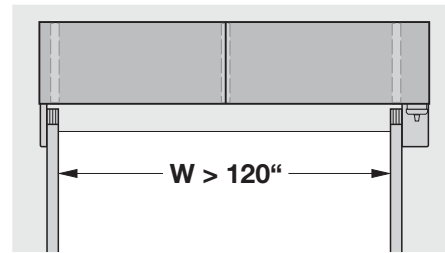

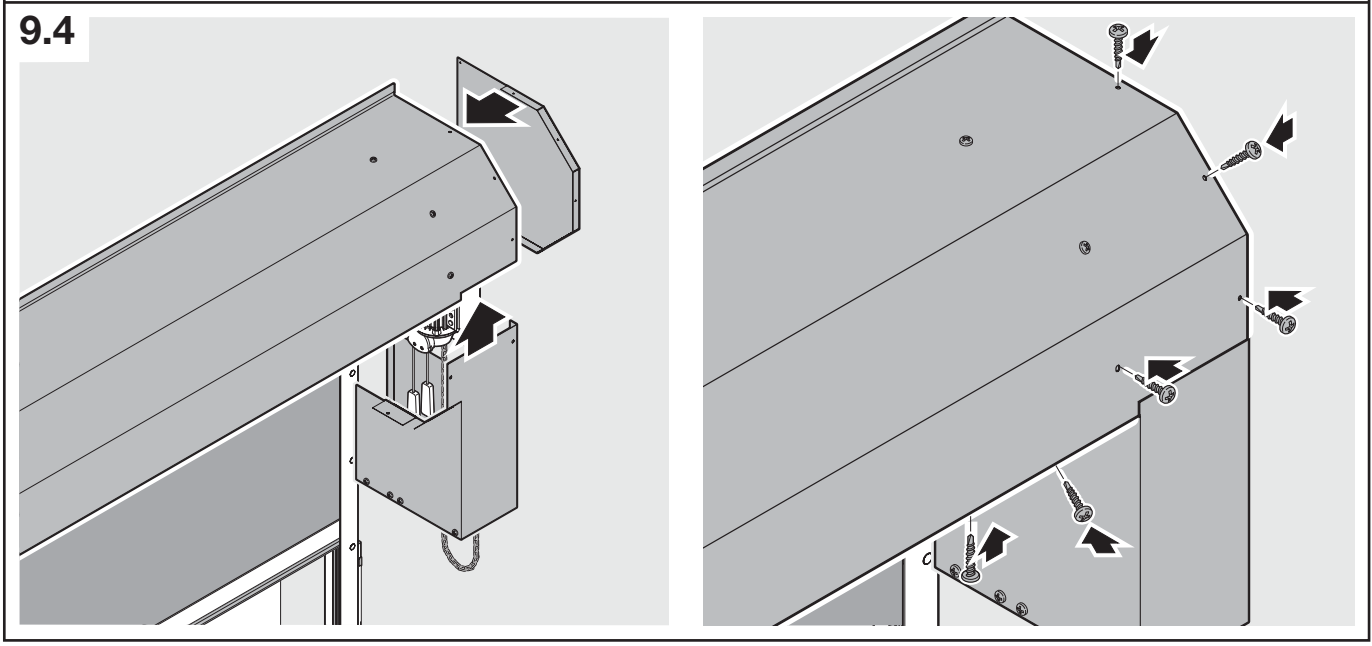
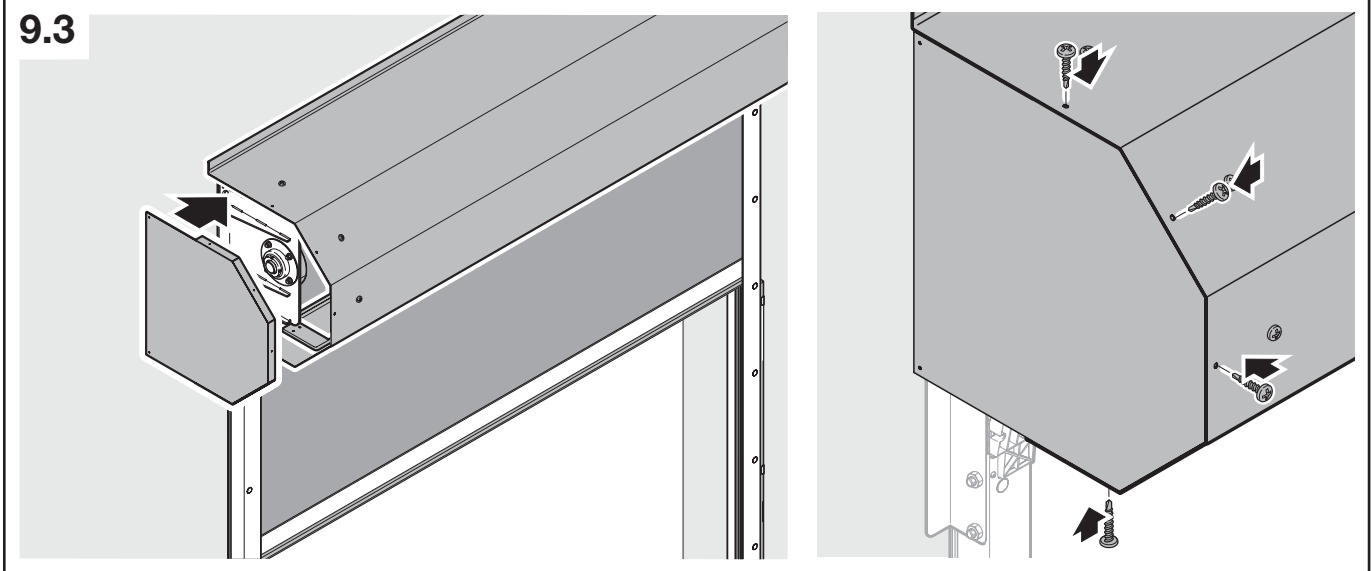
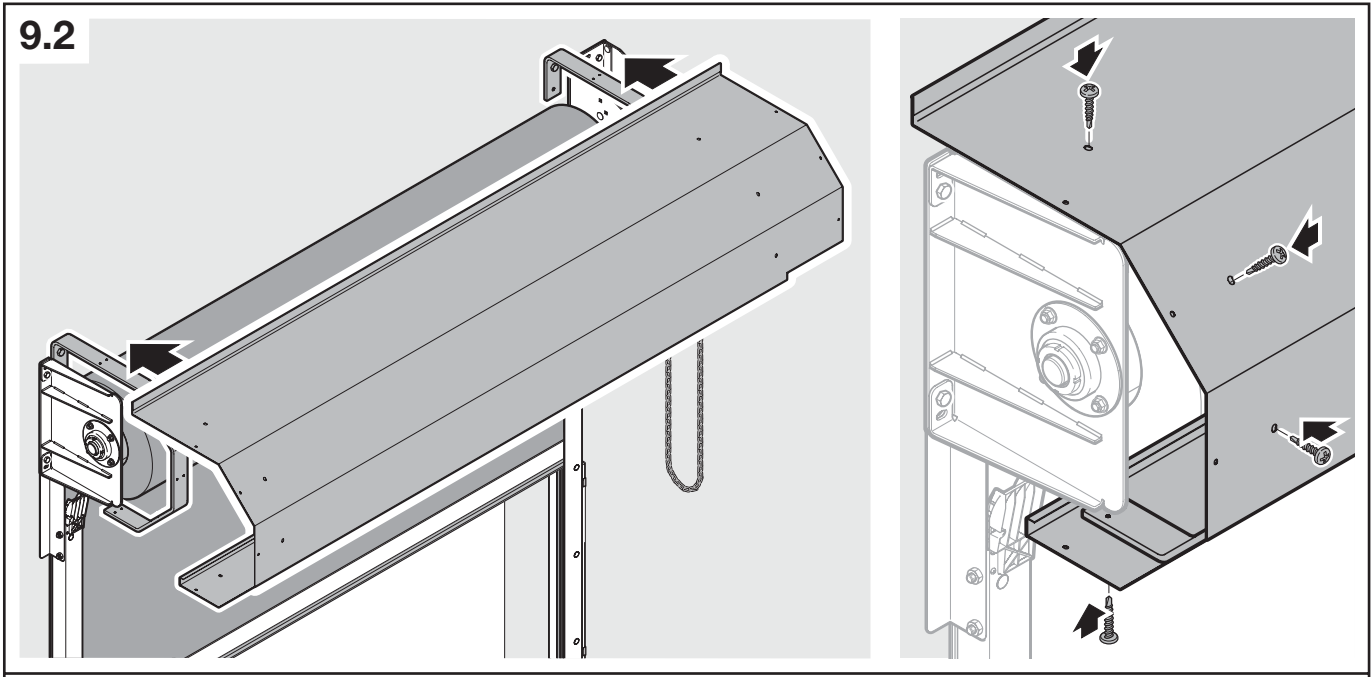

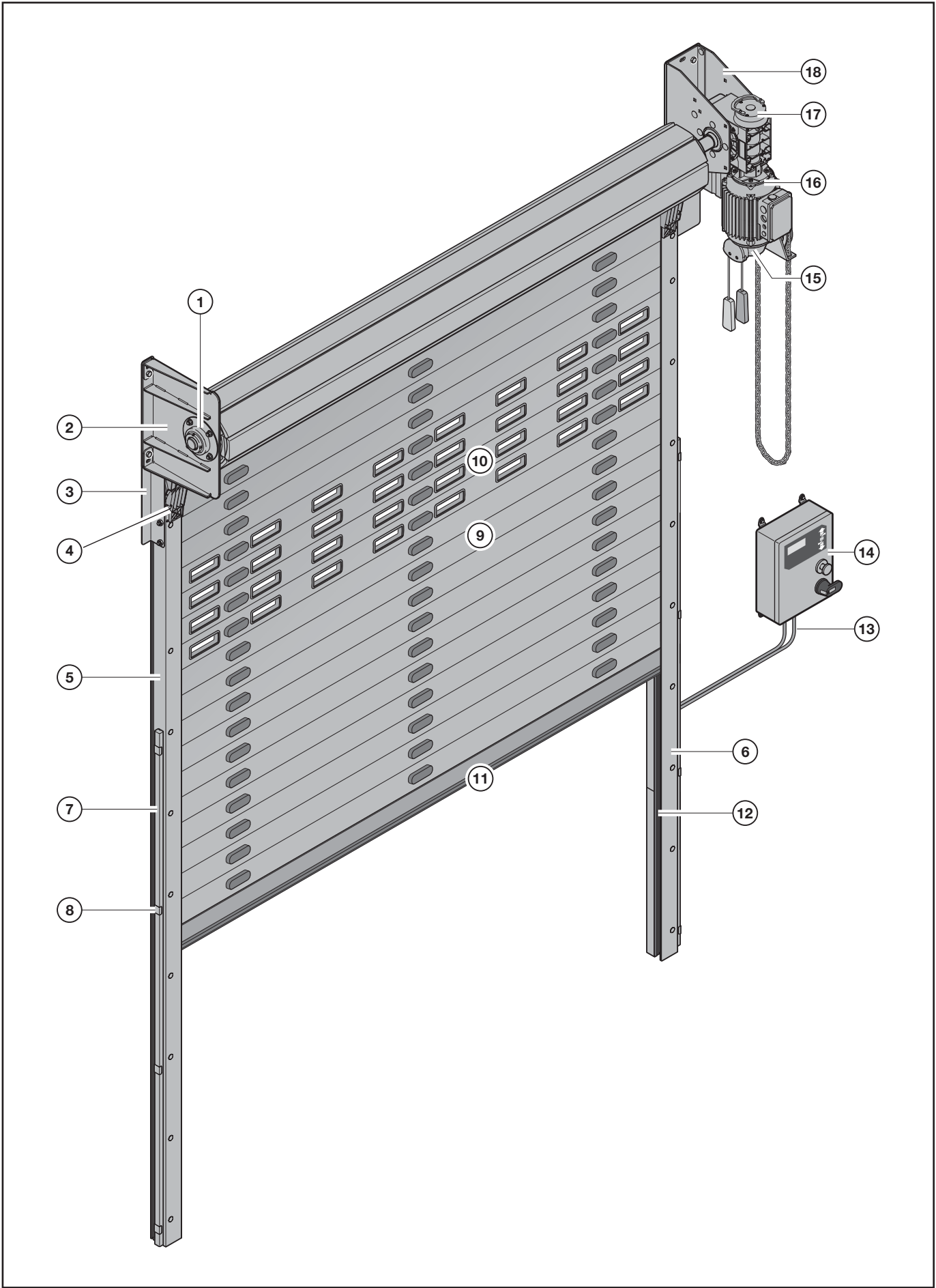

15 Spare Parts

| Item | Designation |
|------|--------------------------------|
| 1 | Bearing Set |
| 2 | Bearing Bracket Complete |
| 3 | Drilling Template Package |
| 4 | Track Funnel Set |
| 5 | Guide Complete Right |
| 6 | Guide Complete Left |
| 7 | Light Curtain Set |
| 8 | Light Curtain Clips Set |
| 9 | Solid Slat Complete |
| 10 | Window Slat Complete |
| 11 | Bottom Profile Complete |
| 12 | Side Guide Sliding Profile Set |
| 13 | Motor Cable |
| 14 | HFC1 TST-FU3E Hardwired |
| 15 | Chain Hoist Assembly |
| 16 | Operator F18 |
| 17 | Brake Kit - F18 Operator |
| 18 | Operator Bracket Complete |

Innovative Door Systems

HÖRMANN

Our promise to you

As one of the world's leading manufacturers of doors, we're committed to providing the best quality, value, and selection. Whether industrial or commercial, retail automotive, parking garages, transit, waste management,

fire stations or food processing, we have the door you're looking for. The Hörmann product line has a door for any application, from one manufacturer.



Hörmann, Burgettstown, PA



Hörmann, Barrie, Ontario, Canada

Connect with us!



Visit our website for more information!

Hörmann High Performance Doors
Starpointe Business Park • 117 Starpointe Boulevard
Burgettstown, PA 15021-9506
Phone: 800.365.3667 • 724.385.9150 • Fax: 724.385.9151
www.hormann.us • Email: info2@hormann.us



Hörmann TNR Doors
200 Fairview Road • Unit # 2
Barrie, Ontario L4N 8X8
Phone: 866.792.9968 • Fax: 705.735.9564
www.TNRdoors.com • Email: info@tnrdoors.com

We reserve the right to change specifications without notice. ©Hörmann Flexon LLC



USGBC
MEMBER

Environmental commitment has been part of our corporate culture for decades. From our manufacturing processes to the products we make.

In everything we do we strive to minimize energy and use of resources through efficient processes, long-lasting quality and innovative engineering.